

# SHOWERMATE

## Installation, Operation & Maintenance Instructions

Please leave this instruction booklet with the home owner as it contains important guarantee, maintenance and safety information



**Read this manual carefully before commencing installation.**  
This manual covers the following products:

**Showermate S2.6 bar Single**

Pt. No. 46429      Pt. No. 46429 EXP

**Showermate S1.8 bar Twin**

Pt. No. 46407      Pt No. 46407 EXP

**Showermate S2.6 bar Twin**

Pt. No. 46431      Pt No. 46431 EXP

**FOR POSITIVE HEAD APPLICATIONS ONLY**



## **PRODUCT DESCRIPTION**

Electric motor driven single or twin ended peripheral pumps complete with an automatic control system, consisting of flow switches and electronic controls.

## **APPLICATION**

Showermate pumps are designed for single or multiple (up to 4) outlet pressure boosting applications, within one bathroom, subject to correct specification and pump sizing in vented stored water systems. Inlet pressures to the pump and ambient temperatures must not exceed the values given in the technical specifications. Showermate Single pumps are not suitable for boosting a single side of a dual flow mixer valve or tap. Consult Stuart Turner for alternative pump.

## **STORAGE**

If this product is not to be installed immediately on receipt, ensure that it is stored in a dry, frost and vibration free location in its original packaging.

## **CONTENTS**

	Page
Checklist .....	.5
Important Facts – read before commencing installation .....	.6
Location .....	.7
Pump Connections .....	.11
Electrical Installation .....	.15
Commissioning .....	.18
Maintenance .....	.19
Technical Specification .....	.20
Trouble Shooting .....	.22
Guarantee .....	.23

## WARNINGS:



- This pump set must not be used for any other application without the written consent of Stuart Turner Limited and in particular, must not be connected directly to the mains water supply.
- This appliance can be used by children aged from 8 years and above and persons with reduced physical, sensory or mental capabilities or lack of experience and knowledge if they have been given supervision or instruction concerning use of the appliance in a safe way and understand the hazards involved.
- Children shall not play with the appliance.
- Cleaning and user maintenance shall not be made by children without supervision.
- The motor casing can become very hot under normal operating conditions. Care must be taken to ensure it cannot be touched during operation.



- The electrical installation must be carried out in accordance with the current national electrical regulations.
- The electrical installation must be installed by a qualified person.
- In the interests of electrical safety a 30 mA residual current device (R.C.D. not supplied) should be installed in the supply circuit. This may be part of a consumer unit or a separate unit.
- Maximum head (closed valve) S1.8 bar twin-18 metres, S2.6 bar twin-26 metres, S2.6 bar single-26 metres.
- Before starting work on the electrical supply ensure power supply is isolated.
- DO NOT allow the supply cord to contact hot surfaces, including the motor shell, pump body or pipework. The cord should be safely routed and secured by cable clips.



- **This appliance must be earthed via the supply cord, which must be correctly connected to the earth point located in the terminal box.**
- **The supply cord and internal wiring within the terminal box are routed and secured to ensure compliance with the electrical standard EN 60335-1. It is essential that prior to any disturbance of this internal wiring, all cable routing and securing details are carefully noted to ensure re-assembly to the same factory pattern is always maintained.**
- **If the supply cord is to be changed or is damaged, it must be replaced with a special cord assembly available from Stuart Turner or one of their approved repairers.**

**Please read installation details carefully as they are intended to ensure this product provides long, trouble free service. Failure to install the unit in accordance with the installation instructions will lead to invalidation of the warranty.**

# CHECKLIST

**IMPORTANT:** With the pump removed from its packaging check for any damage prior to installation. If any damage is found contact Stuart Turner Ltd within 24 hours of receipt.

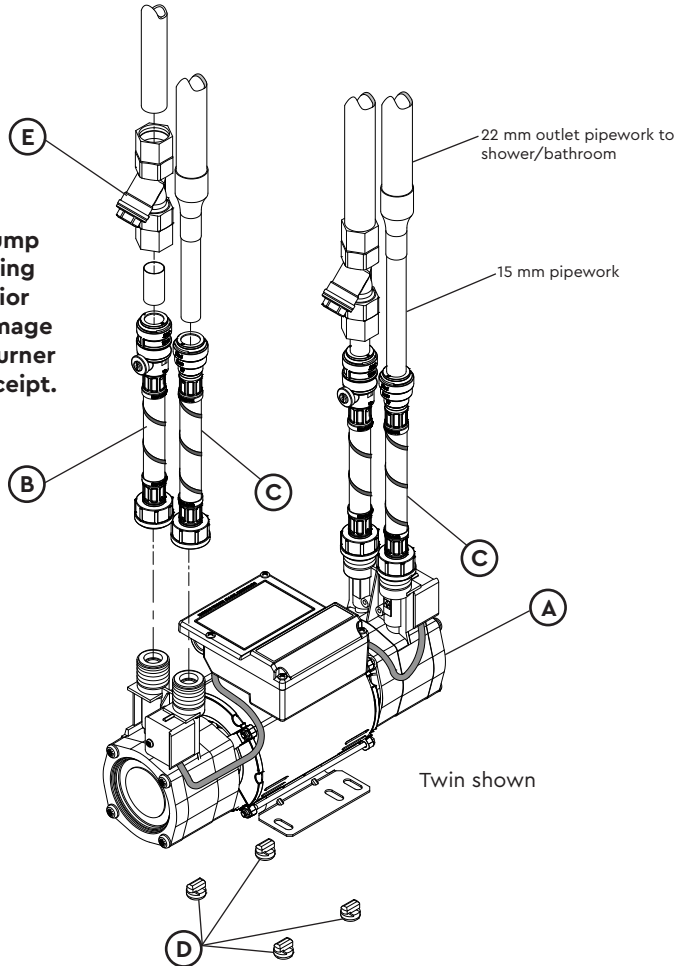

Fig. 1

Item	Description	Qty	Item	Description	Qty
(A)	Pump	1	(D)	Anti-vibration feet	4
(B)	ISO Hose & integral washer	2(1)	(E)	Inline strainers (not supplied)	2
(C)	Plain Hose & integral washer	2(1)			

Your product may vary slightly from the picture above.  
The quantities shown above are for twin pumps, (single pumps are shown in brackets).

## 1 IMPOTRANT FACTS: READ BEFORE COMMENCING PUMP INSTALLATION

### A Water storage capacity.

- 1.11 The hot and cold water storage capacity must be sufficient to meet the flow rates required by the pumped equipment and any other water using fittings and appliances, which may be operated simultaneously.
- 1.12 Ensure the pump is primed as described in the priming section before starting, damage to the shaft seal will result otherwise. See Section 5 – Commissioning.

### B Water temperature

The water entering the pump must be controlled as follows:

- 1.13 The maximum allowable water temperature is 65 °C.
- 1.14 The minimum allowable water temperature is 4 °C.
- 1.15 **DO NOT** fit a pump if the hot water is heated via a method whereby the water temperature cannot be controlled, such as solar or solid fuel you must consult the TechAssist team on +44 (0) 800 31 969 80.

### C Minimum Flow

- 1.16 For this pump to operate correctly there must be a minimum gravity flow of at least 0.8 l/min through all outlets to be pumped.

### D Pipework – General

- 1.17 **Secure pipework:** Ensure pipework to and from pump is independently supported & clipped to prevent forces being transferred to inlet and outlet branches of pump.
- 1.18 **Flux:** Solder joints must be completed and flux residues removed prior to pump installation (**flux damage will void any warranty**).
- 1.19 **Pipework design:** Care should be taken in the design of pipework runs to minimize the risk of air locks e.g. use drawn bends rather than 90° bends.



- 1.20 **DO NOT** introduce solder flux to flexible hoses, pumps or pump parts manufactured from plastic.

- 1.21 **DO NOT** allow contact with oil or cellulose based paints, paint thinners or strippers, acid based descalents or aggressive cleaning agents.



- 1.22 **DO NOT** install a non-return valve, or devices which contain non-return valves, in the suction (inlet) pipework to the pump. The pump must be free to vent to the supply tank at all times.

- 1.23 **DO NOT** bend the flexible hoses beyond 30°. They must be installed as straight as possible.

- 1.24 **DO NOT** connect this pump to the mains water supply.

### E Plumbing Installation Regulations

- 1.25 The plumbing installation must comply with the current water and building regulations.
- 1.26 The plumbing installation must be installed by a qualified person.

Cont ...

## 2 LOCATION – GENERAL



- 2.11 **Access:** For emergencies and maintenance the pump must be easily accessible.
- 2.12 **Protection:** The pump must be located in a dry position, frost free and protected from freezing, particularly when installed in a loft (not recommended).
- 2.13 **Ventilation:** Ensure an adequate air flow to cool the pump. Separate the pump from other appliances that generate heat. An 80 mm (3 ") air gap must be maintained around the pump.
- 2.14 **Safety:** The motor casing can become very hot under normal operating conditions. Care must be taken to ensure it cannot be touched during operation.
- 2.15 **Water retention:** Site the pump in a location where in the unlikely event of a water leak, any spillage is contained or routed to avoid electrics or areas sensitive to water damage.
- 2.16 **Static inlet pressure:** Before deciding where to locate the unit, check to ensure the static inlet head between pump and the bottom of the cold water tank (Figs. 2 & 3), is at least 0.5 metres and does not exceed the max inlet head of 13 metres.
- 2.17 **Ambient temperature:** The pump must be sited in a location where the maximum ambient temperature does not exceed 40 °C.
- 2.18 **Pipework:** For optimum performance pipework **MUST** be 22 mm. Pipework should only reduce to 15 mm when entering terminal fitting.
- 2.19 **Noise:** If supplied the anti-vibration mounting feet and flexible hoses can be used to reduce noise transmission, however care must be taken when mounting the pump that any noise is not amplified through loose panels or pipework. **Do not screw down the pump.**
- 2.20 **Direction of flow:** Ensure the water flow is in the direction of the arrow that is marked on the flow switch reed clamp (vertically upwards).
- 2.21 **Flexible hoses:** Only use the Stuart Turner hose set supplied with the pump.
- 2.22 **Isolating valves:** Separate system isolating valves (non restrictive) **must** be fitted to allow easy pump service.
- 2.23 **Inline strainer:** You **MUST** ensure the inlet pipework is fitted with an inline strainer.
- 2.24 **Preferred pump location:** The pump must, for optimum performance, be sited as close as possible to and never more than 4 metres from the HOT WATER cylinder. The pump should always be sited BELOW the HOT WATER take-off from the cylinder. The pump location is also dependent on limitations of the static inlet and outlet heads of the installation. For guidance on limitations and recommended location, consult the following relevant section for hot or cold water installation.

## 2 LOCATION – SINGLE PUMP

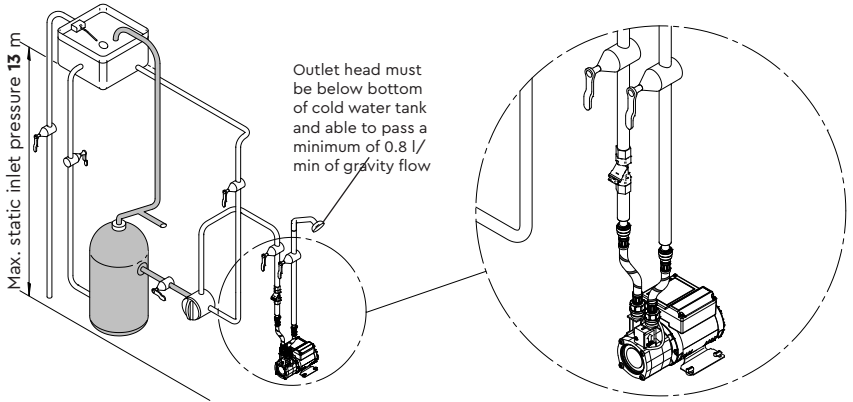

Single Pump System  
Fig. 2

## 2 LOCATION – TWIN PUMP

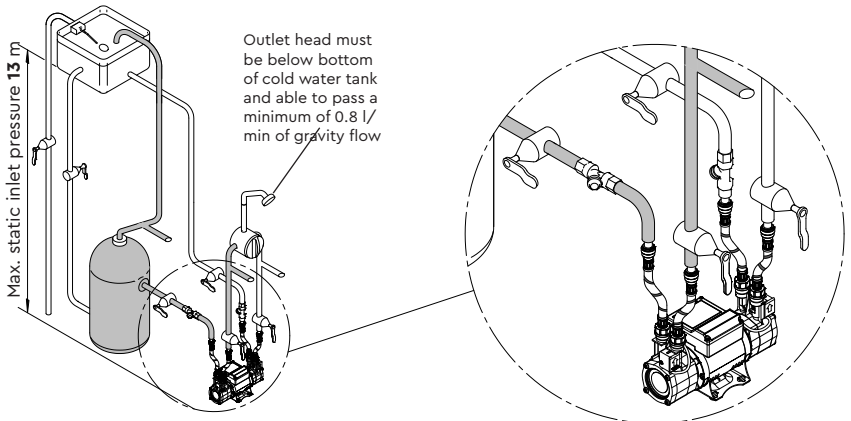

Twin Pump System  
Fig. 3

### Cold water connection:

2.25 **The cold water supply: Must be a DEDICATED AIR FREE** supply via a tank connector, and must be positioned at a slightly lower level (25 mm minimum) than the feed pipe to the hot water cylinder.

**Do not connect to the mains.**

Cont ...



**Hot water connection:**

- 2.26 **Hot water cylinder or storage tank:** When a hot water cylinder or storage tank is used, ensure the pipework size from the cold water storage to the hot water storage is of adequate size and a minimum of 22 mm.
- 2.27 **Hot water supply:** The pump **must be** supplied with a **dedicated feed** direct from the hot water cylinder or storage tank, ensuring an air free connection to the pump. We recommend the use of either the side entry Stuart flange (SE) Part No 27900 or a top entry flange see Fig. 4.
- 2.28 **Expansion pipe:** When the method of connection is to be made via the expansion pipe, the **BASE** of the cold water storage tank **MUST** be at least 1 metre above the connection/take off of the hot water storage cylinder feeding the pump.

Fig. 4

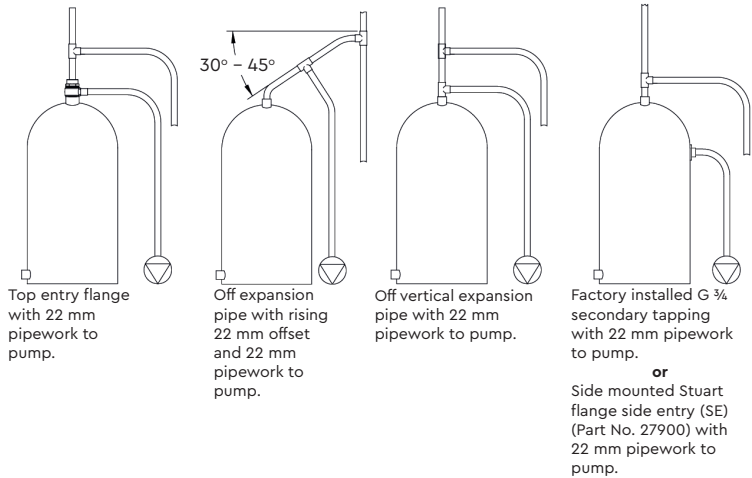

2.29 **Non-preferred pump location:** If it is necessary to position the Pump above the secondary tapping on the hot cylinder it is fed by, the risk of introducing air will be increased.

To avoid this risk one of the two following solutions must be adopted:  
 The use of a Top Entry cylinder flange.

The use of a Stuart Side Entry (SE) cylinder flange, which should have the addition of an inverted loop ("U" bend) of 350 mm minimum drop before rising to the pump, located as close as possible to the cylinder wall. This will ensure the pump receives an air free supply and the cylinder vents any air up the vent pipe and not the pump feed (Figs. 5 & 6).

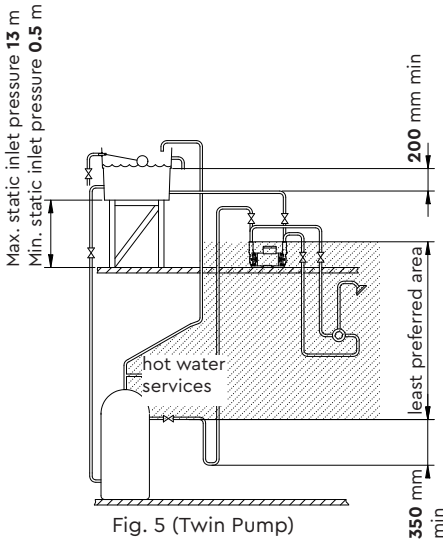

Fig. 5 (Twin Pump)

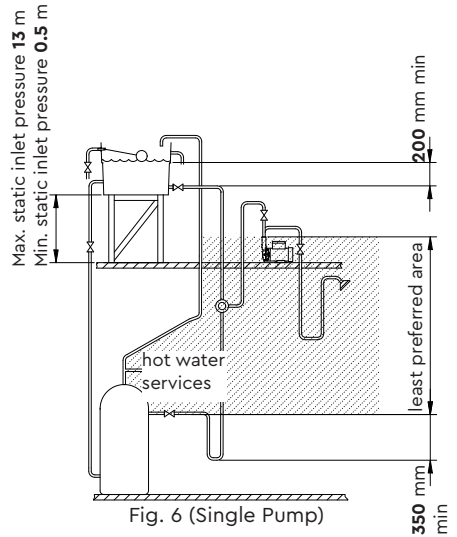

Fig. 6 (Single Pump)

### 3 PUMP CONNECTIONS



- Do not use stainless steel, chrome or nickel plated pipe with the flexible hose push-in plumbing connections.
- Do not introduce solder flux into the joint or surrounding area as connectors will be attacked and may fail.
- All solder joints should be completed and flux residues removed before final connection to push-in connections, on the flexible hose.
- Do not allow contact with oil or cellulose based paints, paint thinners or strippers, acid based descalents or aggressive cleaning agents.
- Never operate pump with inlet and/or outlet isolating valves in the closed position. Damage will occur!

3.11 **Pumps supplied with flexible inlet and outlet hoses:** The pump inlet and outlet ports are threaded G  $\frac{3}{4}$  male. These ports are provided with a flat sealing face suitable for use with an appropriately sized flat faced fitting and fibre or rubber washer. Ensure a water tight seal is achieved when the pump is both stationary and running.

- a) Hoses incorporating integral isolating valves should be applied to the inlet side of pump to satisfy servicing requirements.
- b) Standard hoses with no integral isolating valve should be applied to the outlet side of pump.
- c) Use correct tool for opening and closing integrated isolating valve to prevent damage.

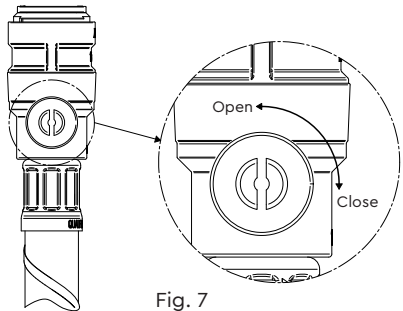

Fig. 7

Please note these valves are of quarter turn design, rotate clockwise to close and anti-clockwise to open. Failure to comply to these instructions could lead to valve damage.

- d) **WARNING – pump must not run with valve closed.**
- e) Flexible hoses with integral isolating valves **do not** replace system isolation valves which must be installed.

- 3.12 **Hose to pump:** The pump inlet and outlet ports have fittings which are specifically designed for connection to the G 3/4 female running nuts on the flexible hoses. The hose end running nut is fitted with a rubber sealing washer which is held captive within the nut assembly. Locate the hose into position and screw the nut fully onto the fitting by hand. Finally nip tight with pliers (4 to 5 Nm) for a water tight seal (**do not overtighten**).

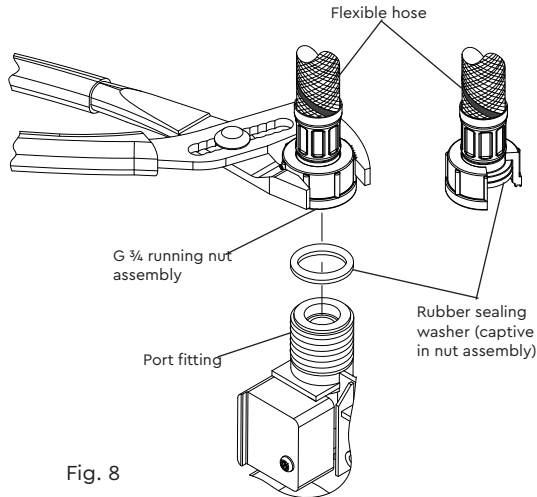

Fig. 8

### 3.13 **Hose to pipework:**

1. The hoses are fitted with plastic push-in connectors, which must only be connected with the following:
  - a) 15 mm diameter copper pipe to BS EN 1057 – R250 (half hard) – Table 3.
  - b) 15 mm plastic pipe to BS 7291 part 1 and part 2 (Table 1), or part 3 (Table 1) plus internal support sleeve\*.  
\* The internal bore of the plastic pipe must be supported against collapse with the pipe manufacturers recommended support sleeve (pipe insert).
  - c) Appropriate plumbing fitting that provides a leak tight connection.

Ensure the pipe is free from all score marks and deformities in the area of the insertion depth (Fig. 9) and cut the pipe square, removing all burrs and sharp edges to prevent damage to the sealing 'O'-ring.

2. Prior to inserting pipe into fitting, mark the insert depth on the wall of the pipe with a soft pencil at a distance of 31 mm from the end to be inserted (Fig. 9).

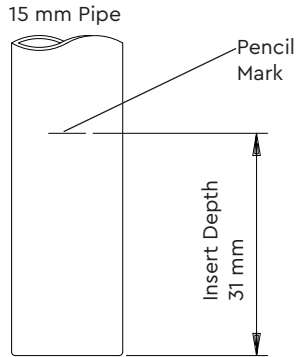

Fig. 9

3. Check in the mouth of the fitting that the 'O'-ring, nylon washer and collet are in position as shown in Fig. 10.

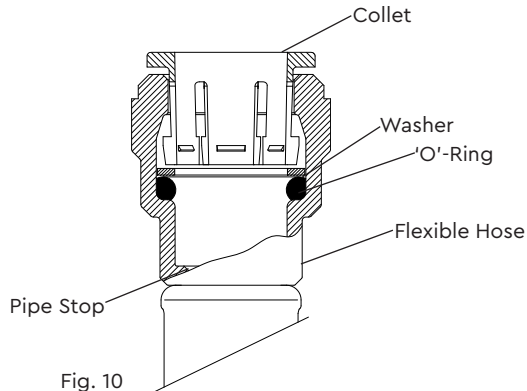

Fig. 10

4. Push the pipe firmly into the fitting, until pencil mark is level with the top of the collet and the pipe stop resistance is felt. Pull on the pipe to check it is secure and correctly fitted
5. To release the joint, push pipe firmly into the fitting, hold the collet down and gently remove pipe. If the system has been filled with water care should be taken to isolate the pump and towels used to absorb spilled water.

### 3.14 Typical Low Level Installation:

In certain installations it may be necessary to install a 90° bend on the inlet or outlet connections of the pump before the flexible hose to accommodate a low level installation.

Below are some preferred connection options. All connections seal on the pump body using a fibre or rubber sealing washer. Tap connector fittings should be used which must be of an appropriate pressure and temperature rating.

It is essential when using any of the fittings shown below, that a correct water tight seal is obtained between the pump body and selected fitting and also the flexible hose and selected fitting. If in doubt contact the fitting manufacturer and confirm compatibility with the connection to be sealed.

Carefully check connections and pipework for leaks whilst pump running and stationary before leaving the installation unattended.

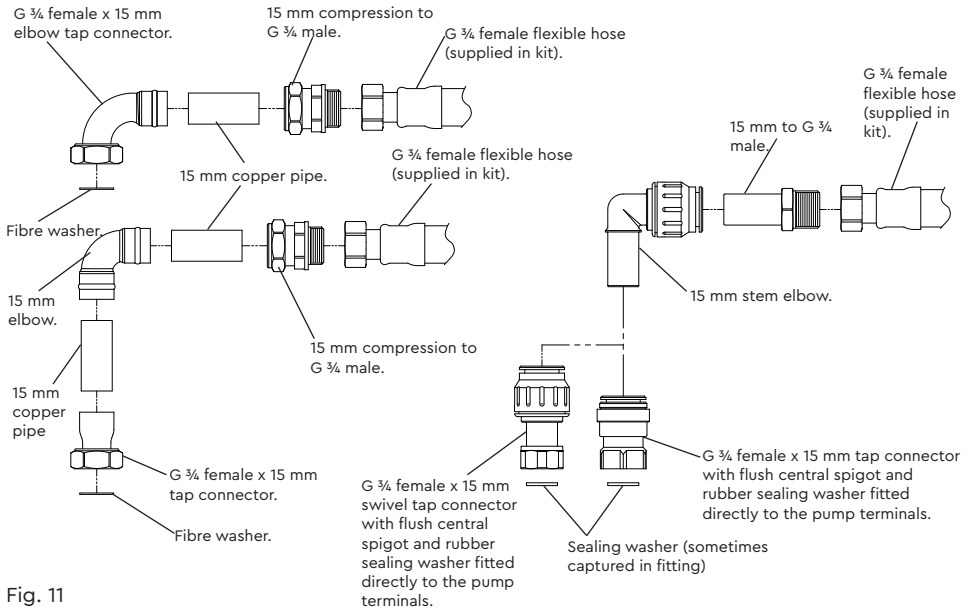

Fig. 11

**If you have any concern either about using push-in fittings or should the joint leak on final test, isolate the water supplies and contact TechAssist on +44 (0) 800 31 969 80.**

## 4 ELECTRICAL INSTALLATION



- 4.11 **Regulations:** The electrical installation must be carried out in accordance with the current national electrical regulations and installed by a qualified person.
- 4.12 **Safety:** In the interests of electrical safety a 30 mA residual current device (**R.C.D. not supplied**) should be installed in the supply circuit. This may be part of a consumer unit or a separate unit.
- 4.13 Before starting work on the electrical supply ensure power supply is isolated.
- 4.14 **DO NOT** allow the supply cord to contact hot surfaces, including the motor shell, pump body or pipework. The cord should be safely routed and secured by cable clips.
- 4.15 **Adjacent pipes:** Adjacent suction and delivery pipes should be fitted with earthing clamps in accordance with current regulations (Fig. 12).

Diagram of  
earth  
continuity  
connections

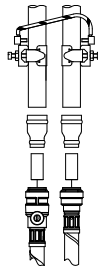

Fig. 12

- 4.16 **Earthing:** This appliance must be earthed via the supply cord, which must be correctly connected to the earth point located in the terminal box.
- 4.17 **Pipework:** Copper or metallic pipework must have supplementary earth bonding where the continuity has been broken by flexible hoses or plastic components.
- 4.18 **Additional earthing:** Certain installations may require additional earthing arrangements such as equipotential bonding. Reference should be made to the relevant regulations concerning this subject to ensure compliance.
- 4.19 **Connections:** The pump must be permanently connected to the fixed wiring of the mains supply using the factory fitted supply cord, via a double pole switched fused spur off the ring main and **NOT** connected to the boiler or the immersion heater circuits.

#### 4.20 Wiring Of Connection Unit:



**WARNING: This appliance must be earthed.**

The wires in the mains lead (supply cord) are coloured in accordance with the following code:

- Green and Yellow: Earth
- Blue: Neutral
- Brown: Live

As the colours of the wires in the mains lead of this appliance may not correspond with the coloured markings identifying the terminals in your connection unit proceed as follows:

- The wire which is coloured green and yellow must be connected to the terminal in the connection unit which is marked with the letter E or by the earth symbol:  $\oplus$  or coloured green or green and yellow.
- The wire which is coloured blue must be connected to the terminal which is marked with the letter N or coloured black.
- The wire which is coloured brown must be connected to the terminal which is marked with the letter L or coloured red.

#### 4.21 Wiring Diagrams:

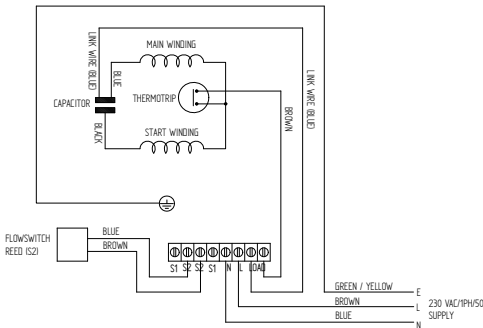

Single Pumps  
Fig. 13

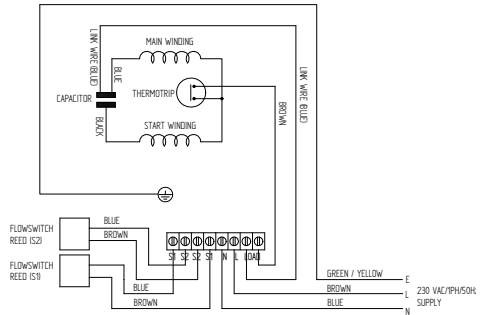

Twin Pumps  
Fig. 14

4.22 **Fuses:** The following fuse size should be used with the appropriate pump.

Model	Fuse Size (AMPS)
All Models	5



#### 4.23 Supply Cord Replacement:



The supply cord and internal wiring within the terminal box are routed and secured to ensure compliance with the electrical standard EN 60335-1. It is essential that prior to any disturbance of this internal wiring, all cable routing and securing details are carefully noted to ensure re-assembly to the same factory pattern is always maintained.

If the supply cord is to be changed or is damaged, it must be replaced with a special cord assembly available from Stuart Turner or one of their approved repairers.

On disassembly note the cord retention and routing system. Re-assemble to the same pattern.

For information on cable connection consult the wiring diagram and cable gland fitting instructions.

#### 4.24 Cable Gland Fitting Instructions:

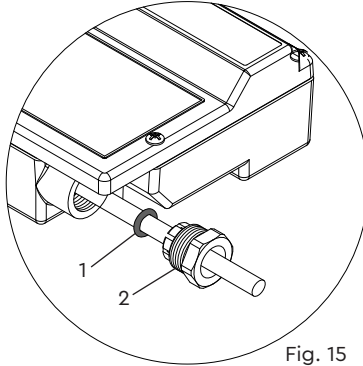

Fig. 15

To enable correct assembly of the cable gland the 'O'-ring (Fig. 15 item 1) must be placed over the cable before the clamping insert (Fig. 15 item 2) can be tightened.

Note: Cable diameter range:- 6.5 mm to 9.5 mm.

#### 4.25 Supply Cord Extension:

The pumps are fitted with a supply cord to the following specification:-

All models. . . . .HO5VV-F3 G 0.75 mm<sup>2</sup> – 6 Amp rated cable.

If the supply cord is to be extended, a cord of the same specification should be used. Any connections or junction boxes used should be specifically suited for the application and installed in accordance with the manufacturers instructions.

## 5 COMMISSIONING



5.11 **System Flushing:** This pump incorporates push-in connectors and plastic components that must not come into contact with solder flux, acid-based descalents or aggressive cleaning agents. The pipework system should be flushed out prior to the pump being connected to ensure any contaminants/chemical residues and foreign bodies are removed from elsewhere in the system.

5.12 **Water Supply:** Always ensure that water storage capacity is adequate to meet the demand. Ensure the pump chamber is full of water before starting the pump. Failure to do this could result in seal damage. To ensure dry running does not occur the pump must be primed as described in priming section below. **Do not run pump dry.**

5.13 **Priming:**



**Never operate pump with inlet and/or outlet isolating valves in the closed position. Damage will occur!**

The pump must be primed (filled with water) before starting. Turn on water supply from the system service valves, prime and vent the pump by opening the pump inlet and outlet isolating valves to allow pump to fill and vent. In the case of twin pumps, both pump chambers must be independently primed.

5.14 **Starting:**

- a) Ensure the outlet is closed, turn power supply 'on'.
- b) Open and close the outlet in turn associated with the pump, allowing water to flow from each outlet until all air is purged. As each outlet is opened and closed, the pump will start and stop respectively.
- c) The tap or control valve within the system when opened and closed will now turn the pump on/off. If this is confirmed to be the case, the system is now operating correctly.
- d) Carefully check pump and pipework for leaks whilst pump running and stationary before leaving the installation unattended.

5.15 **For Further Technical Support:** Phone the Stuart Turner TechAssist team on +44 (0) 800 31 969 80. Our staff are trained to help and advise you over the phone.

## 6 MAINTENANCE



6.11 Turn off water supplies to the pump and release pressure by opening water outlets before attempting maintenance.

6.12 **Water scale:** As water is heated scale deposits are released in areas of hard water, scale can cause the mechanical seal to stick if left without use for long periods. The pump must be run for at least 5 minutes every four weeks to "exercise" all working parts. Run on cool water. See Section 7 – Technical Specification for note on water temperature. This particularly applies to guest bathrooms used infrequently.

6.13 **Cleaners, Disinfectants and Descalents:**



Acid based descalents and aggressive cleaning agents must not come into contact with the pump. The pump must be removed from the system prior to the use of these products. The system should be flushed to remove all chemicals before the pump is re-connected. If in any doubt as to the suitability of the chemical solutions, please contact our TechAssist helpline on +44 (0) 800 31 969 80.

6.14 No other routine maintenance is required.

## 7 TECHNICAL SPECIFICATION

Pump Model		S1.8 bar Twin 46407	S2.6 bar Twin 46431	S2.6 bar Single 46429
General	Guarantee	3 years		
	WRAS approval	1709101		
	Approvals	WRAS, CE		
Features	Pump type	Peripheral		
	Mechanical seal	EPDM / PTFE / Al. Oxide		
	Anti-vibration feet	✓	✓	✓
	Flexible hoses	4	4	2
	Dry run protection	✓	✓	✓
	Noise (dB(A))	55	56	52
Materials	Pump body	Plastic		
	Impeller	Plastic		
Performance	Maximum head (closed valve)	1.8 bar (18 metres)	2.6 bar (26 metres)	
	Performance @ 9 l/min	1.5 bar	1.9 bar	1.3 bar
	Performance @ 18 l/min	0.8 bar	1.3 bar	0 bar
	Maximum flow	33 l/min	36 l/min	18 l/min
	Maximum static inlet pressure	13 metres		
	Maximum working pressure*	380 kPa (3.8 bar)		
	Maximum ambient air temperature	40 °C		
	Min / Max water temperature**	Min 4 °C / Max 65 °C		
	Flow switch sensitivity (approx)	0.8 l/min		
Connections	Pump connections	G ¾ male		
Flexible hoses	Connections (UK model)	G ¾ female x 15 mm push-in x 200 mm long, isolating valves on inlet hoses		
Motor	Type	Induction, auto-reset thermal trip		
	Duty rating	Continuous (S1) @ 9 l/min and above ***		Continuous (S1) @ 9 l/min and above
Electrical	Power supply / phase / frequency	230 V a.c. / 1 / 50 Hz		
	Current (full load)	1.8 Amps	2.2 Amps	1.1 Amps
	Power consumption	405 Watts	505 Watts	245 Watts
	Fuse rating	5 Amps		
	Power cable (pre-wired)	1.5 metres		
Physical	Enclosure protection	IP22		IP22
	Length	304 mm	319 mm	223 mm
	Width	132 mm		
	Height (excluding hoses)	179 mm		
	Weight (including fittings)	4.6 Kg	5.4 Kg	4.0 Kg

Stuart Turner reserve the right to amend the specification in line with its policy of continuous development of its products.

**Note:** For information on other voltages/frequencies which are not shown, consult TechAssist on +44 (0) 800 31 969 80.

**\*Note:** The maximum pressure that can be applied to the pump under any installation conditions.

Cont ...

\*\*Note: A stored water temperature of 60°C is considered sufficient to meet all normal requirements and will minimize deposition of scale in hard water areas.

\*\*\* Note: Both heads pumping 4.5 l/min and above.



**Maximum permissible water temperature 65°C.**

7.11 **Noise:** The equivalent continuous A-weighted sound pressure level at a distance of 1 metre from the pump does not exceed 70 dB(A).

## 8 TROUBLE SHOOTING GUIDE

Symptoms	Probable Cause	Recommended Action
Pump will not start.	<p>Insufficient gravity flow.</p> <p>Electrical.</p> <p>Pump jammed.</p> <p>Integral motor thermotrip activated.</p>	<p>Check flow rate minimum of 0.8 l/min required on full hot and cold.</p> <p>Check power supply. Check fuse (see fuse section). Check circuit breaker is set. Check wiring connections.</p> <p>If motor 'Buzzes' switch off power and contact Stuart Turner.</p> <p>Wait for thermotrip to auto-reset and check that duty point and run time is within specification (see technical specification).</p>
Reduced/intermittent flow.	<p>Incorrect or no anti-aeration flange fitted.</p> <p>Incorrect pipe sizes.</p> <p>Blocked inlet filters.</p> <p>Hot water temperature set to high.</p> <p>Blocked shower head spray plate.</p>	<p>Check that the installation complies with installation instructions.</p> <p>Check for correct pipe sizing, see Page 7 – Section 2.18.</p> <p>Clean inlet filters.</p> <p>Reduce cylinder stat setting to 65 °C max.</p> <p>Clean in accordance with manufacturers instructions.</p>
No hot water.	<p>Air locked water feed.</p> <p>Heating source not operating.</p> <p>All hot water has been used.</p> <p>Faulty thermostatic mixer valve.</p>	<p>Vent hot water pump of air. Check cold feed to hot water cylinder. Check water level in cold water tank and that all stopcocks and isolating valves are open.</p> <p>Check boiler is switched 'on'. Check cylinder thermostat. Check immersion heater. Check cylinder contains hot water.</p> <p>Check tank volume is adequate.</p> <p>Consult makers instructions.</p>
Pump runs on with outlets closed.	<p>Jammed flow switch.</p> <p>Damaged reed switch or P.C.B.</p> <p>Leak in system.</p>	<p>Remove outlet hoses and check that flow switch sits in lowest position. Check float for free movement.</p> <p>If pump continues to run, this indicates a closed circuit in either the flow switch reed or P.C.B. in the terminal box. Contact Stuart Turner.</p> <p>Check tap washers, w/c valve washers, pipe joints.</p>
Pump starts with all outlets closed.	<p>Air in system.</p>	<p>Bleed through system without pump running until hot and cold services run with no air.</p>
Flexible hose leaks	<p>Not fitted correctly.</p> <p>Damaged 'O'-rings.</p>	<p>Check that the hose is pushed firmly onto the pump inlet/outlet connections and pipework.</p> <p>Check copper pipe ends are cleanly cut and deburred.</p>

**8.11 Environment Protection:** Your appliance contains valuable materials which can be recovered or recycled.

At the end of the products' useful life, please leave it at an appropriate local civic waste collection point.

Cont ...

## 9 THE SHOWERMATE GUARANTEE

Congratulations on purchasing a Stuart Turner pump.

We are confident this pump will provide many years of trouble free service as all our products are manufactured to the very highest standard.

All Showermate Pumps are guaranteed to be free from defects in materials or workmanship for 3 years from the date of purchase.

Within the guarantee period we will repair, free of charge, any defects in the pump resulting from faults in material or workmanship, repairing or exchanging the whole unit as we may reasonably decide.

Not covered by this guarantee: Damage arising from incorrect installation, improper use, unauthorised repair, normal wear and tear and defects which have a negligible effect on the value or operation of the pump.

Reasonable evidence must be supplied that the product has been purchased within the guarantee term prior to the date of claim (such as proof of purchase or the pump serial number).

This guarantee is in addition to your statutory rights as a consumer. If you are in any doubt as to these rights, please contact your local Trading Standards Department.

In the event of a claim please telephone '**TechAssist**' or return the pump with the accessories removed e.g pipes etc. If you have any doubt about removing a pump, please consult a professional.

**+44 (0) 800 31 969 80**

Proof of purchase should accompany the returned unit to avoid delay in investigation and dealing with your claim.

You should obtain appropriate insurance cover for any loss or damage which is not covered by Stuart Turner Ltd in this provision.

Please record here for your records.

TYPE NO.	SERIAL NO.	DATE PURCHASED



**DECLARATION OF CONFORMITY**

**Machinery Directive – 2006/42/EC**

BS EN 12100, BS EN 809

**Low Voltage Directive – 2014/35/EU**

BS EN 60335-1, BS EN 60335-2-41

**EMC Directive – 2014/30/EU**

BS EN 55014-1, BS EN 55014-2, BS EN 61000-3-2, BS EN 61000-3-3,  
BS EN 61000-4-2, BS EN 61000-4-3, BS EN 61000-4-4, BS EN 61000-4-5, BS EN 61000-4-6,  
BS EN 61000-4-11

**EMF Directive – 1999/519/EC**

BS EN 62233

**RoHS Directive – 2011/65/EU**

IT IS HEREBY CERTIFIED THAT THE STUART ELECTRIC MOTOR DRIVEN PUMP AS SERIAL NUMBER BELOW, COMPLIES WITH THE ESSENTIAL REQUIREMENTS OF THE ABOVE E.E.C. DIRECTIVES.



RESPONSIBLE PERSON  
AND MANUFACTURER

STUART TURNER LIMITED  
HENLEY-ON-THAMES, OXFORDSHIRE  
RG9 2AD ENGLAND.

Signed .....  ..... Technical Director

Stuart Turner are an approved company to BS EN ISO 9001:2015



Stuart Turner Ltd, Henley-on-Thames, Oxfordshire RG9 2AD ENGLAND

Tel: +44 (0) 1491 572655, Fax: +44 (0) 1491 573704

info@stuart-turner.co.uk www.stuart-turner.co.uk