

AKW[®]
Life Made Better

Monobloc Spray Wash Basin Mixer Tap

INSTALLATION INSTRUCTIONS

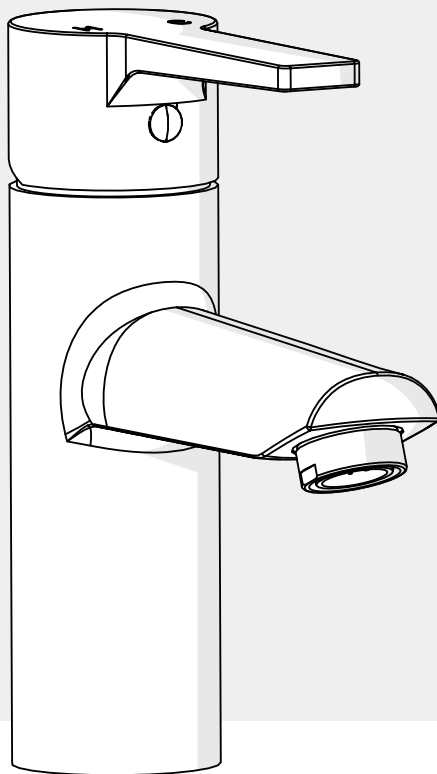

Please read all instructions before installation and leave this document with the end user for future reference as it contains important warranty information

Important Information

Dimensions and Parts

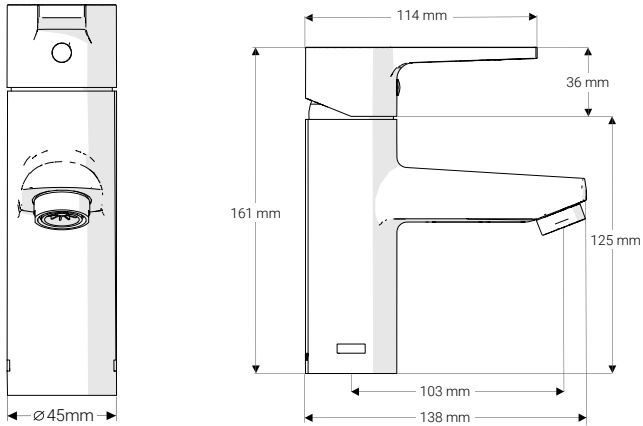

Ref	Description	Qty
A	Basin mixer tap	1
B	Seat ring	1
C	Flexible connector hose	2
D	Rubber horseshoe washer	1
E	Metal horseshoe washer	1
F	Stud	1
G	Fixing Nut	1

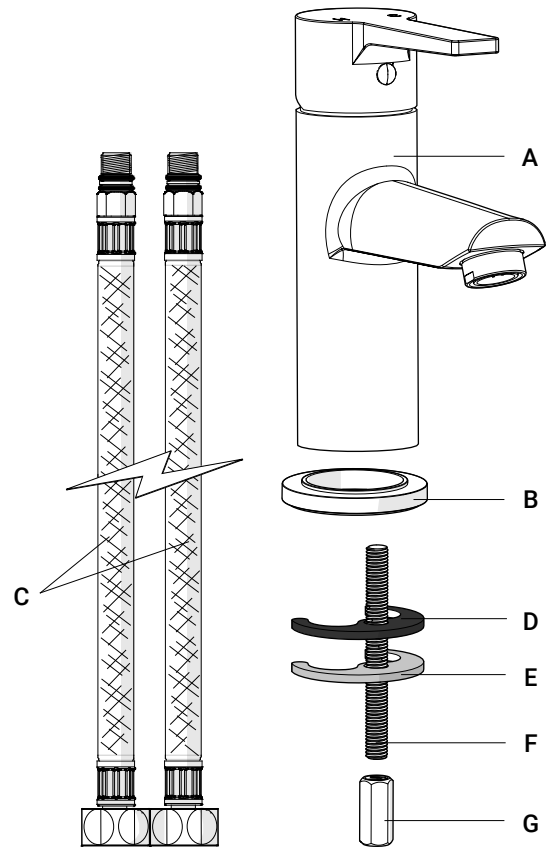

This product must be installed in compliance with Water Bylaw Regulations. You may need to fit a flow limiter to meet local requirements, see table below for tap performance.

Hot and cold water supply pressures should be balanced, isolating and non-return valves should be fitted.

If you are unsure, please obtain the advice of a professional plumber before attempting any work.

Minimum working pressure 0.2 bar.

Flow Rate for Tap

Tap Flow Performance						
Tap Flow Rate (without Flow Limiter)						
Dynamic pressure	1 bar		3 bar		5 bar	
	Position 1	Position 2	Position 1	Position 2	Position 1	Position 2
Full cold/hot water	7.89 L/min	12.1 L/min	9.68 L/min	21 L/min	12.8 L/min	27.18 L/min
Mixed water	7.26 L/min	13.9 L/min	9.92 L/min	24.6 L/min	10.93 L/min	32.5 L/min



Fig. 1

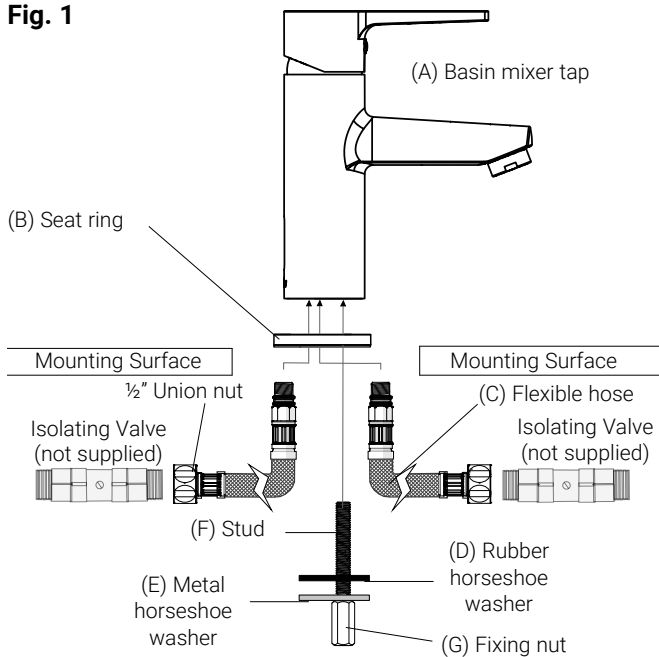

- 1 Fit flow limiters (not supplied) if required.
- 2 Feed the flexible hoses (C) through the hole in the mounting surface.
- 3 Place the tap onto the mounting surface with the seat ring (B) under the base of the tap.
- 4 Feed the washers and nut onto the stud in the order shown below, and then tighten the nut.
- 5 Connect the flexible hoses to the water supply. The markings on the side of the tap at the base indicate which hose is which. Using isolator valves (not supplied) is recommended.

Fig. 2

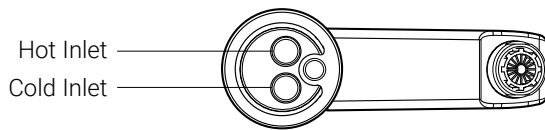
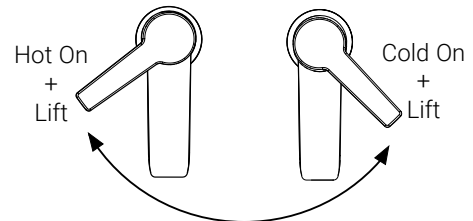

Fig. 3



Commissioning

Open isolating valves and check for leaks.
 Turn tap head to cold and lift to turn on.
 Allow a few minutes of cold running and then repeat for the hot water.
 Turn off and check for further leaks.

Cleaning and Care

Clean using warm, soapy water only.
 Do not use scourers or abrasive cleaners which may affect the surface finish.
 Never use corrosive acidic or alkaline cleaning materials on fittings or surfaces.
 Always flush cleaning materials away with copious amounts of water and wipe down to dry.

Contact Us

AKW[®]
Life Made Better

Orders & Quotes

01905 823 299
orders@akw-ltd.co.uk

General Enquiries

01905 823 298
sales@akw-ltd.co.uk

Technical Enquiries

01905 560 219
tech@akw-ltd.co.uk

Kitchen Enquiries

01905 823 262
kitchens@akw-ltd.co.uk

Fax

01905 823 297

AKW

Pointon Way, Hampton Lovett
Droitwich Spa, WR9 0LR

www.akw-ltd.co.uk
orders.akw-ltd.co.uk

Follow us on Social:



Warranty

Warranty applies only to manufacturing or material defects, conditional on the one-time correct installation of the product. It does not apply to:

- Inappropriate use or accidental damage.
- Damage or defects that result from incorrect installation.
- Lack of maintenance including the build up of grime or damage resulting from inappropriate cleaning.
- Damage or defects that result from repairs or modifications undertaken by unauthorised persons.
- General wear and tear through usage and does not apply to surface finishes.

Warranty period starts from the date of installation. See the T&Cs on our website for further information.

Select 1 of 2 ways to activate your warranty



1. Scan using your Smart Device



2. Visit Online

akw-ltd.co.uk/warranty-information

What to do if something goes wrong?

In the event that you encounter a problem with this product, follow the trouble shooting guide if applicable, then contact your local installer. If the issue is still unresolved, contact AKW Technical Enquiries who will provide further advice and arrange for a maintenance engineer to visit if necessary. None of the foregoing affects your statutory rights.