

5yr
Warranty

R N I B

Tried and
Tested

 **Bluetooth®**



BEAB
Approved

Intertek

BEAB
CARE

Intertek

CE

**UK
CA**

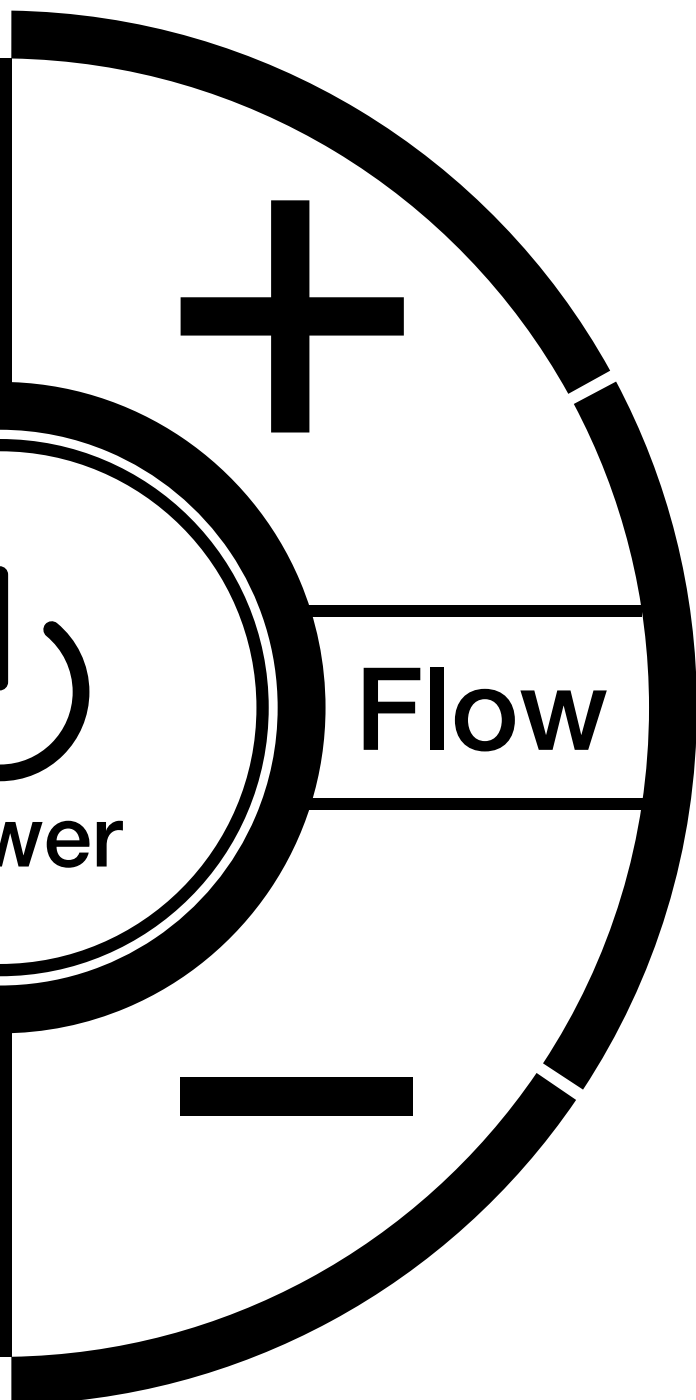

SmartCarePlus

Electric Care Shower

Installation and Instruction Manual

If you require these instructions in braille, audio or large print, please contact us.

Installer - please read all instructions carefully before installation and leave this manual with the end user for future reference

AKW®
Life Made Better

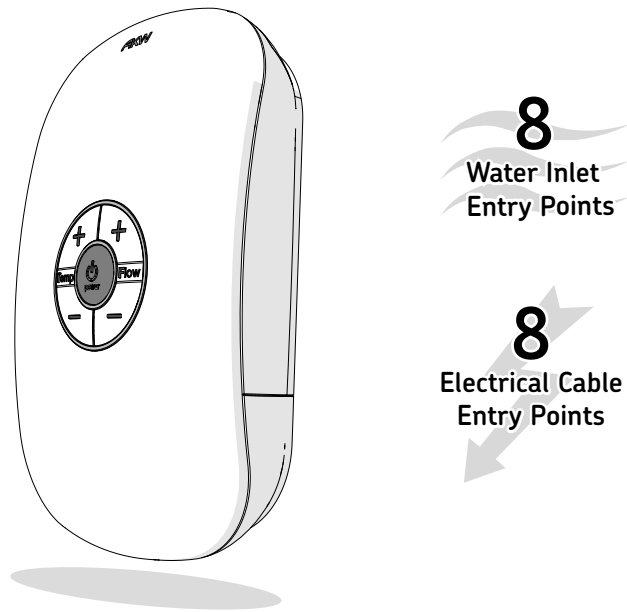

The AKW SmartCare Plus electric shower has been designed to allow for easy operation. The large ergonomic interface clearly indicates the temperature and flow rate on the LED display, whilst generating audio/visual feedback for the user. The AKW SmartCare Plus electric shower also has tactile information on the interface, for greater reassurance to any user.

Automatic Shut Down - The shower automatically shuts down after 30 minutes operation (this can be bypassed 30 seconds prior to shut down)

Phased Shut Down - Flushes the shower with cold water to avoid the possibility of scalding if the shower is restarted within a short period of time

Bluetooth® - The shower can be controlled by an AKW Shower Remote Control (Stock Code: 29013) or the AKW Shower App for smart devices - available to download for free on the Apple App Store or Google Play for Android devices

Flexible Installation - 8 water and cable entry points

Dual power blocks for left or right wiring

Retro-fit footprint

5 year warranty

8.5, 9.5 or 10.5kW options available

Wired and wireless connectivity to all AKW DigiPump shower waste pumps

Introduction	2-3
Product Features	2
Contents	3

User	4-9
Safety Information	4
Operating Instructions	5
Volume Settings	6
Maintenance and Cleaning	7
Troubleshooting	8
Warranty	9

Installer	10-17
Main Components	11
Specifications	12
Installation Requirements	13
Disassembly	14
Fitting to wall	15
Reassembly - Bottom Cover	16
Reassembly - Front Cover	17

Plumbing	18-21
Water Requirements	18
Plumbing Connections	19
Plumbing Entry Points	20
Check List	21

Electrical	22-25
Electrical Requirements	22-23
Electrical Entry Points	24
Connecting Waste Pump	25

Commissioning	26-34
Temperature & Mode Settings	26
Cold Water Flushing	27
Functional Checks	28
Troubleshooting For Engineers	29-30
Cleaning the Filter	31
Commissioning/in-service tests	32-33
Service Record	34

Failure to install this AKW product in accordance with supplied instructions or the making of unauthorised modifications will invalidate any warranty and may affect product safety.

Please ensure the warranty card details are filled in and returned in the envelope provided. Alternatively visit our website and register online. www.akw-ltd.co.uk/warranty

These instructions are provided to advise the minimum standards of installation and recommend the best practice for the installation. Due to the wide variability of possible installation conditions, AKW cannot provide every solution for the installation. AKW does not accept any liability in connection with this information or its use. This information is provided on the condition that the person receiving it shall make their own tests to determine the suitability for their particular purpose. None of the foregoing affects your statutory rights.

This appliance can be used by any persons (including children from 8 years and above) with reduced physical, sensory, mental or intuitive capabilities or by any persons with a lack of experience and knowledge of showering, only if they are supervised or have had the correct instructions on how to operate the appliance correctly.

Children should be supervised to make sure that they do not play with the appliance and use it correctly. Ensure that the temperature is not set to maximum before showering. Sunburn or skin conditions can increase your sensitivity to hot water. Make sure that you set the shower to a cooler temperature.

Do not operate shower if you suspect the water in the heater tank is frozen or the appliance has been susceptible to freezing conditions.

Do not operate the shower if the spray handset or hose is damaged, twisted or blocked in anyway.

Do not restrict flow out of the shower by blocking or obstructing the hose or spray handset.

Do not use other shower hoses and handsets with this shower. Using other handsets or hoses will make this SmartCare Plus shower a Non-Care approved shower. Only use AKW approved products.

Factory Temperature Settings

The shower is set to **43°C** in its factory setting when packaged.

This is not Care approved at this temperature.

To comply with BEAB Care standard and to be Care approved, then the maximum temperature DIP switch setting must be changed to 41°C.

The maximum water temperature can be set to either 41°C, 43°C or 47°C by changing the DIP switch settings located on the control PCB inside the front cover - see page 26. Do not attempt this yourself unless you are a competent installer and have read all of these instructions before doing so.

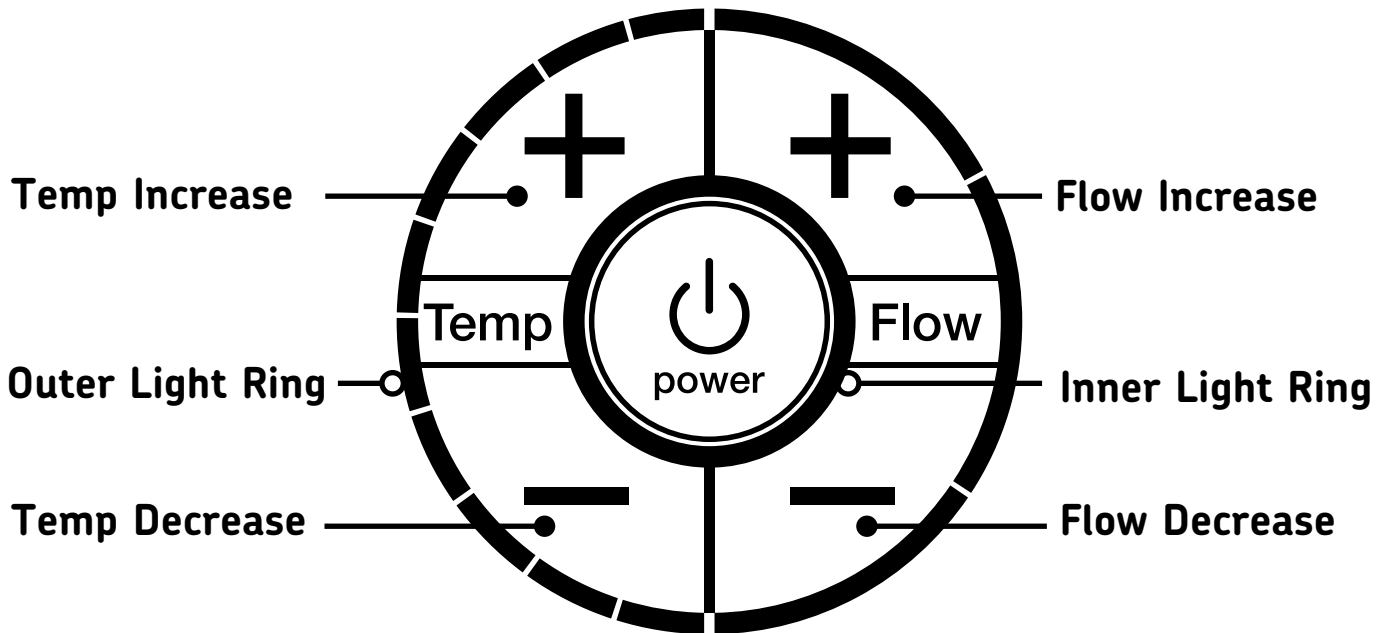

Starting the Shower

Switch on the mains power at the isolating switch.

When power is applied, the inner light ring will be dimly lit and the shower is in standby mode.

To switch on, press the power button. The inner light ring will be brightly lit.

The outer light ring will now indicate Temp/Flow settings

Temperature and Flow Setting

Pressing and releasing

Temp (+) increases outlet water temperature

Temp (-) decreases outlet water temperature

Flow (+) increases outlet water flow rate

Flow (-) decreases outlet water flow rate

NOTE:

Changes in the flow rate and water temperature may take a few seconds to reach the handset.

Step 1

Enter Volume Setting

When in Standby.
Press and hold
Temp (+) and Flow (+)
simultaneously for
3 seconds to enter
Volume Set Mode

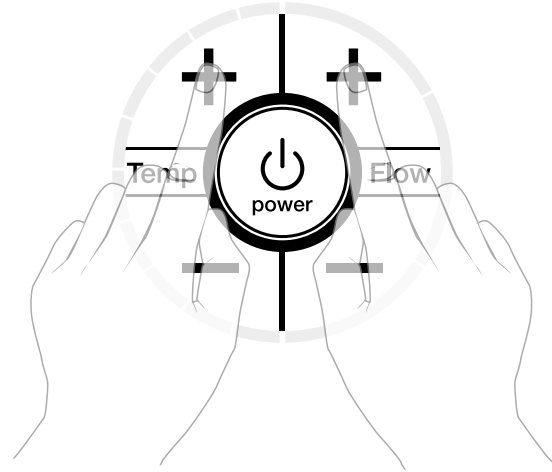

Step 2 Adjust Volume Level



Mute



Min.



Default



Max.

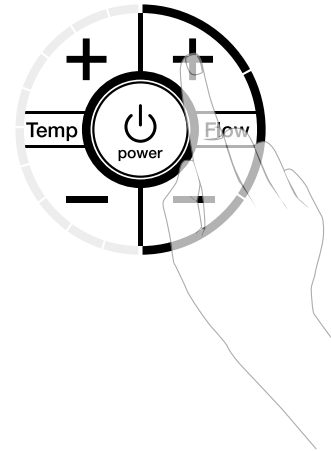
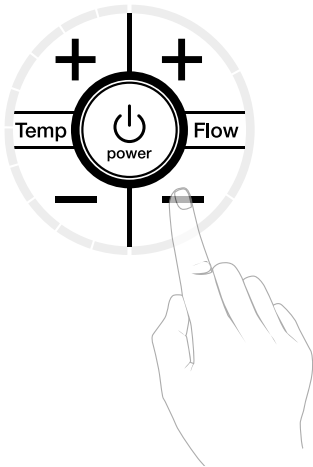

Step 3

Exit Volume Setting

Press Temp (-) to
save the settings. The
shower will revert to
Standby mode when
complete.

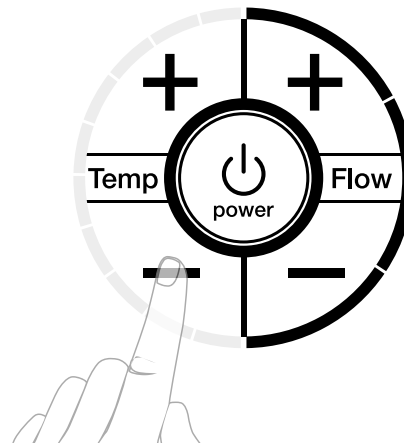

Always isolate power supply before cleaning. Do not operate if the shower unit is frozen. Clean and descale the shower head regularly.

The shower unit and surrounding areas should be cleaned periodically to remove any accumulation of dirt or other waste materials, using domestic bathroom and kitchen cleaning materials with a soft cloth.

Do not use abrasive pads or cloths. Do not use strong or concentrated acidic, alkaline or other cleaning materials as these may damage or discolour the product.

After cleaning always wash down with water then wipe thoroughly with a damp soft cloth to remove any cleaning material residue.

DO NOT position the handset to spray water directly on to the appliance.

Children should be supervised at all times if they use the shower appliance or attempt to clean it.

Read and understand the user guide before commencing troubleshooting

Symptom	Possible Cause	Remedy
No Water Flow	Water isolating valve in off position	Turn on water supply
	Filter blocked	Turn off water and electrical supply, remove filter and clean see page 31.
	Thermostat tripped	Turn handset to wall. Perform cold flush. see page 27.
No Lights on	No mains power supply	Turn on the isolating power supply.
Abnormal temperatures	Faulty thermistor	Call your local installer
Reduced water flow	Reduced pressure Blocked hose or handset	Check and clean the handset. Press the flow increase button and/or press the temperature decrease button.
	Water pressure is below minimum requirement. This may be caused by other appliances on the same pipework drawing water	Check other draws offs. Check running pressure (minimum of 0.5bar) (1bar Recommended)
Wireless Pump not responding	Faulty wireless pump link (if installed)	Not Paired No Power to the Pump RF interference
Fault LED's Display (See Page 29 for reference)	Low Flow/Low Pressure Inlet thermistor Fault Outlet thermistor Fault Uncontrolled over temperature	Call your local installer who then should call the AKW technical helpdesk. Refer to back page.

If the shower does not work as expected, switch off at the pull-cord or isolating switch, wait 30 minutes for the shower to reset then switch back on again.

AKW guarantee your shower against any defects in manufacturing or materials for 5 years from the date of installation. Please ensure you have completed the warranty card enclosed and return to AKW within 30 days to activate this warranty offer. Alternatively visit www.akw-ltd.co.uk/warranty and complete the online registration form. Within this period AKW will decide to repair or replace as we may choose. Failure to activate warranty in set period will mean potential charges should a visit to site be required by an AKW Maintenance Engineer. Any action taken under this warranty does not extend the stated 5-year expiry date. Contact information can be located on the back page. This guarantee is in addition to your statutory and other legal rights. None of the foregoing affects your statutory rights.

Not covered by this warranty:

- Damage or defects that result from inappropriate use or accidental damage, incorrect installation, or lack of maintenance including but not limited to the build up of limescale, system debris or pipe scaling, grime, dirt or water-borne debris.
- Damage resulting from inappropriate cleaning or water ingress.
- Damage resulting from water freezing.
- Damage resulting from PRD activation from either a blocked hose or a blocked shower handset.
- If the product is taken apart.
- Damage or defects that result from repairs or modifications undertaken by persons who are not installers or AKW service engineers.
- Malfunction resulting from incorrect use.
- Failure to install in accordance with the installation instructions or performance issues arising from incorrect installation.
- Claim for a defect identified at the point of delivery, once the product is fitted (unless authorisation from AKW Medi-Care Limited has been granted).
- In-situ impact damage.
- Water, electrical, pressure or isolation issues.
- Wear and tear from routine maintenance, cleaning, adjustments, corrosion or erosion.

If you need any advice or if you have any questions, please contact AKW Technical Enquiries with your model number and date of purchase.

For technical faults always refer to the trouble shooting guide before contacting your local installer for assistance. If your installer should need further assistance then contact AKW Technical Enquiries (see back page for contact details).

Installation Instructions

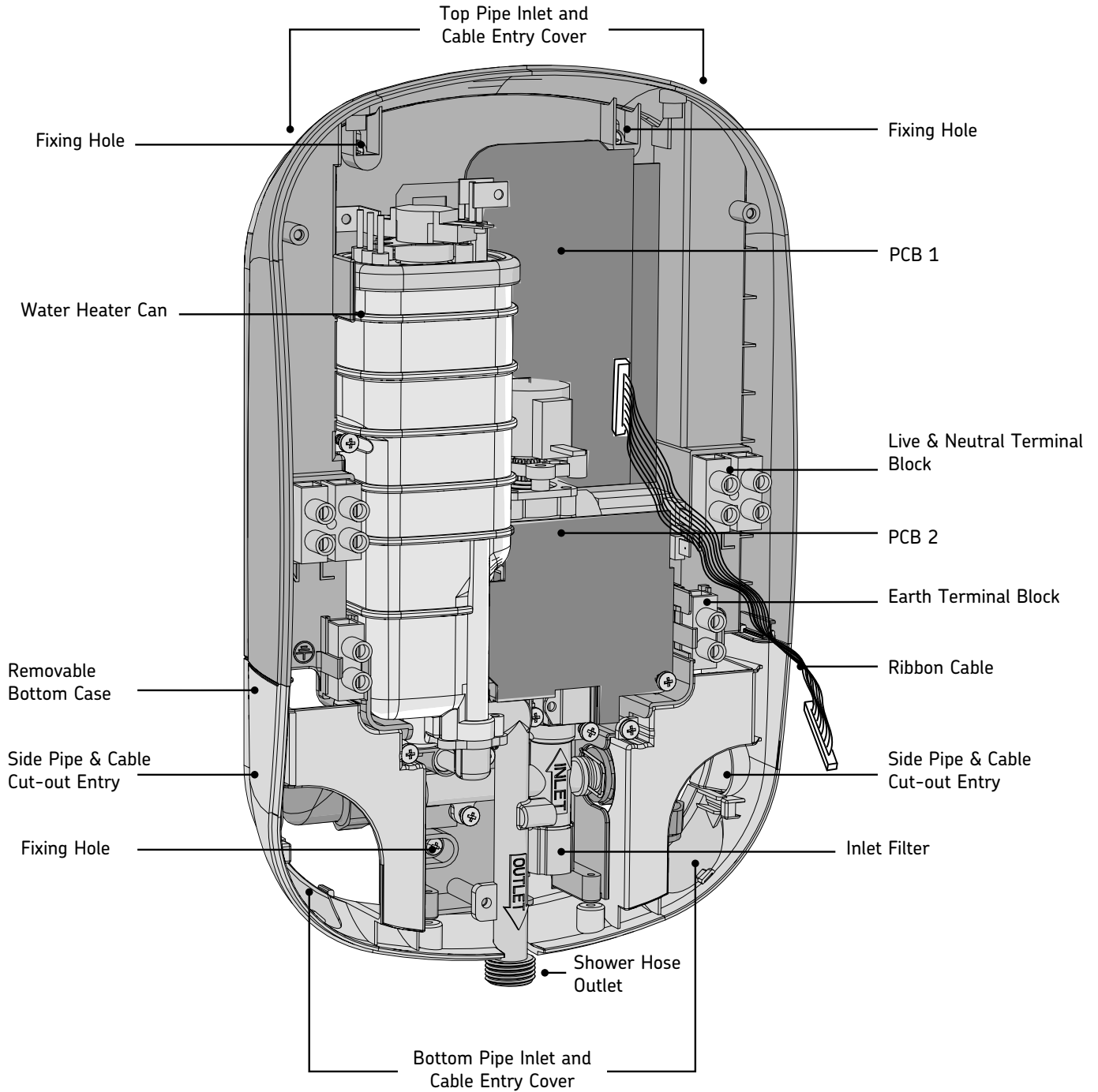

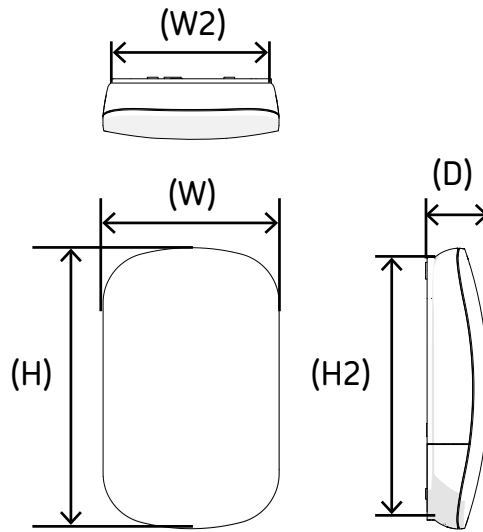

PLUMBING SUPPLY	Supply Source	Mains pressure cold water only
	Minimum Dynamic Pressure	50kPa (0.5 Bar) (1 Bar BEAB Care)
	Recommended Minimum Dynamic Pressure	100 kPa (1 Bar)
	Maximum Static Pressure	1000 kPa (10 Bar)
	Maximum Inlet Temperature	28°C (20°C BEAB Care)
	Minimum Inlet Temperature	3°C (5°C BEAB Care)
	Inlet Connection	15mm pipe
	Outlet Connection	1/2" BSP Male Thread Fitting
ELECTRICITY SUPPLY	Nominal Rating at 240 V	10.5kW, 9.5kW & 8.5kW
	Supply Fuse / Circuit Breaker Residual Current Device (RCD)	(10.5kW 45/50A), (9.5kW 40/45A) & (8.5kW 35/40A) 30 mA (must be fitted)
	Supply Cable	Refer to current wiring regulations and BS 7671 to determine minimum cable size. No larger than 10mm ²
	Isolation Switch (e.g. Pull Cord)	45 Amp Double pole with 3mm contact separation.
PHYSICAL	Height	(H) 380 mm
	Width	(W) 230 mm
	Depth	(D) 85 mm
	Footprint Height	(H2) 345 mm
	Footprint Width	(W2) 210 mm
	Water Ingress Rating	IPX4
	Water and Cable Entry Points	Top, bottom, side or back.
	Shower Drain Pump Connections	Suitable for M Series (Flow Sensor) or AKW A4 (Flow Switch)
	Wired (Wireless optional)	

Installation Requirements and positioning

The shower must only be connected to the mains cold water supply.

The shower must not be positioned where it will be subjected to freezing conditions.
Position the shower unit vertically.

The shower must always be mounted on a finished flat, waterproof surface.
Never tile up to the shower unit.

Do not seal the shower to the wall with silicone or other sealant.

The flat surface must cover the full width and height of the back plate, otherwise difficulty may arise when fitting the cover and subsequent operation of the unit may be impaired.

The water outlet pipe acts as a vent and must never be blocked, restricted or connected to any parts other than those AKW specifically state for use with the AKW SmartCare Plus shower.

Ensure the shower unit is positioned over a bath, shower tray or wet floor.

The shower head must be directed away from the shower unit, during normal use the shower head must not spray directly on to the shower unit.

Before you start work:

Take care when you unpack the product and make sure that you do not inadvertently discard any small parts. Check the contents supplied against the contents page. If any parts are missing or damaged, contact the AKW Technical Enquiries team.

Check there are no pipes or electrical cables inside the wall before drilling.

Check that finished walls are sound and free from cracks or loose tiles or grout. Make sure that all surfaces are clean, dry and free from loose debris or dust.

This product is not suitable for mounting into steam rooms or steam cubicles.

Note; If it is intended to operate the shower in areas of hard water (above 200 ppm temporary hardness), a scale inhibitor may have to be fitted.



Ensure that the electrical supply is switched off at the mains.
Ensure that the water supply is turned off.

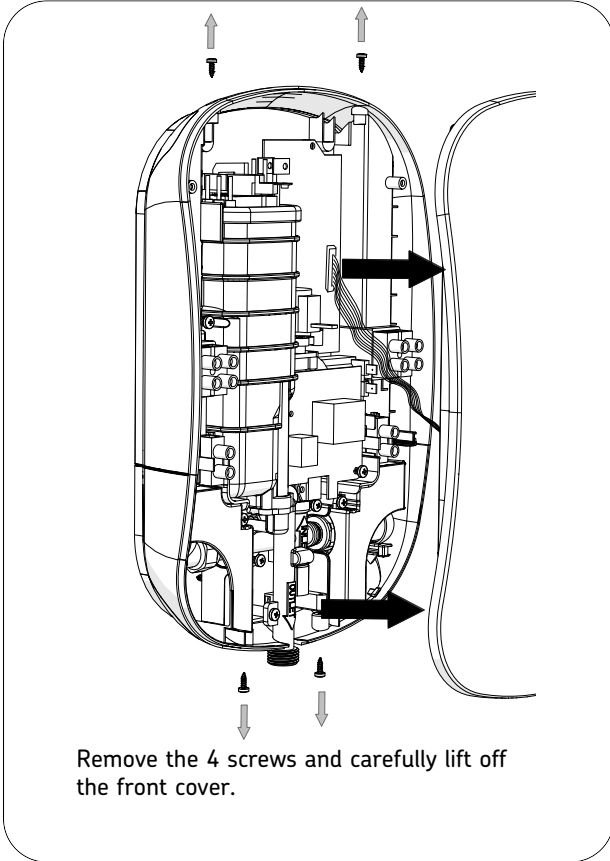

Remove the 4 screws and carefully lift off the front cover.

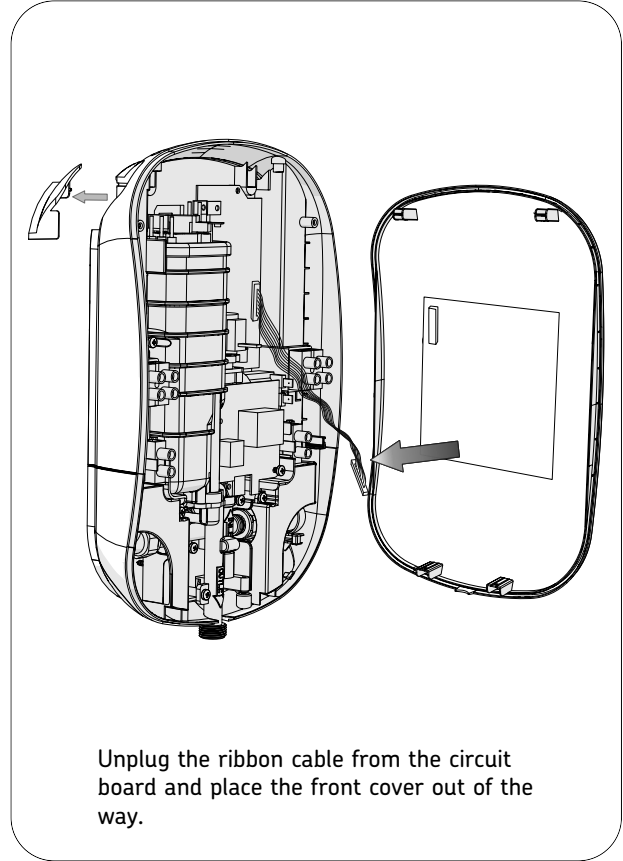

Unplug the ribbon cable from the circuit board and place the front cover out of the way.

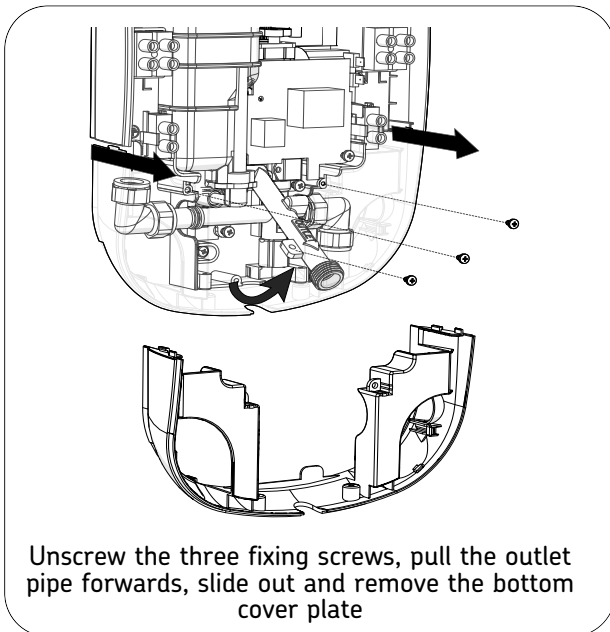

Unscrew the three fixing screws, pull the outlet pipe forwards, slide out and remove the bottom cover plate

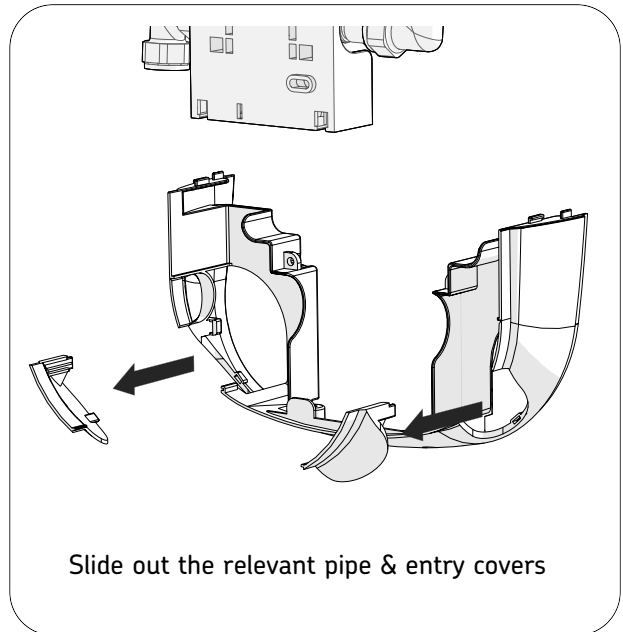

Slide out the relevant pipe & entry covers

Note the unit can be temporarily hung using the top screw fixings whilst the cable and pipe-work entries can be connected.



It is essential to remove any debris and/or brick dust that could otherwise damage the unit.

Do not make any alternative or additional fixing points, as this will invalidate the warranty. Check for hidden cables and water pipes.

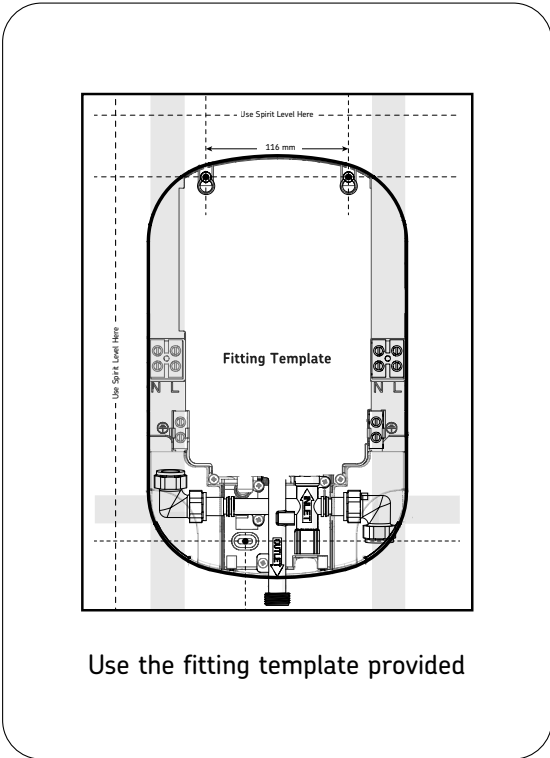

Use the fitting template provided

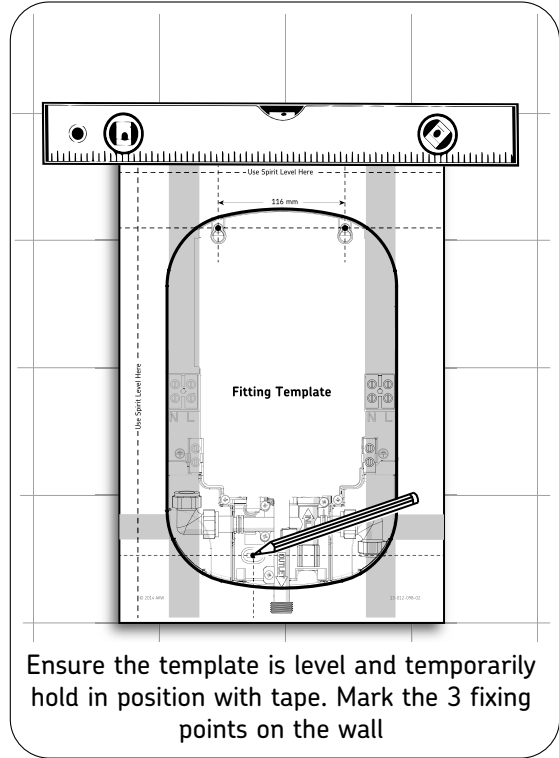

Ensure the template is level and temporarily hold in position with tape. Mark the 3 fixing points on the wall

Tip: use masking tape on tiled walls to prevent slipping and tile splintering. Always use a tile drill bit when drilling tiles.

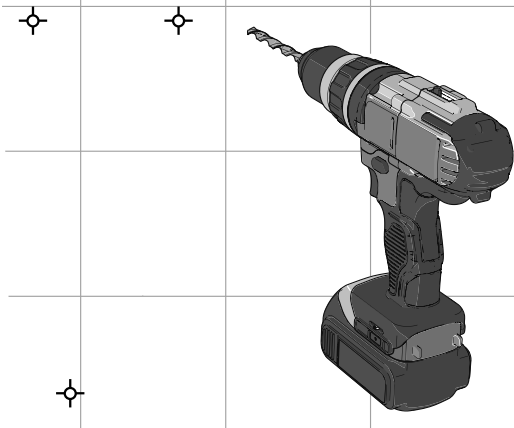

Remove the fitting template from the wall and drill the marked fixing points. Before drilling, ensure there are no cables or water supplies running within the wall

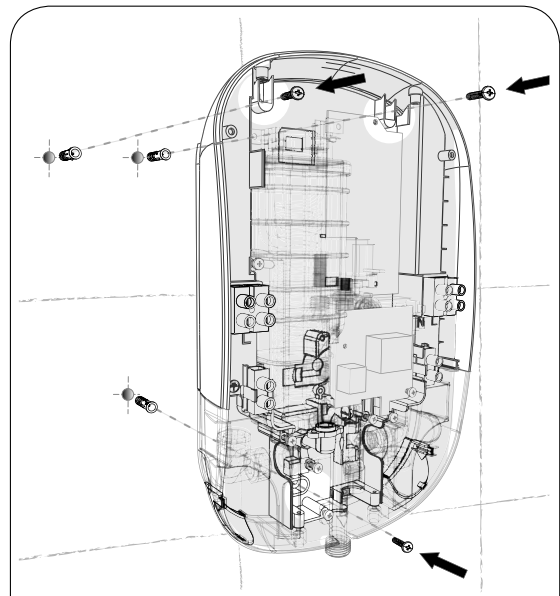

Insert wall plugs and screw the top two screws to the wall. Note: the bottom screw should only be fitted during final installation

Once the cable and pipe connections have been made, reassemble the bottom cover plates.

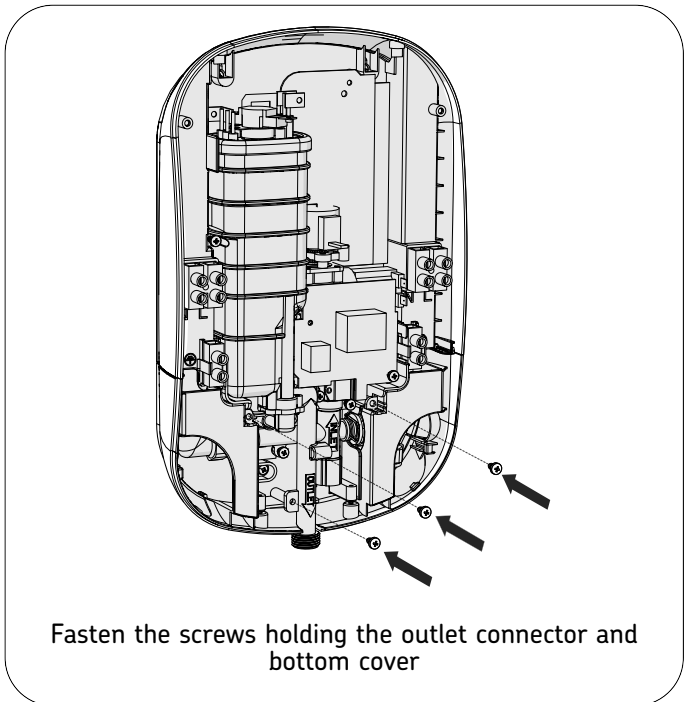
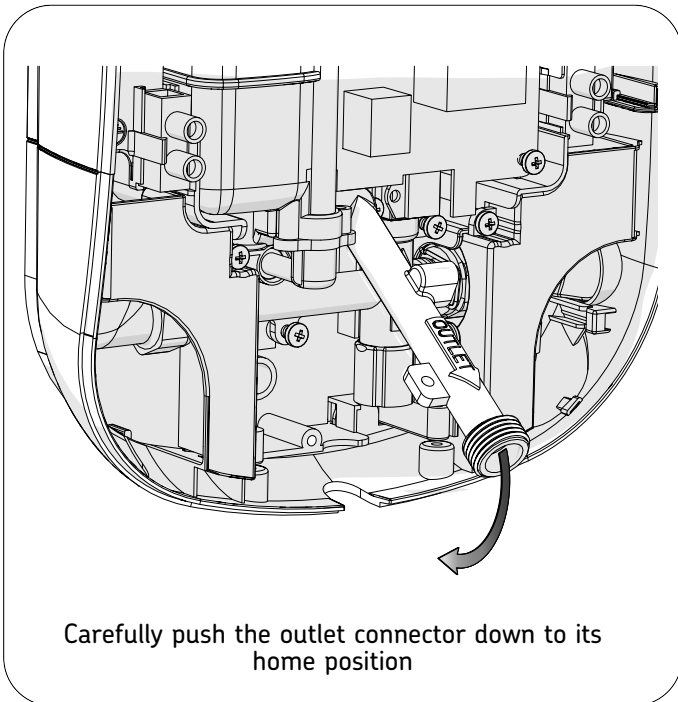
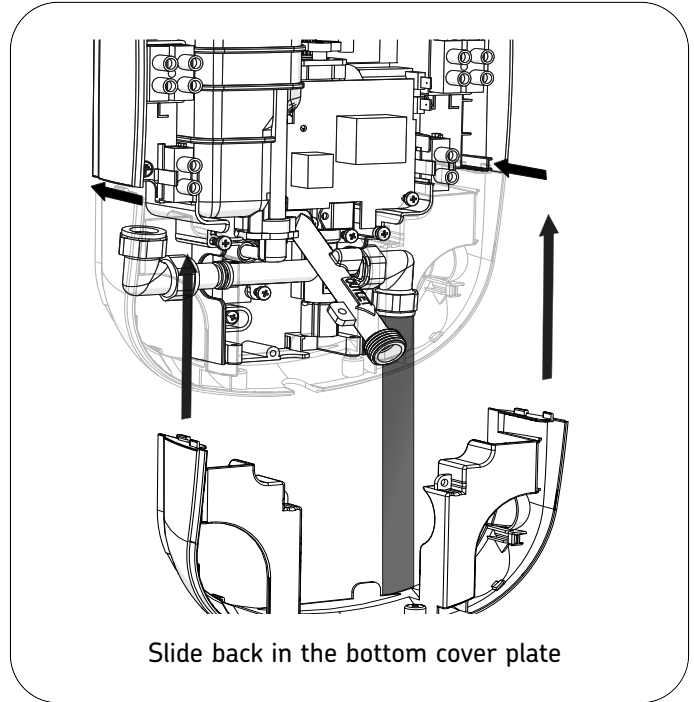
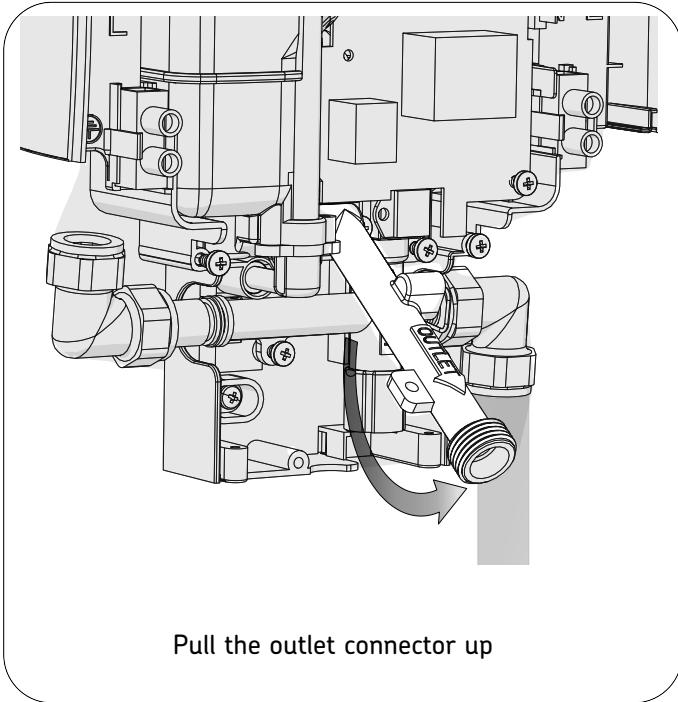

Ensure all connectors are correctly inserted before the cover is refitted.

Refit the Front Cover taking care not to trap the ribbon cable or any other wires.

Only use the supplied screws to secure the front cover. Failure to do so, can cause internal damage to the appliance.

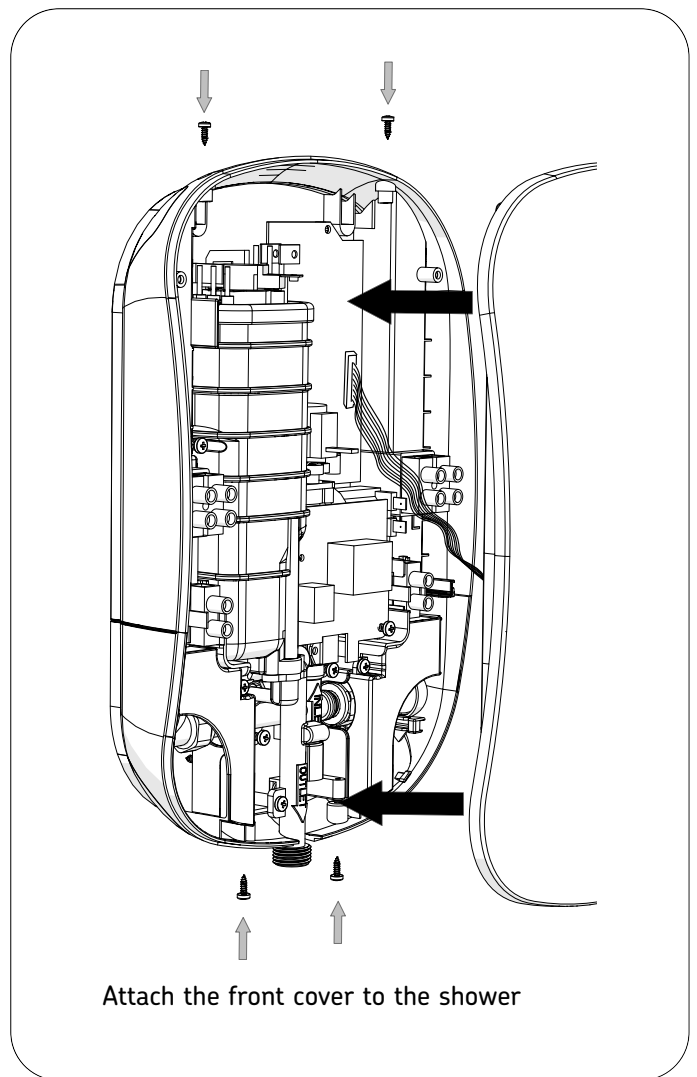
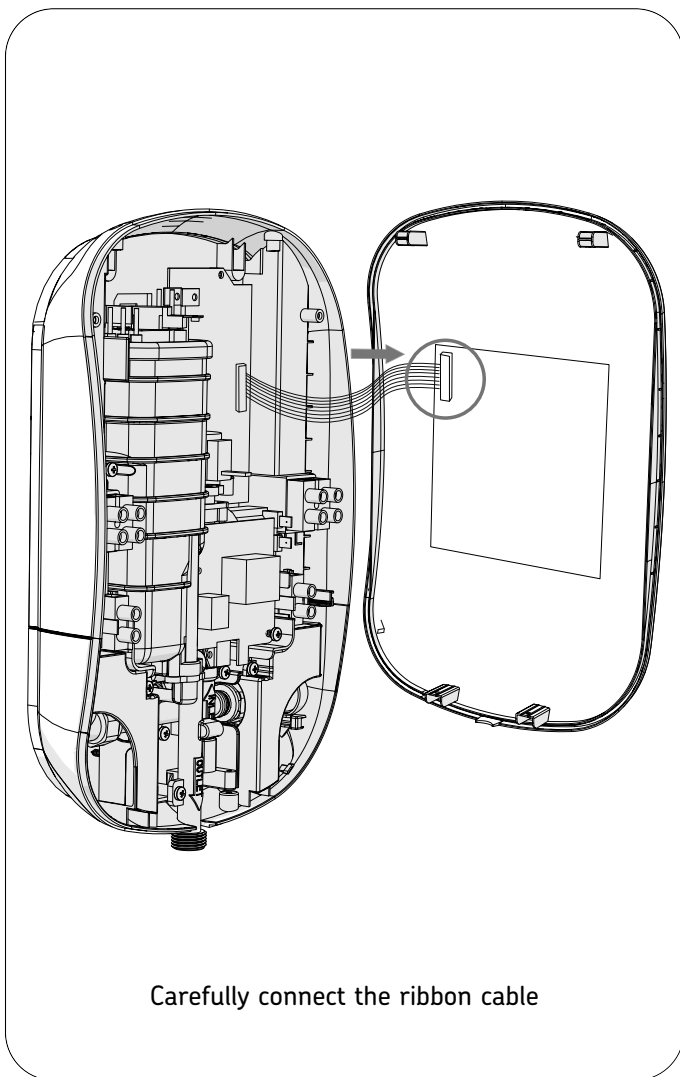

COLD WATER FEED ONLY - Never fit the appliance to the hot water supply.

The shower hose retainer (supplied in the accessory pack) should be used. The installation should comply with Water Regulations and prevent water supply contamination.

To ensure activation of the heating elements, the shower must be connected to a mains cold water supply with a minimum running pressure of 50kPa (0.5 bar) recommended 1 bar with a maximum static pressure of 1000kPa (10 bar).

Note: For optimal product performance the recommended minimum dynamic water pressure should be 100kPa (1 Bar). Dynamic pressure should not fall below 50kPa (0.5 bar) for example when other draw off's are used, such as flushing the toilet as this may cause the shower temperature to fluctuate.

Note: The manufacturer's rigorous quality systems may require operating the shower with water at the factory. Any water will be removed where possible, however there may be a small amount of water residue left in the shower.

There are 8 water inlet points for easy installation and servicing.

The plumbing installation must comply with the local Water Authorities and should be in accordance with the latest Building Regulations.

Plumbing work must be completed before any electrical connections are made.

Make sure there is a cold water feed near to the installation with a local service isolation valve.

Before assembly, flush the water supply pipes thoroughly to remove debris in the pipework (allow the water to run with the main stopcock open for about 3 mins), to prevent debris and dirt particles from blocking the filter which might affect the function of the shower.

DO NOT solder pipes or fittings within 110mm of the shower appliance.

DO NOT fit any form of outlet flow control to the water heater.

DO NOT use excessive force when making connections to the water supply inlet, the flexible hose or the spray head.

Note: An isolating stop valve must be provided on the cold water feed before connecting to the shower. The isolation valve (not supplied) should be fitted as close as is practicable to the water supply inlet of the shower heater whilst being accessible for maintenance and servicing purposes.

Determine pipework position and select the inlet option most suited to your situation. Always prime pipework and flush clear of debris. To prevent a dead leg occurring in the inlet pipework install the inlet plug into the unused inlet pipe, see separate instruction sheet.

Side Entry

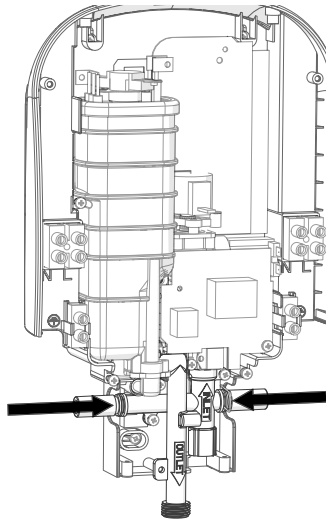

Left or right side inlet. You may need to remove thin areas of plastic cover to facilitate pipe entry.

Rear Entry

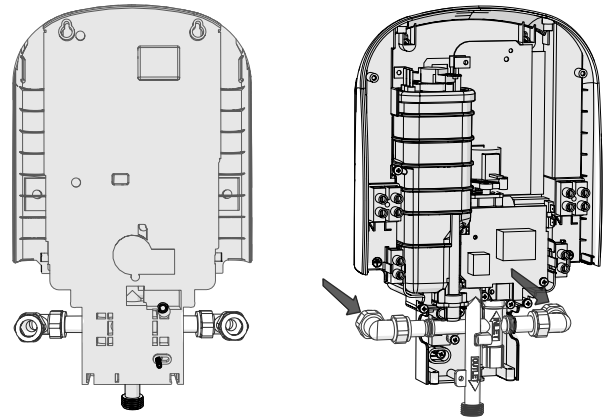

Left or right side rear inlet.

Bottom Entry

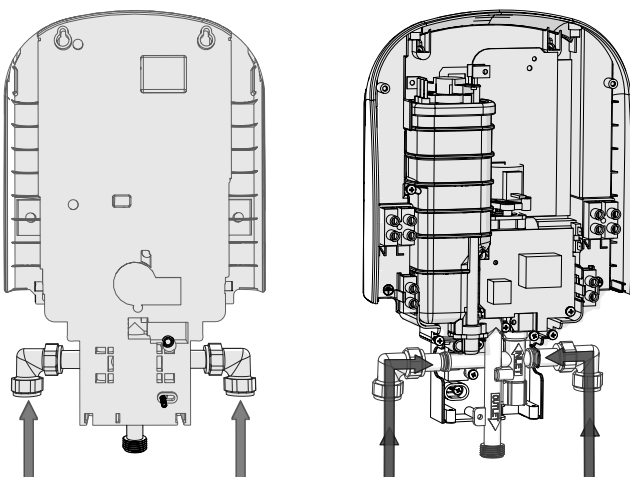

Left or right side bottom inlet.

Top Entry

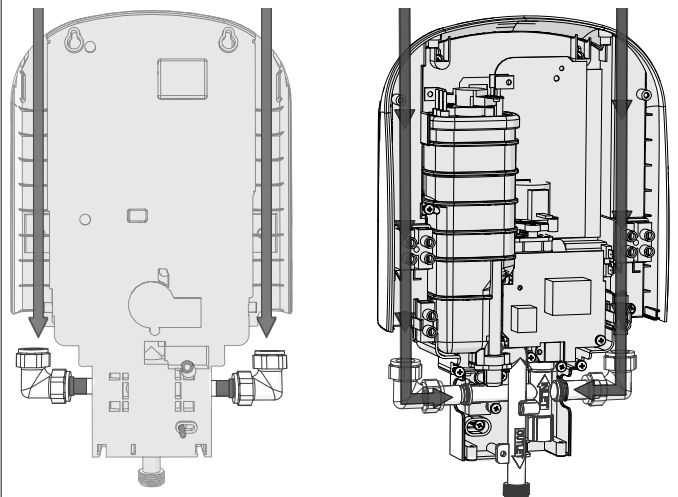

Left or right side top inlet.

Note: Some water from the factory testing may escape when the bottom blanking plug is removed.

CONNECT PIPEWORK AND SECURE THE APPLIANCE TO THE WALL

Separately flush the pipework to remove any debris before connecting to the shower

Note: For ease of installation and servicing, rear entry pipe is only recommended if the top, side or bottom entries are not possible. This pipework must not apply strain to the elbow fitting on the shower. Failure to observe this essential precaution will invalidate the warranty.

Securely fix the shower appliance to the wall and make sure it is vertical.

Do not connect the shower handset yet. Only connect the hose to the shower outlet without the handset at this time and point the hose into the bath, shower tray or wet floor.

Plumbing Check List

- ✓ Check that finished walls are sound and free from cracks or loose tiles or grout. Make sure that the appliance and all surfaces are clean, dry and free from loose debris or dust.
- ✓ The unit must be mounted onto the finished wall or tiled surface (on top of the tiles). DO NOT tile up to or seal around ANY PART of the unit using silicone sealer after fixing to the wall.
- ✓ Turn on the water supply and check there are no leaks - no water should flow through the shower at this point. The maximum static water pressure is 10 bar - The minimum operating dynamic pressure must be at least 0.5 bar. Recommend that for optimum performance this is 1 bar minimum.
- ✓ Place absorbent material around the inlet areas in case of leaks.
- ✓ Checked that there are no leaks
- ✓ Turn off the supply, dry off any water in and around the appliance before connecting or reinstating the electricity.



Caution - Danger of Death 230V AC
Lethal Voltage present on the AC supply.

WARNING - THIS APPLIANCE MUST BE EARTHED

The installation, supply cable and circuit protection must conform to the current wiring regulations and be sufficient for the amperage required and length of cable run. Before making electrical connections within the installation, ensure that the electrical supply has been isolated.

The shower must be connected to its own independent electrical circuit.

DO NOT connect any other device to the power source.

Check your consumer unit (main fuse box) has a main switch rating of 80A or above and that it has a spare fuse way which will take the miniature circuit breaker (MCB) necessary for the shower (see schematic of installation circuit). If your consumer unit has a rating below 80A or if there is no spare fuse way, then the installation may require a new consumer unit serving the property or just the shower. Contact the local electricity company if in any doubt.

The current carrying capacity of the cable must be at least that of the shower circuit protection. Refer to the current wiring regulations to determine minimum cable size. A maximum of 10mm² can be fitted to the shower. Site conditions must be assessed by a competent electrician to determine correct cable size and permissible circuit length.

Shower circuit cable separation from other circuits must meet wiring regulations.

This appliance is only intended to be permanently connected to the main power supply via an independent double-pole isolation switch. Other electrical equipment must not be connected to the same shower circuit. A 30mA residual current device (RCD) MUST be installed. This may be part of the consumer unit or a separate RCD unit.

This appliance must be earthed.

All components must be rated and installed in accordance with wiring regulations. This appliance must be earthed.

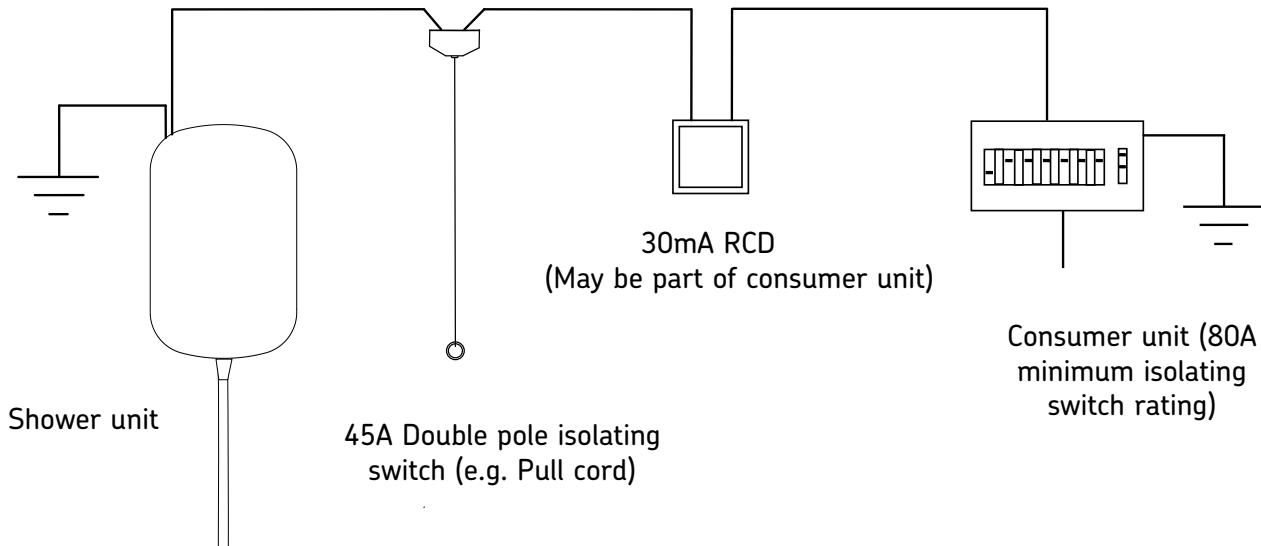

For adequate circuit protection DO NOT use a rewire-able fuse. Instead use a suitably rated miniature circuit breaker or cartridge fuse.

A 30mA residual current device (RCD) must be installed.

A 45 amp double pole isolating switch with a minimum contact gap of 3mm in both poles must be incorporated in the circuit.

The isolating switch must have a mechanical indicator showing when the switch is in the OFF position, and the wiring must be directly connected to the switch.

The isolating switch must be accessible and clearly identifiable, although out of reach of a person using a fixed bath or shower. The cord of a cord-operated switch should be placed so that it is not possible to touch the switch body whilst standing in a bath or shower cubicle.

Where shower cubicles are located outside of a bathroom, all socket outlets in the room must be protected by a 30mA RCD. Consult the wiring regulations.

It is recommended to use the shortest cable route possible from the consumer unit to the shower.

Determine cable entry position

Important: Only connect to Left OR Right terminal blocks. Under no circumstances make connection to Left AND Right terminal blocks

Side Entry

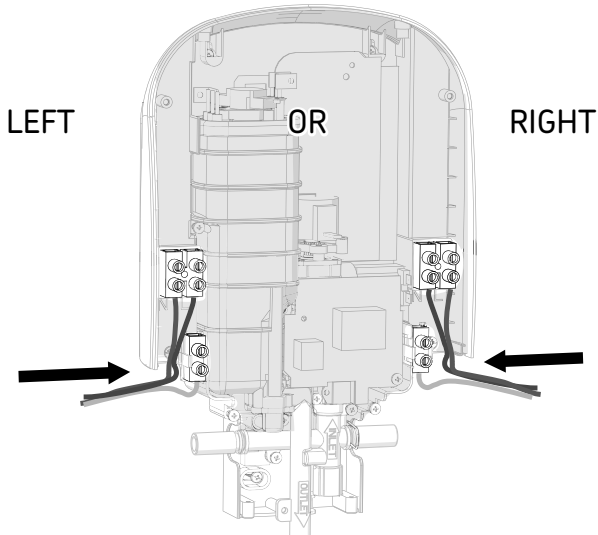

Left or right side cable entry, you may need to remove thin areas of plastic cover to facilitate cable entry.

Rear Entry

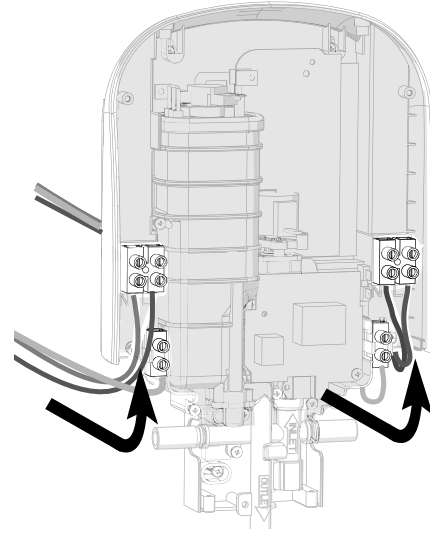

Left or right side rear cable entry.

Bottom Entry

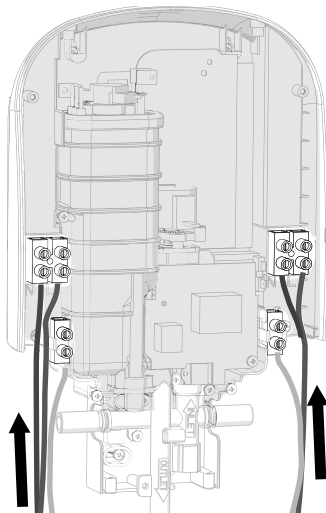

Left or right side bottom cable entry.

Top Entry

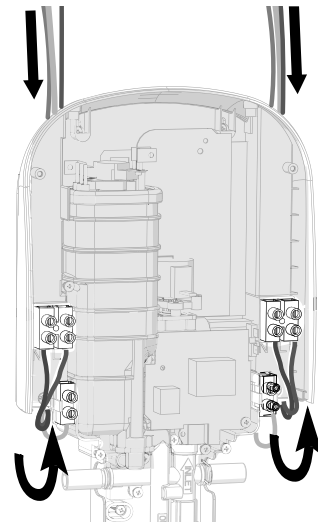

Left or right side top cable entry.

Trim and replace pipe and cable entry covers.

Note: Depending on cable size and entry point used, it may be necessary to strip back the outer cable sheath sufficiently to allow cables to be directed to the terminal connection block within the unit.

Wireless Waste Pump Connections

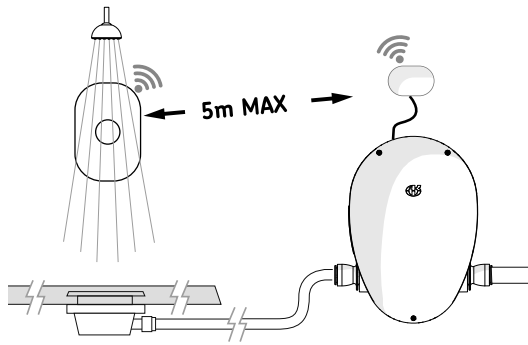

If you wish to connect the pump to the shower wirelessly, an optional wireless pump module is required. Please enquire using stock code: 29089 as a reference and follow the separate wireless pump interface instructions. Select the wireless pump DIP switch setting (Page 26)

Wired Waste Pump Connections

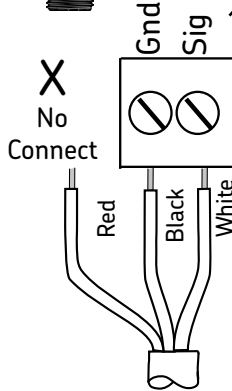
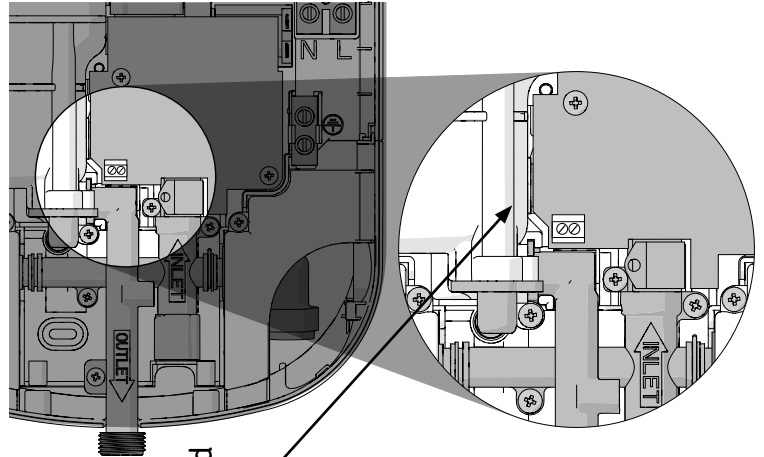

To connect the pump using wired connectivity, using the pump signal wires follow the diagram as shown. Only connect the Black and White wires to the terminal block and remove the Red wire. Select the wired pump DIP switch setting (Page 26)

Selecting your Pump Mode (From Standby)

Switched Mode

Press and hold the “Power button” and “Temp -” button for 5 secs and release. Confirmation beep will be heard.

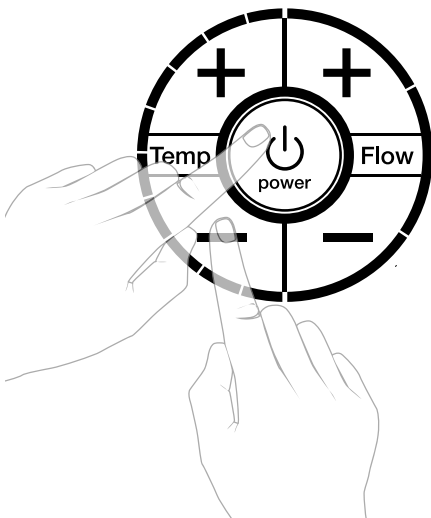

Pulsed Mode

Press and hold the “Power button” and “Flow -” button for 5 secs and release. Confirmation beep will be heard.

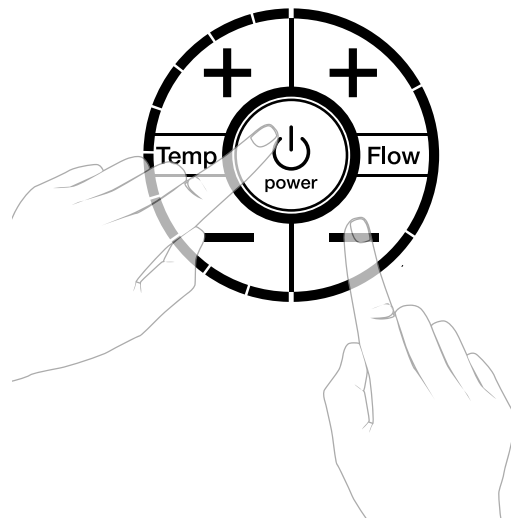

Factory Settings

The shower is set in its factory setting when packaged. This is set to **43°C**.

This is not Care approved at this temperature.

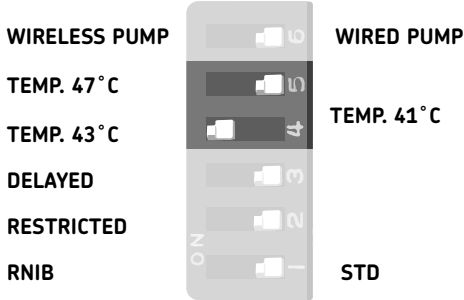

Pump Setting

Refer to Pump Installation instructions for further detail.

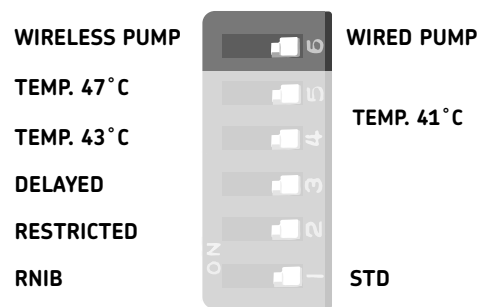

Temperature Settings

To comply with BEAB Care standard and to be Care approved, then the maximum temperature DIP switch setting must be changed to 41°C. Note - When set to 41°C, the shower will beep at isolator switch on. The maximum water temperature can be set to either 41°C, (43°C Factory set) or 47°C by changing the DIP switch located on the control PCB inside the front cover.

MAX. TEMP. 41°C

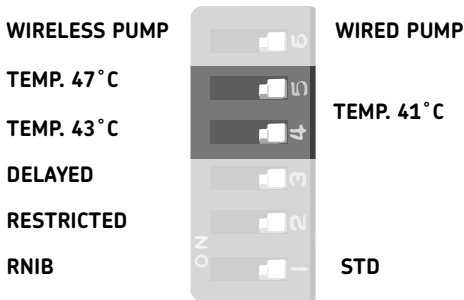

MAX. TEMP. 43°C

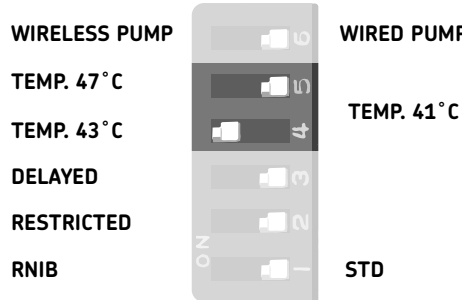

MAX. TEMP. 47°C

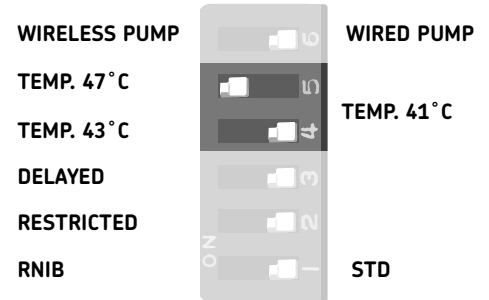

Mode Settings

STD Mode

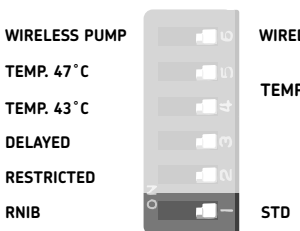

The shower will start at the temperature and flow settings last used when the shower was turned off.

RNIB Mode

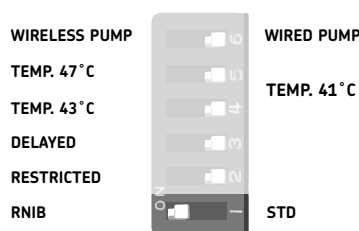

When started, the shower setting will be at a temperature of 38°C. The shower will start at the flow setting last used when the shower was turned off.

RESTRICTED Mode

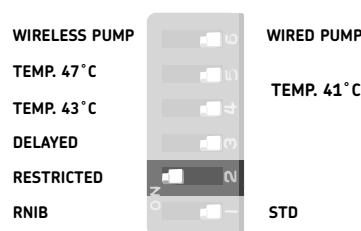

User cannot set the temperature below 38°C. User cannot set the flow below medium

DELAYED Mode

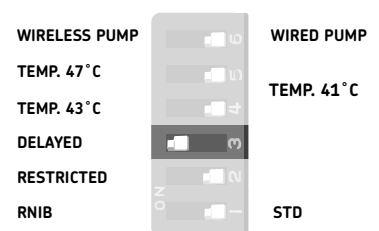

If shower is turned off by remote control or smart device, the shower cannot be restarted manually within 2 minutes. The shower can be restarted immediately by the remote control or smart device that turned it off.

Before operating the shower, it must be primed with cold water using the cold flush setting

Turn on power at pull cord/switch

Press the Flow Increase (+) button (1) and the Power Button (2) simultaneously for 3 seconds.

Release both buttons and cold water will then flow through the unit.
Allow the shower to run until a smooth flow is achieved (approx. 1 minute)

Press the Temp Decrease (-) (3) button to stop the water flow and return the shower to standby mode.
If the Temp Decrease (-) (3) button is not pressed within 3 minutes, the shower will revert to standby mode.

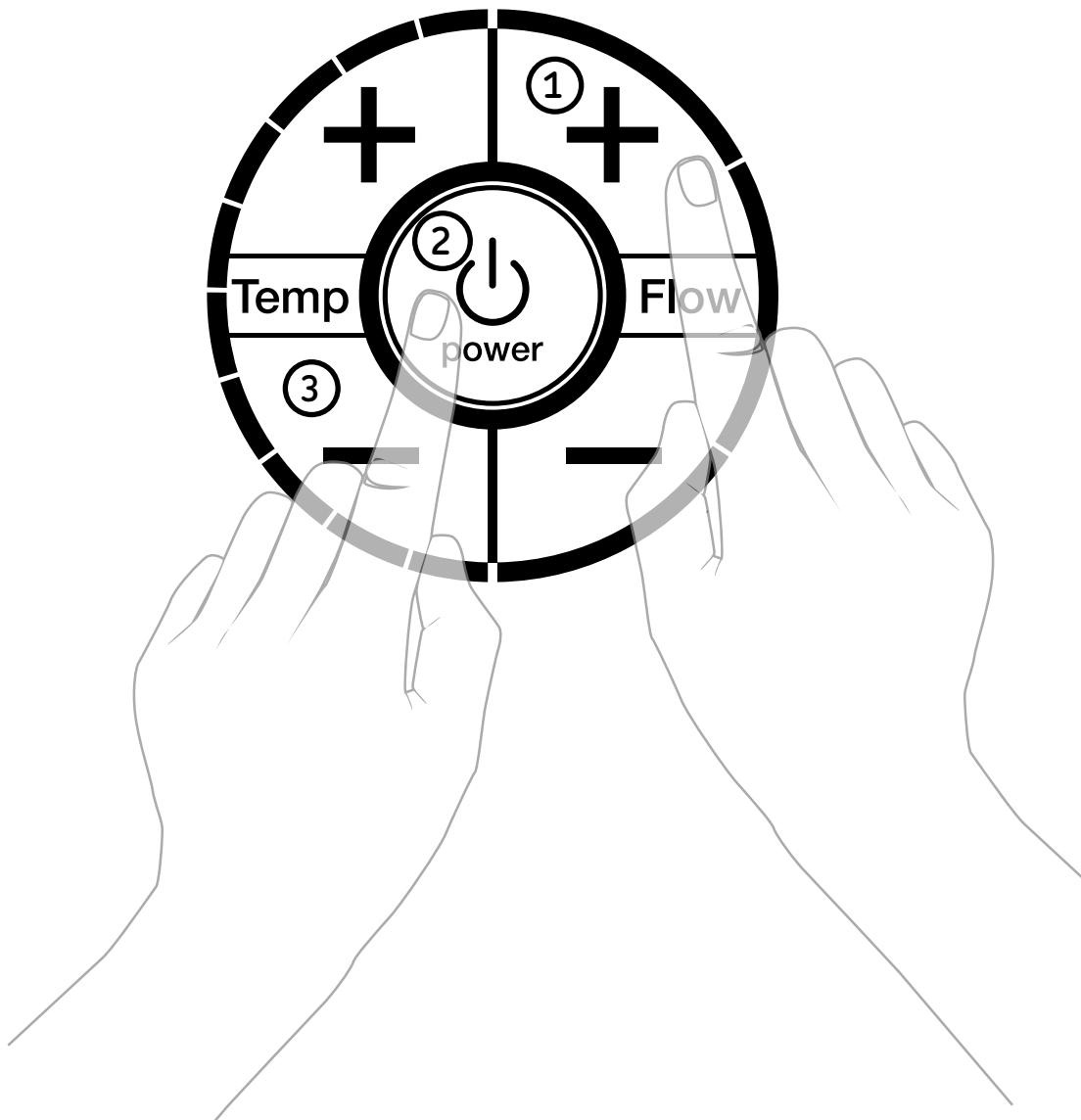

Switch on the shower by pressing the power button.

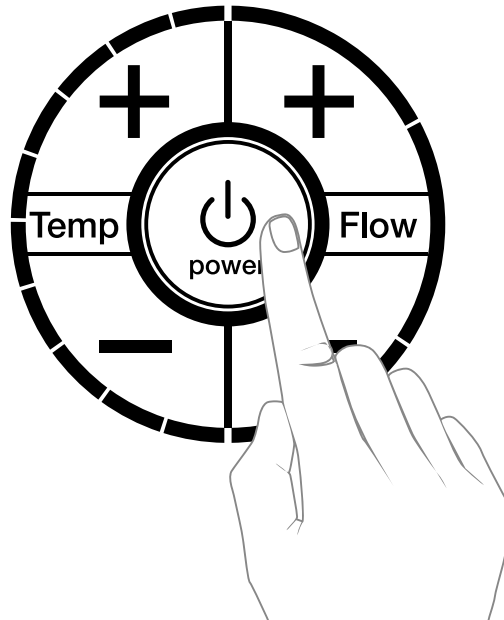

Confirm the operation of the Temperature and Flow increase and decrease buttons, whilst ensuring all lights are functioning

Press the Power button to revert to standby mode

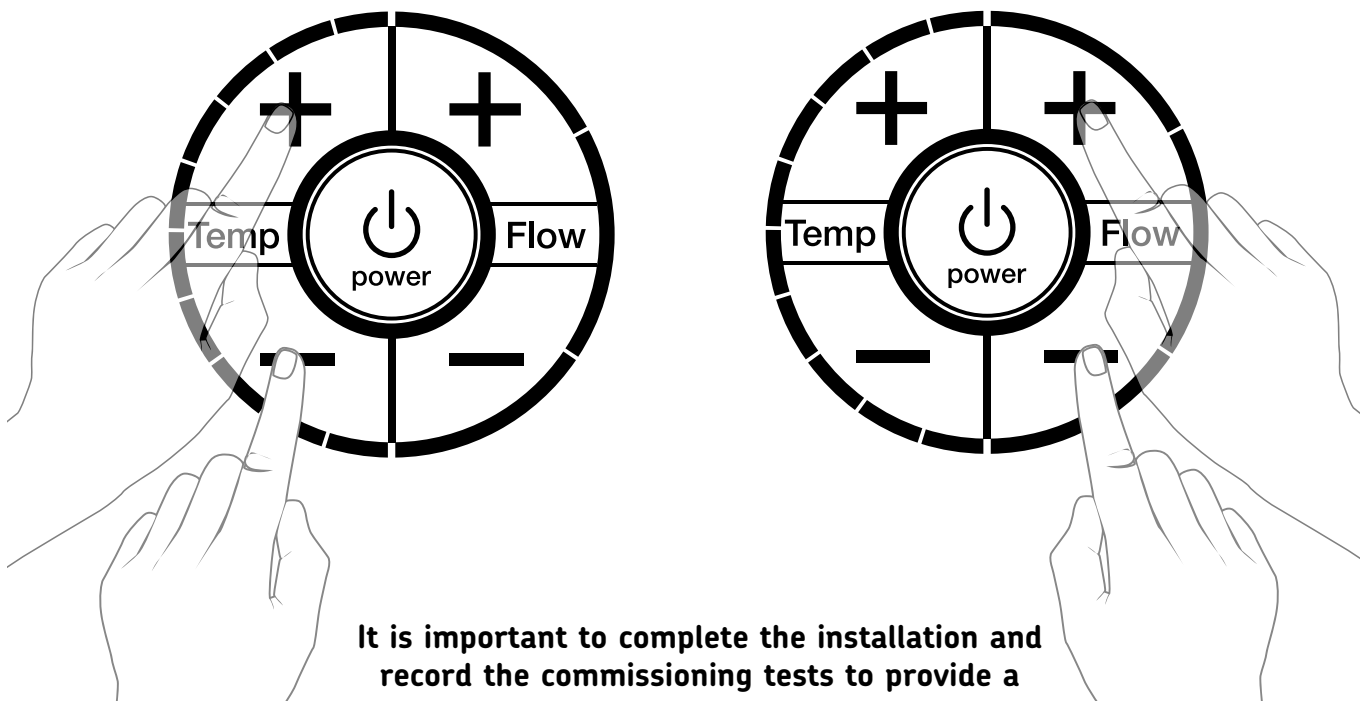

It is important to complete the installation and record the commissioning tests to provide a performance reference point for future tests

In the event that the shower fails to respond to any push-button or exhibits unusual performance characteristics during operation, turn off the electrical supply by operating the pull-cord switch or isolating switch. Wait for a few seconds for the shower to reset, then turn the power back on and push the on/off button. If the problem still persists, note which fault LED is lit or flashing.

Note: Fault signals are assigned to these LED's

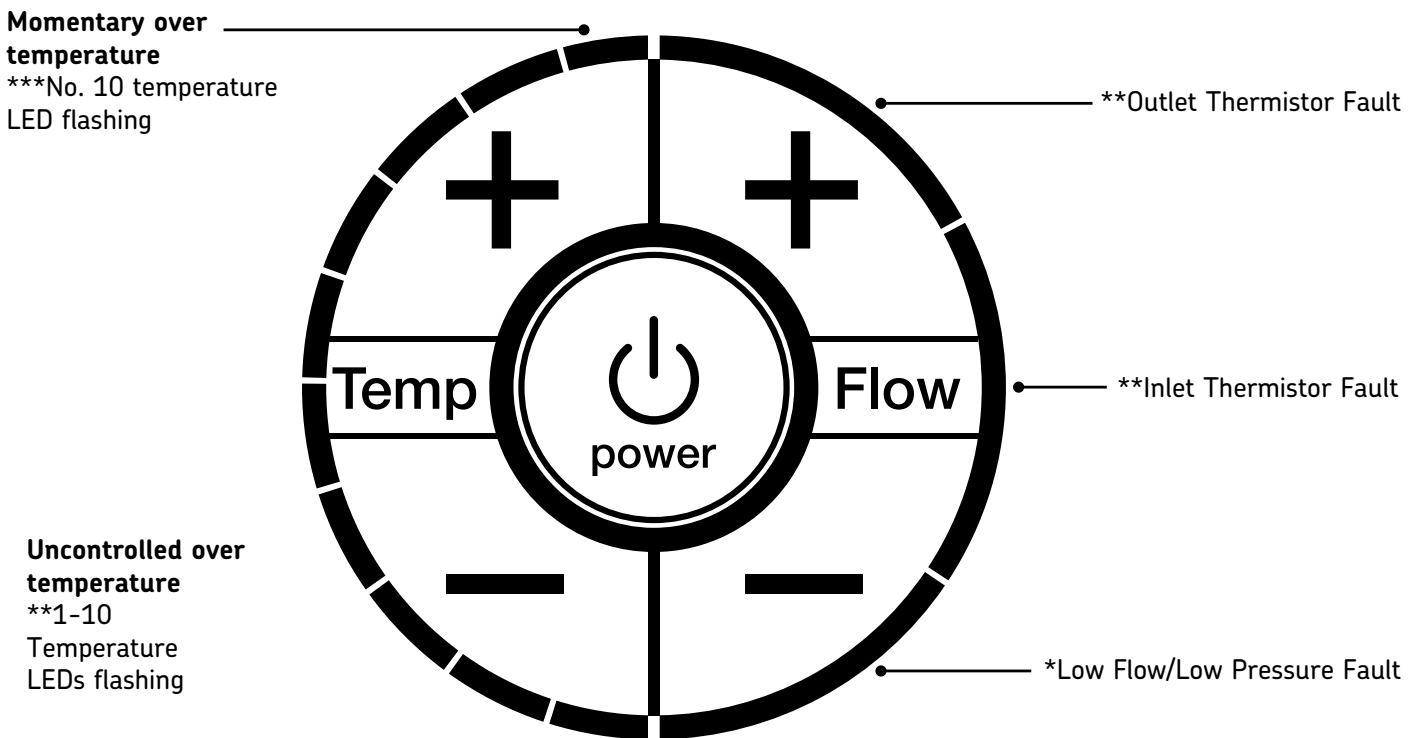

*User resettable when external fault cleared (On/Off pressed and released)

**Requires internal repair / reset

***Automatic reset when over temperature condition cleared (naturally cooling down or by flushing cold water through shower heater).

Overheating

The shower is fitted with an over-temperature indicator and a safety cut-out device. In the event of abnormal operation which could cause unsafe temperatures within the unit, the device will disconnect the heating elements and switch to standby mode.

If the water temperature rises above the desired maximum temperature setting momentarily then ***No. 10 temperature LED will flash at a 2Hz rate. The shower will control the water temperature back to the desired level.

If the water temperature rise is uncontrolled the shower will switch to standby mode prevent an unsafe temperature and the **Temperature LEDs 1 to 10 will flash immediately. The shower will not turn back on until the water inside the unit has cooled to a safe level. Perform a COLD FLUSH to cool the heating elements quicker. If the fault persists then a reset or internal repair may be required. Ensure all electrical connections are tight to prevent overheating.

Low Flow/Pressure Failure

The shower contains a 'LOW FLOW/LOW PRESSURE' indicator which will operate, if the following conditions occur:

- Low water pressure optimum performance is recommended at a constant minimum 1 bar
- Blocked or partially blocked spray plate
- Blocked inlet filter
- Supply flow rate is below 2 litres per minute

If any of the above low pressure conditions occur, the unit will STOP as this will cause the shower to be over temperature and the over temp LEDs will flash. Turn off the electrical supply by operating the pull-cord switch or isolating switch, then turn the power back on and instead of waiting for the shower heater element/tank to cool down, perform a COLD FLUSH.

If the problem still persists then refer to Fault Finding. Ensure all plumbing connections are watertight. Check the hose and shower handset. If the filter is suspected to be blocked, clean it. If the problem still persists, contact AKW Technical Enquiries (see back page for contact details).

This should only be done if you suspect reduced flow rate or water hardness build up.

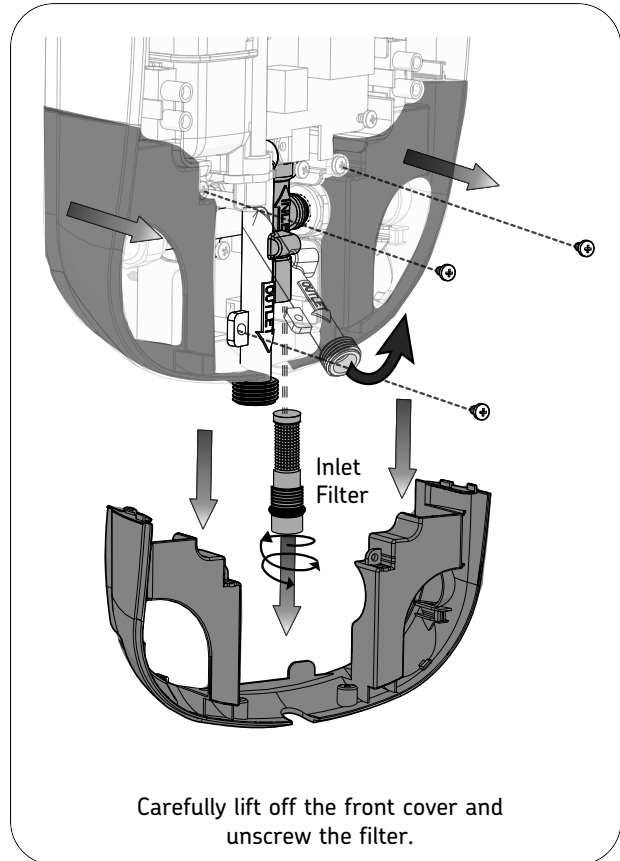
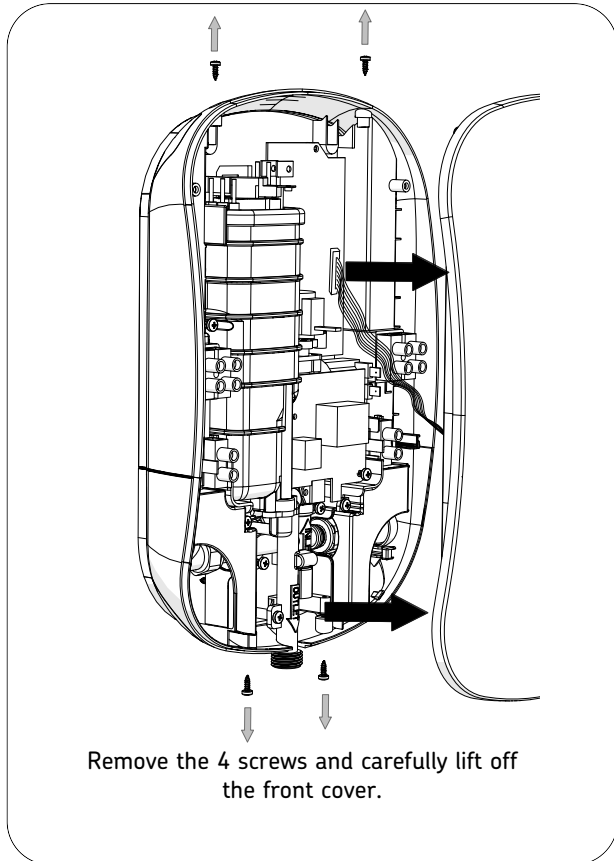

Follow the disassembly instructions on page 14 to expose the inlet filter. Always isolate the electricity supply before opening the cover.

Ensure that the electrical supply is switched off at the mains.
Ensure that the water supply is turned off.

Rinse the filter in water and once this is clean then return to the inlet housing and reassemble.

Commissioning Procedure

With the shower electrical supply isolated, check that the maximum temperature switch (see page 26) matches the intended use; (41° BEAB Care)

With power applied to the shower:

Check terminal voltage at the shower is within the range 230V +/- 10%

Turn on the shower and enter 'Cold Water Flushing' mode (see page 27)

Check inlet water supply temperature is within the range; 3 to 28°C (5 to 20°C BEAB Care)

Exit Cold Water Flushing when completed

Turn on the shower and by pressing the Temp + button, set the outlet water temperature to maximum, and by pressing the Flow + button set the flow rate to maximum. Then carry out the following sequence:

Record the outlet water temperature and flow rate;

Reduce the water supply flow rate at the **inlet** of the shower to 2.5 lpm;

Record the outlet water temperature at the reduced flow rate;

The outlet water temperature should not exceed the maximum temperature switch setting (see page 26).

Record details of test equipment (thermometer, voltmeter, flow meter etc.) used for the measurements.

In-Service Tests

The purpose of in-service tests is regularly to monitor and record the performance of the shower. Deterioration in performance can indicate the need for service work on the shower and/or the water supplies.

Procedure

Using measuring equipment to the same specification as used in commissioning the shower, check that:

The water supply temperature is within the range; 3 to 28°C (5 to 20°C BEAB Care)

The terminal voltage at the appliance is within the range 230V +/- 10%

If the maximum outlet water temperature has changed by more than 1°C from the previous test results, record the change and check

... for any damage/blockage to the shower, inlet filter, hose and handset:

... any in-line or integral check valves or other backflow prevention devices are in good working order;

... any isolating valves are fully open.

With an acceptable outlet water temperature, complete the following procedure:

Record the outlet water temperature and the flow rate at maximum settings;

Reduce the water supply flow rate at the **inlet** of the shower to 2.5 lpm;

Record the outlet water temperature

Record details of test equipment (thermometer, voltmeter etc.) used for the measurements.

If an acceptable outlet water temperature cannot be achieved i.e. temperature is greater than the maximum temperature switch setting (see page 26) by +1° or more then service work is required.

Measuring flow rate

With the shower handset connected, using a measuring jug, collect 1 litre of water and time how long this takes.

60 Divided by the time taken = Flow Rate LPM

e.g. 60 Divided by 20 seconds = 3 LPM

Frequency of in-service tests

General

Following the commissioning of the shower, or any significant repair, the installation should be re-tested within a 6-8 week period.

If no significant changes (eg less than 1°C) in outlet water temperatures are recorded between tests, then the next in-service test can be deferred to 24-28 weeks.

If there is a significant change then contact Technical Enquiries (see back page for contact details).

BEAB Care In-Service Test Record

Serial Number	Address	Location	Date ___ / ___ / ___
			Installer _____

Max.Temp. Dip switch Setting (Care 41)	Condition (Pass/Fail)				Supply Voltage VAC	Water Temperature °C			Flow Rate lpm	Test Equipment Detail	Date (DD/MM/YY)	Signature
						Inlet	Outlet (normal)	Outlet (reduced flow)				
	Shower	Filter	Hose	Handset								

This page may be reproduced for continued recording of in-service testing for the future

-Blank Page-

Orderline
01905 823299

General Enquiries
01905 823298

Technical Enquiries
01905 560219
tech@akw-ltd.co.uk

Fax
01905 823297

Website
www.akw-ltd.co.uk

Quotes & Orders Email
orders@akw-ltd.co.uk

Sales & Enquiries Email
sales@akw-ltd.co.uk

AKW, Pointon Way,
Hampton Lovett,
Droitwich Spa,
WR9 0LR



Social



facebook.com/akwone



twitter.com/akw_one



youtube.com/akwstyleability



linkedin.com/company/akw

As part of our continuous improvement programme we appreciate any feedback on our products and instructions. If you have any tips or comments please let us know!