

BULK PACK OF 10 CARTRIDGES:

Customers wishing to purchase larger quantities of spare thermostatic cartridge A962280NU can order a bulk pack of 10 at a lower cost.
Please contact customer care quoting spares code: F960879NU.

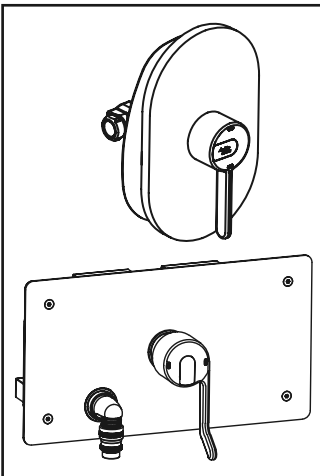

For more information on spare parts why not visit our spare website
www.fastpart-spares.co.uk



IMPORTANT NOTE:
The products shown here will not accept the new type replacement cartridge (A962280NU):

- A4129AA Contour 21 Shower mixer
- A4314MY Contour 21 Shower in a box

IN THESE PRODUCT ONLY use the original cartridge F960968NU.

To replace the cartridge and/or brass seat refer to the details in the main product installation booklet.



For more information about our products visit our websites:

www.armitage-shanks.co.uk

www.idealspec.co.uk

Armitage Shanks pursues a policy of continuing improvement in design and performance of its products.

This right is therefore reserved to vary specification without notice.

Armitage Shanks is a division of Ideal Standard (UK) Ltd

Ideal Standard,
The Bathroom Works, National Avenue
Kingston-upon-Hull, HU 4HS, England

0713 / A 866 386
Made in Germany



AFTER SALES NON RESIDENTIAL HELPLINE
0870 122 8822

AFTER SALES NON RESIDENTIAL FAX
0870 122 8282

E-MAIL
aftersalesnonresidential@idealstandard.com

Ideal Standard International BVBA
Corporate Village - Gent Building
Da Vincilaan 2
1935 Zaventem
Belgium

www.idealstandardinternational.com

Instructions for replacing thermostatic cartridge

Two types of sequential thermostatic cartridges exist. The original (from 2005) having a separate hot seat and the new one (from late 2010) having an integral hot seat.

IMPORTANT NOTE: IF YOU ARE REPLACING AN ORIGINAL CARTRIDGE WITH A NEW SPARE PART, THE HOT SEAT MUST BE REMOVED FROM THE MIXER BODY.
FAILURE TO REMOVE THE HOT SEAT WILL CAUSE DAMAGE TO THE NEW CARTRIDGE.

The two cartridge types are identifiable from the details below.

Fig.1 F960968NU
Original type

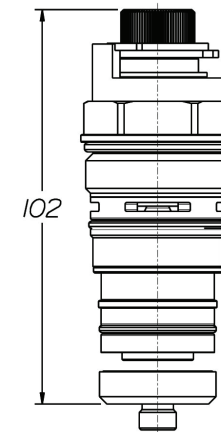

Fig.2 A962280NU
New type

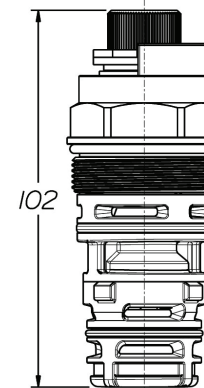
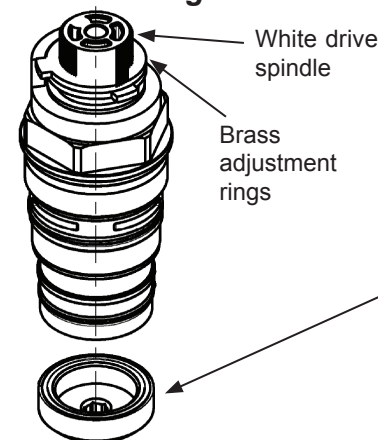

Fig.3 F960968NU original type cartridge



Separate brass seat
(FITTED INSIDE PRODUCT)

Identifying features of the original type cartridge are shown on the left.

If this cartridge was fitted in the product, it will be necessary to remove the brass seat from inside the mixer body.

To remove the seat, you will need the **Seat Extraction Kit No: A963377NU**. See details in the next section.

Fig.4 A962280NU new type cartridge

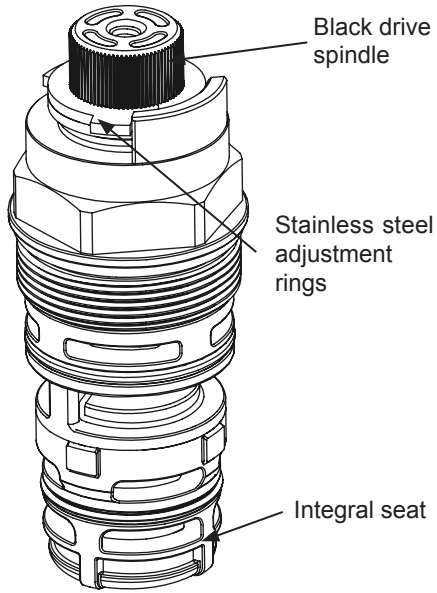

Identifying features of the new type cartridge are shown on the left.

If the spare cartridge **matches** the cartridge being removed from the product, no further action is necessary.

Replacing the Cartridge: Having identified the thermostatic cartridge, remove the cartridge from the product by following the maintenance section of the installation instruction booklet (provided with the product).

- If the cartridge is a direct replacement, proceed to fit the spare part.
- However, if you are replacing an original cartridge, with a new one, follow the next instructions.

Seat Extraction Kit is shown here; it comprises of a 6mm Allen key and a simple extractor tool.

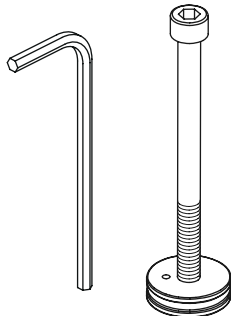

Fig.5 A963377NU seat extractor kit

Instructions for removing the hot cartridge seat

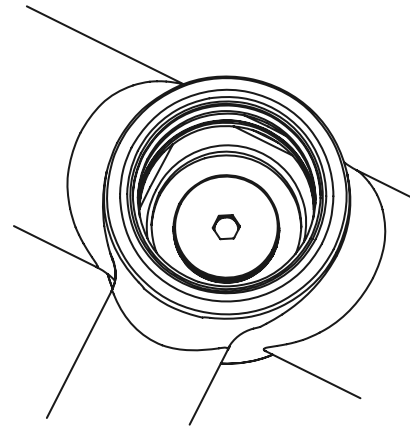

Fig.6 Seat location

First check if a brass seat is fitted in the product. With the thermostatic cartridge removed, the brass seat will be visible at the bottom of the cartridge well. A 6mm hexagonal drive is machined into the centre of the brass seat.

If seat removal is necessary then proceed as follows:

- Obtain the Seat Extraction Kit A963377NU.

- From the Seat Extraction Kit, use the 6mm Allen key and unscrew the brass seat anti-clockwise until almost disengaged. If necessary, use a tube on the short end of the Allen key to increase leverage.

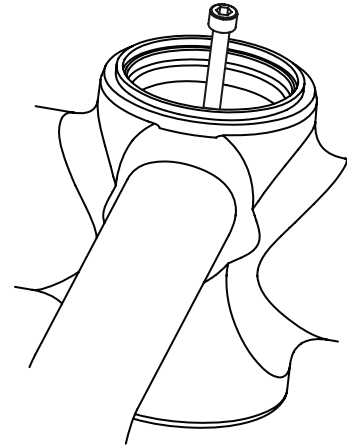

Fig.8 Extract seat

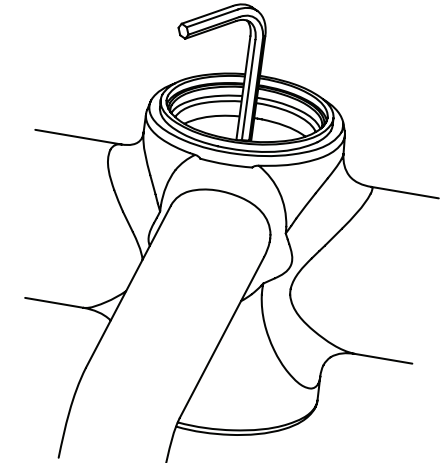

Fig.7 Unscrew seat

- Next, use the extractor tool to lift the seat out of the product.

To do this, push the tool firmly into the bore of the seat, the o-ring on the tool will grip the seat. Turn the tool anti-clockwise to disengage the seat and then lift the seat out gently.

Keep the tool and seat inline with the bores of the product whilst extracting (to prevent jamming).

Fit the spare cartridge A962280NU in accordance to the maintenance instructions mentioned previously. The extracted brass seat is not needed and can be discarded.

RECOMMENDATION:

Once the cartridge has been replaced, use the installation instruction booklet (provided with the product) to carry out the normal checks and commissioning procedures.