

# CHR EFSNK C

## CHERRY Tap Range Cherry EasyFit Monobloc Sink Mixer Chrome



### Specification

Product Type:	Kitchen Taps
Main Construction Material:	Brass
Mount Type:	Deck Mounted
Handle Type:	Single Lever
Connection Inlet:	1/2" BSP Flexible Tails
Connection Outlet:	Open
Number of Tap Holes:	1
Valve/Cartridge Type:	35mm Cartridge
Plumbing System Requirements:	Suitable for all plumbing systems
Minimum Dynamic Pressure (bar):	0.3 bar
Maximum Dynamic Pressure (bar):	5.0 bar
Maximum Hot Water Temperature °C:	65°C
Maximum Static Pressure (bar):	10 bar
Flow Type:	Single Flow
Isolation Included:	Yes

### Features:

- Long life ceramic cartridge for added durability and ease of use
- Metal fixing nut for added durability
- Easyfit base included
- Flexible tails included

### Product Certifications:



WRAS Cert. Number: 2006906  
WRAS Expiry Date: 30/06/2025



For more products, visit our website:  
<http://www.bristan.com>



### Dimensions (measurements in mm)

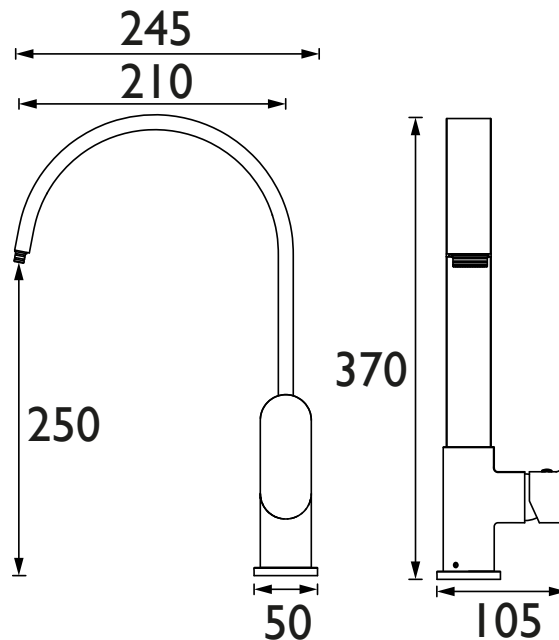

### Flow Rates (l/min)

System Pressure (bar)	0.3	0.5	1	2	3	5
CHR EFSNK C (mixed)	6	7.7	10.9	15.4	18.9	24.4

## TECHNICAL DATA SHEET



# BRISTAN