

BRISTAN

TAPS & SHOWERS

Installation Instructions & User Guide

Please leave these instructions with the end user

Product Code: GLL PROSNK C (D1)

Specifications

Dynamic Water Pressure

Min: 1.5 bar Max: 5.0 bar



Maximum Static Pressure: 10.0 bar

Inlet Water Temperature

Cold Water Supply

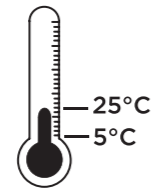

Min: 5°C Max: 25°C

Hot Water Supply

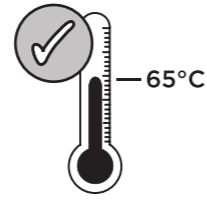

65°C Recommended

Inlet Connections



Marked red for hot and blue for cold

1/2" BSP Flexible Tails

Tools You'll Need



Adjustable Spanner

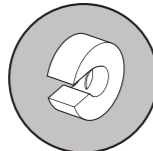

Pipe Cutter

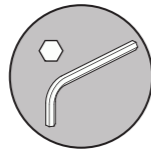

Hexagonal Key

Servicing Your Tap

We recommend servicing your tap at least once every year to prolong its life. To see a video showing how to remove the cartridge for servicing, scan the QR code with your smart phone or tablet.



Alternatively visit www.bristan.com/howto

Prior to Installation

All products manufactured and supplied by Bristan are safe provided they are installed, used correctly and receive regular maintenance in accordance with these instructions.

This product has been tested to the Water Regulations Advisory Scheme (WRAS) and satisfies the requirements of the Water Supply (Water Fittings) Regulations 1999 and current bylaws. For full Installation Requirements & Notes (IRN) please visit www.bristan.com/directory.

Isolation valves must be fitted to the inlet water supplies to ensure ease of future maintenance.

Before installing these taps the water supply must be thoroughly flushed in order to remove any swarf, solder etc.

This product must not be modified in any way as this will invalidate the guarantee.

Pack Contents

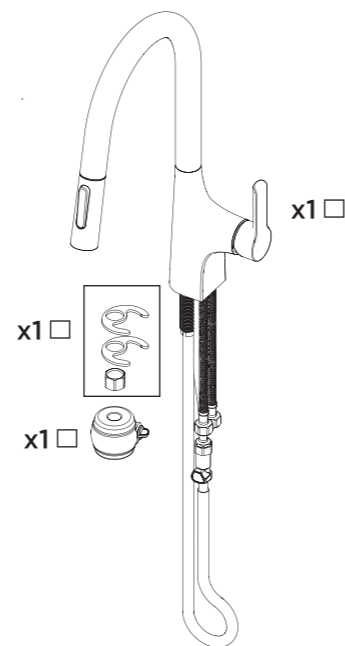

x1 Tap Body

x1 Hose

x1 Flexible Tail

Flexible Connecting Pipes

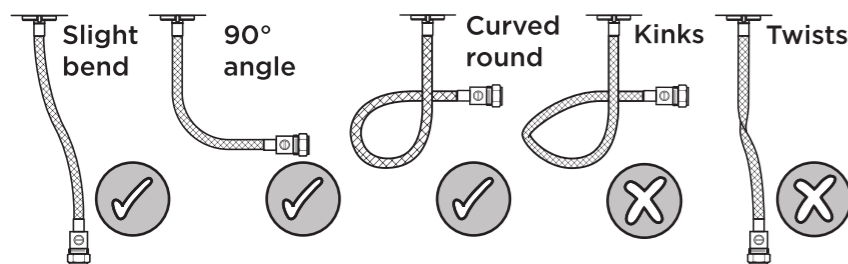

Spare Parts

To replace any spare parts for your tap, why not scan the QR Code or visit www.bristan.com and search for your product.



Warning from Your Water Supplier

It could be a criminal offence to use this tap with a mains water supply drawn directly from the supply pipe (the supply pipe is the one that brings the water supply into your home and is directly connected to the public water main).

This tap has an outlet on a flexible hose, which if immersed in water, could result in contaminated water being back drawn into the pipework if the supply pressure dropped. To prevent contamination of drinking water in the premises and in the water main, and to comply with the legal requirement of the UK plumbing regulations and byelaws, both hot and cold water supplies to this tap must come from a storage cistern.

If the distributing pipes feeding this tap from the storage cistern have other outlets connected to them, the outlet of this tap must be lower than any of those other outlets.

If installed as a tap which is used for drawing water for drinking, and the quality of the water from the storage cistern does not meet the standards for drinking water, a separate tap supplied with wholesome water must be provided for drinking purposes.

For further information, contact the Water Regulations Department of your Local Water Supplier (see WRAS website: www.wras.co.uk) or contact the Water Regulations Advisory Scheme by email (info@wras.co.uk) or telephone: 0333 207 9030

Installation

1

Feed the pipes through the sink hole and place the tap body.

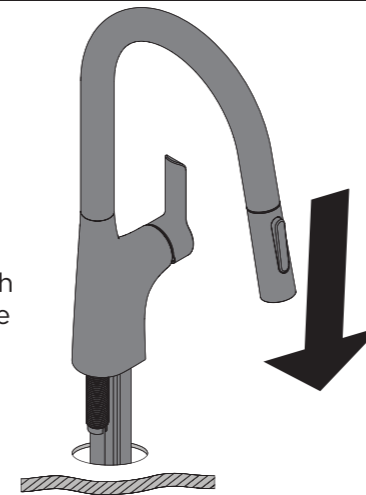

2

Push the washers against the tap body and tighten with the fixing nut.

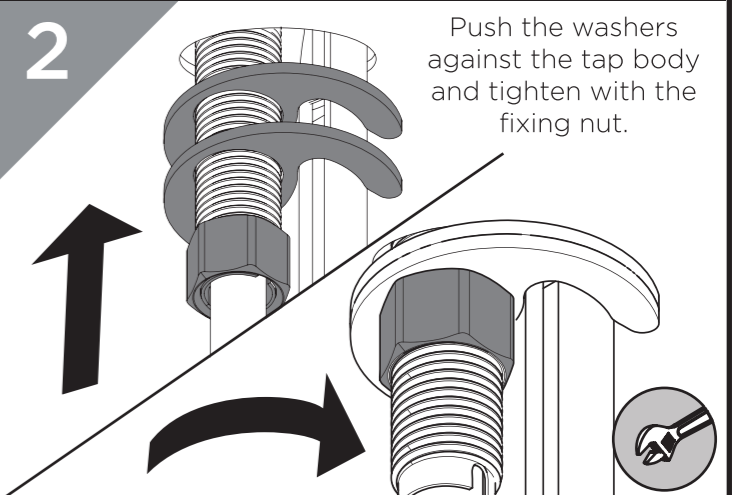

3

Feed the hose weight on to the hose.

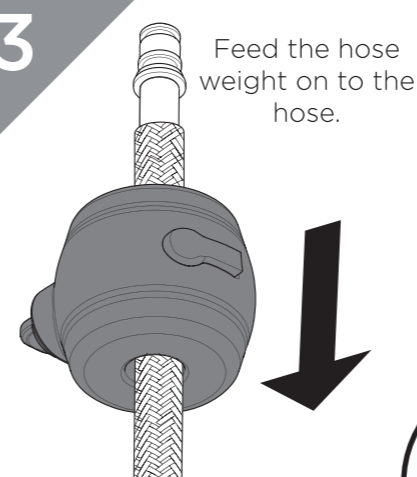

4

Attach the hose to the mixed pipe outlet.

REMEMBER hot on the left, cold on the right

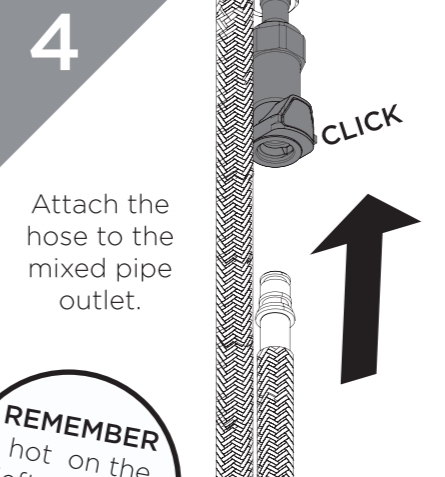

5

Move hose weight down as shown and tighten in place.

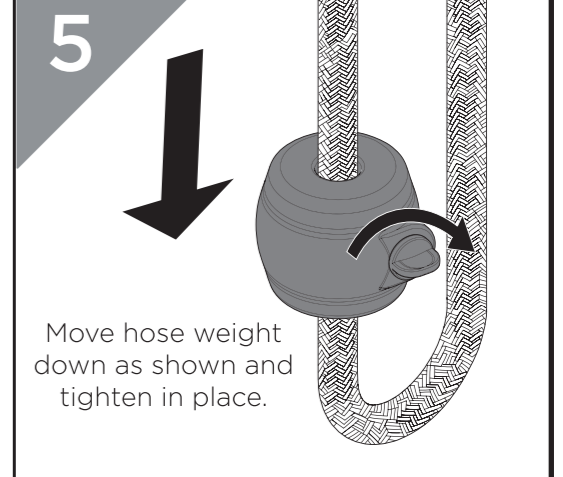

6



IMPORTANT fit isolation valves for future maintenance



Connect the hot and cold water connections.

Olive

Compression Nut

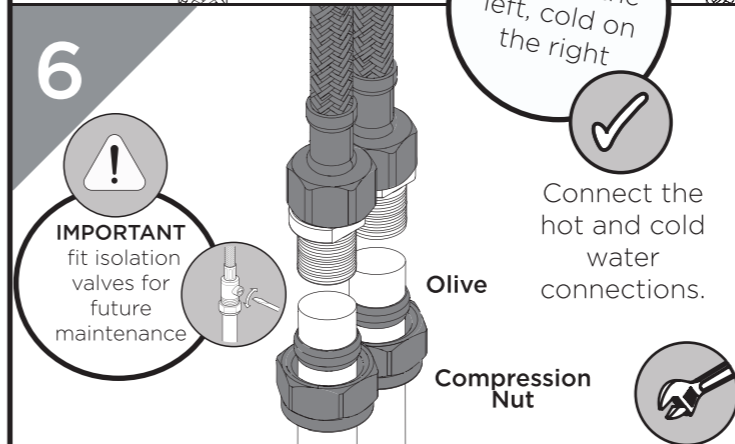

7

Switch on the water supply and check connections for any leaks.



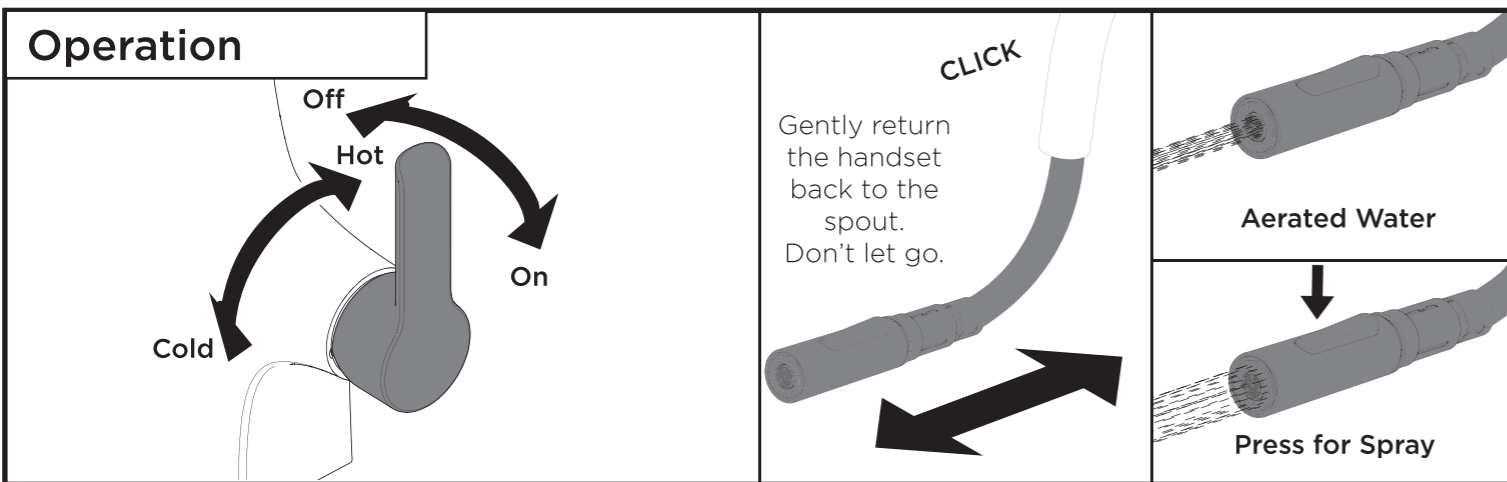

General Cleaning

Your fitting has a high quality finish and should be treated with care to preserve the visible surfaces.

All surfaces will wear if not cleaned correctly, the only safe way to clean your mixer tap is to wipe with a soft damp cloth. Stains can be removed using washing up liquid. All bath cleaning powders and liquids will damage the surface of your fitting, even the non-scratch cleaners.

Note: Never use abrasive detergents or disinfectants or those containing alcohol, hydrochloric acid or phosphoric acid.

Maintenance - Cleaning/Replacing Cartridge

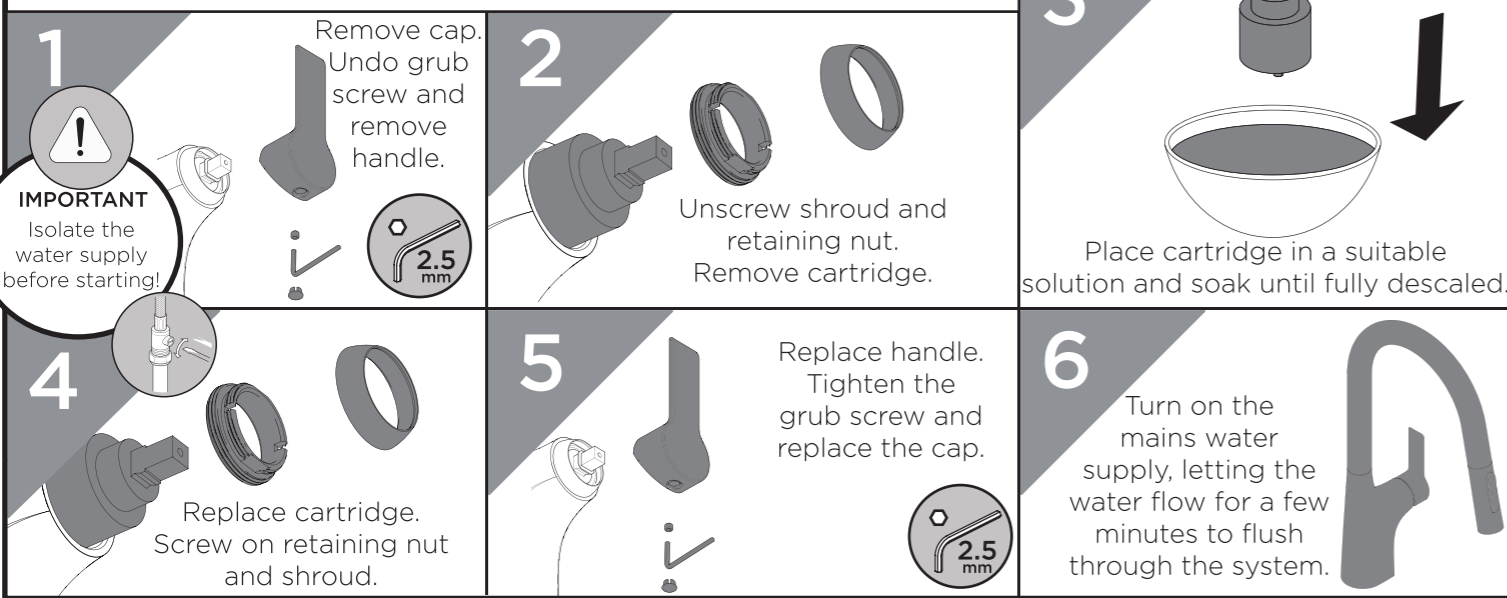

Maintenance - Replacing Handset



Troubleshooting

Symptom	Cause(s)	Remedy
No flow or low flow rate	Partially closed isolation valve.	Open isolation valve.
	Instantaneous water heater cycles on and off as flow rate or pressure is too low.	Increase water flow rate or pressure through system.
	Head of water is below the minimum distance required.	Check the site has the required working pressures according to the specification.
	Hot or cold water being drawn off elsewhere causing pressure changes or instantaneous boiler temperature changes.	Do not use other water outlets when using the taps.
	Airlock or partial blockage in the supply pipework or hoses.	Flush through pipework to ensure removal of debris and any airlocks.
	Water supply failure	Investigate water supply. Check your plumbing and heating systems for any faults.
Water dripping from taps	Hose is leaking due to aging/damaged O-Rings or Anti-Friction seals	Call Customer Services for replacement seals
	This is normal for a short time after using the taps.	This is caused by capillary action, the build up of water in the tap body.
Taps do not turn on	If water continues to drip, possibly due to the ceramic disc valves/cartridge	Remove valves/cartridge and clean, refer to 'Maintenance' section before starting any maintenance.
	Closed isolation valve.	Open isolation valve.
Hose doesn't release/return properly	Mains water supply turned off.	Turn on mains water supply.
	Hose is blocked/kinked/twisted or snagged on other objects.	Isolate the water supply and check the hose for any blockages or defects. Ensure the area is clear so the hose can't get snagged on other objects.
Handset Pressure Changes	Site water pressure is too high for the working pressures listed on the specification.	Install a Pressure Reducing Valve in order to achieve working levels of pressure.

Notes

Please use this space for any notes you or your installer may have regarding the installation/plumbing of this product.

At Bristan, we want to make things as easy as possible for our customers. That's why we offer solid guarantees on all our products, effective from the date of purchase, to give you peace of mind.

To start your free guarantee simply scan the QR code and register your product. Alternatively visit www.bristan.com/register.

For any other queries, please call our Customer Service on 0330 026 6273 where our expert team of advisors will be able to offer you any help and advice.

For full guarantee terms and conditions visit www.bristan.com/guarantees.



We Know & We Care