

CUSTOMER SERVICE

Guarantee

This product is guaranteed against both faulty materials and manufacturing process for a period of one year from date of purchase, provided that the product has been installed correctly and used in accordance with the instructions in this manual.

Any part found to be defective during the guarantee period will be replaced or repaired - at our option - without charge, provided that the product has been properly used and maintained.

Routine cleaning and maintenance should be carried out in accordance with instructions supplied.

The product should not be modified or dismantled except by a person authorised by Kohler Mira Ltd. Your statutory rights are not affected by this guarantee.

Customer Service Policy

If within the guarantee period the product does not function correctly, first check the fault finding analysis in the manual to see if the difficulty can be resolved.

Failing this, please contact your installer to check that the product has been installed and commissioned in accordance with this manual.

If the fault can not be resolved, please contact the Customer Service Department who will try to assist, or will arrange a local Service Engineer or Agent to call and arrange a visit.

Within the guarantee period there will be no charge for parts or labour if the fault concerned is due to the product. However, the guarantee does not cover difficulties due to incorrect installation or misuse.

During the service visit yourself or a responsible person should be present at all times. If the Service Engineer or Agent can not gain access at the prearranged time a callout charge may be made.

Payment for the Service visit, if applicable, should be made direct to Service Engineer or Agent using Access, Visa or cheque supported by a banker's card.

Spare Parts

Functional spare parts are available for your products maintenance. Items can be identified from spares drawing inside manual, please contact Customer Service to confirm spare and details of a spares stockist for your area. Your product serial number or date mark (if available) may be useful to identify parts.

Meynell Valves
Cromwell Road
Cheltenham
Gloucestershire
GL52 5EP
Tel: 0870 2410888
Fax: 01242 282595

Meynell is a registered trade mark of
Kohler Mira Ltd.

The company reserve the right to alter
product specifications without notice.



BS EN ISO 9001 : 1994
Reg. No. FM 14648

 **Meynell**

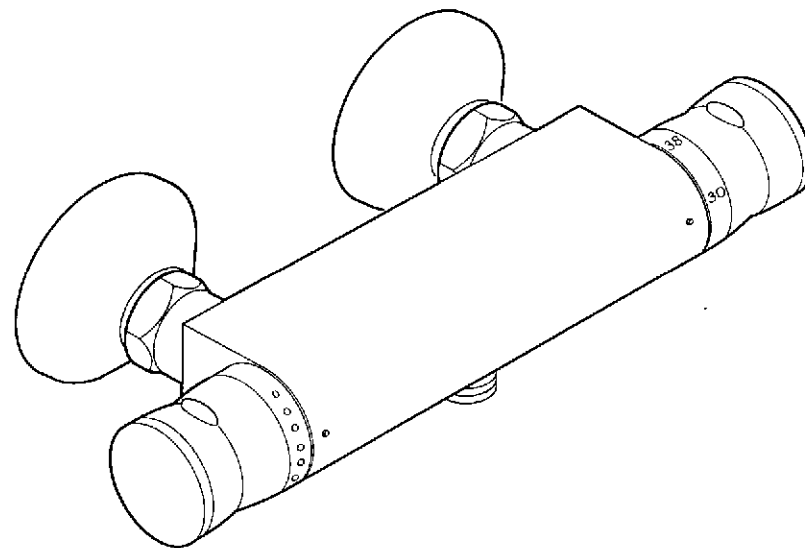

V4

THERMOSTATIC SHOWER VALVE PRODUCT MANUAL

INSTALLER

Please leave manual with user for future
reference to unit operation and maintenance.

CONTENTS

Contents	2
Introduction	3
Pack Contents Checklist.....	4
Dimensions	5
Specifications	6
Installation Requirements.....	8
Installation	11
Commissioning	13
Setting the Maximum Temperature	13
Setting the Flow Level	15
Operation.....	16
Fault Finder	17
Maintenance.....	18
Cleaning	18
Maintaining the Non-Return Valves	19
Thermostatic Cartridge Renewal	20
Flow Cartridge Renewal	22
Spare Parts	24
Accessories	24
Customer Service	28

INTRODUCTION

Description

The V4 Thermostatic Shower Valve provides accurate temperature control and flow rates for a shower unit.

Safety Warnings

This V4 Thermostatic Shower Valve is precision engineered and should give continued safe and controlled performance, provided:

1. It is installed, commissioned, operated and maintained in accordance with manufacturers recommendations.
2. Periodic attention is given, when necessary, to maintain the product in good functional order.

The function of a thermostatic mixing valve is to deliver water consistently at a safe temperature. In keeping with every other mechanism, it cannot be considered as functionally infallible and as such, cannot totally replace a supervisor's vigilance where that is necessary. Provided it is installed, commissioned, operated and maintained within manufacturers recommendations, the risk of failure, if not eliminated, is reduced to the minimum achievable.

PACK CONTENTS CHECKLIST

V4 Thermostatic Shower Valve

It is recommended that you check that the contents of the box are complete before you begin the installation.

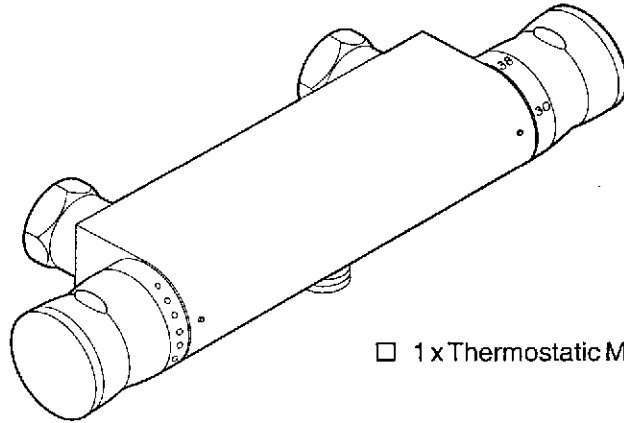

1 x Thermostatic Mixer

2 x Inlet Connectors

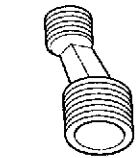

2 x Concealing Plates

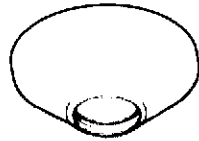

2 x Sealing Washers

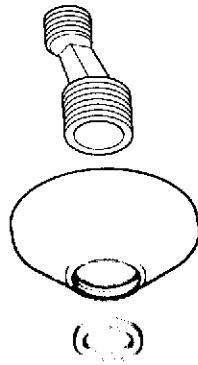

DIMENSIONS

V4 Thermostatic Shower Valve

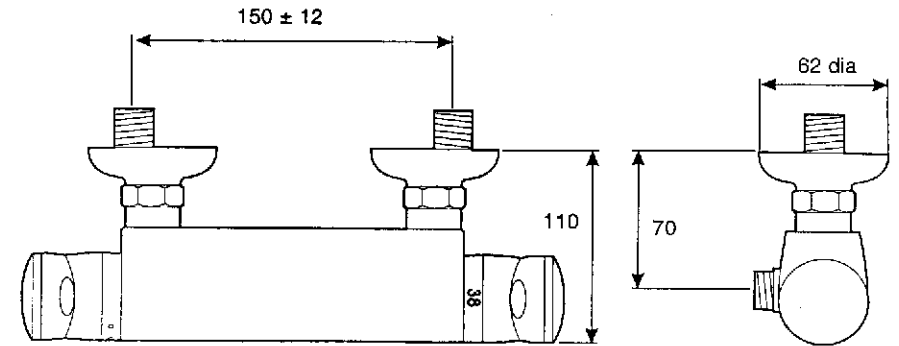

All dimensions are nominal and in millimeters.

SPECIFICATIONS

Notes

1. The installation, commissioning and maintenance must be carried out in accordance with instructions supplied by the manufacturer, and be installed by qualified or competent persons.
2. Installations must comply with the requirements of UK Water Regulations/Bye-laws (Scotland), Building Regulations or any particular regulations and practices, specified by the local water supplier.

Temperature Control

The following temperature specifications produce optimum control:

- Minimum temperature differential between hot supply and outlet temperature: **10°C**
- Optimum temperature control range of mixer: **20–50°C**
- Minimum hot water supply temperature: **55°C**
- Maximum hot water supply temperature: **90°C**

Note! For safety, a recommended hot water storage temperature maintained below 80 °C and for ablutionary installations at between 60 to 65 °C.

The performance specification outlined below is achieved with mixer outlet blend temperature set between 35–45°C and supplies of 15°C cold and 65°C hot with nominally **equal** pressures.

- Outlet blend temperature is maintained within 2°C with a 10°C change in hot or cold supply.
- Thermostatic shut down to seepage within 5 seconds if cold supply fails. This is achieved only if the hot supply temperature is 10°C above the set outlet blend temperature.

Pressures

The following pressure specifications produce optimum control:

- Maintained supply pressures should be nominally **equal**.
- Maximum Pressure Loss Ratio: **5:1**
- Minimum Maintained Pressure: **0.5 bar**.
- Maximum Maintained Pressure: **5 bar**.
- Maximum Static Pressure: **10 bar**.

Flow Rates

Note! No shower kit attached.

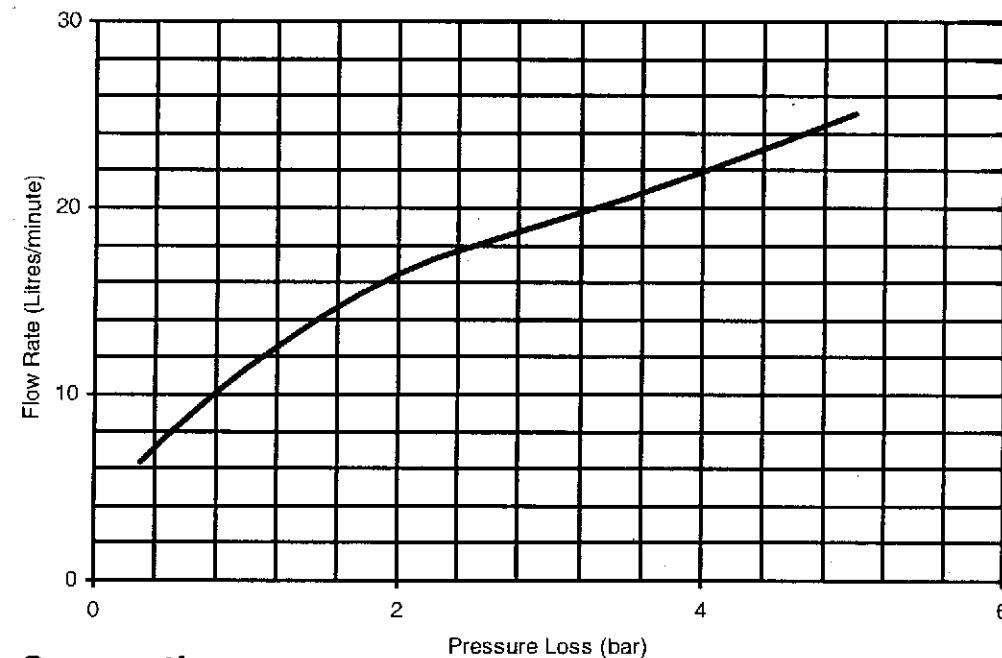

Connections

Offset connector:

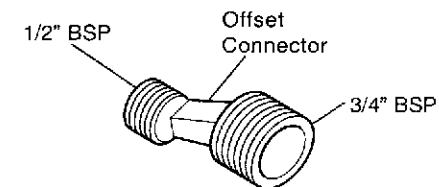

INSTALLATION REQUIREMENTS

Key to Symbols

- ⊗ Isolating Valves
- ⊙ Mixing Valve
- ⌒ Overflow Indicator
- ⋈ Pressure Reducing Valve
- ⊗ Twin Impeller Pump
- ⊙ Single Impeller Pump
- ⊗ Tempering Valve
- ⊙ Mini Expansion Vessel

Gravity-Fed System

The shower **MUST** be fed from a cold water cistern and a hot water cylinder providing nominally equal pressures.

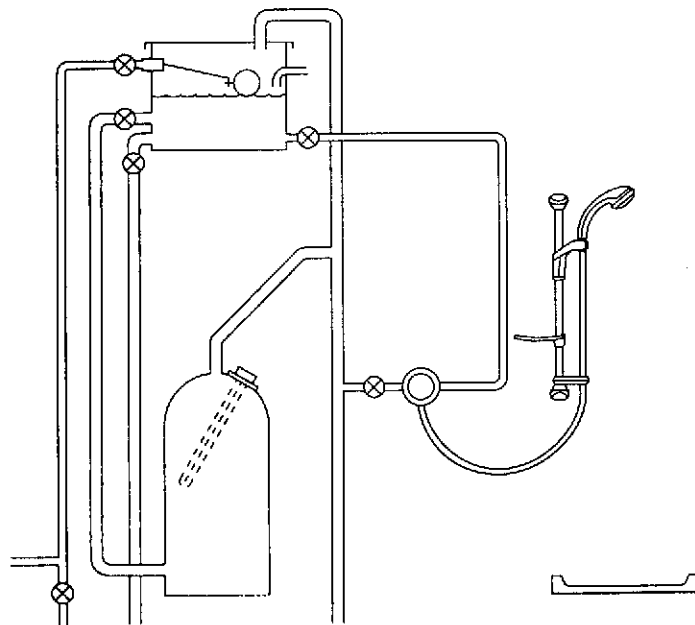

8

Gas-Heated System

The shower **MUST** be installed with a gas water heater or combination boiler of a **fully modulating** design. A fully modulating boiler is one where the draw-off rate is indirectly controlling the gas flow to the boiler, producing an relatively constant hot water temperature.

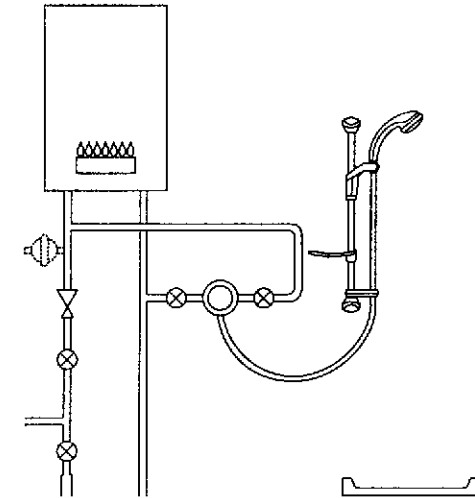

Unvented Mains Pressure System

The shower can be installed with an unvented, stored hot water cylinder. Only "a competent person" as defined by the Building Regulations may fit this type of system.

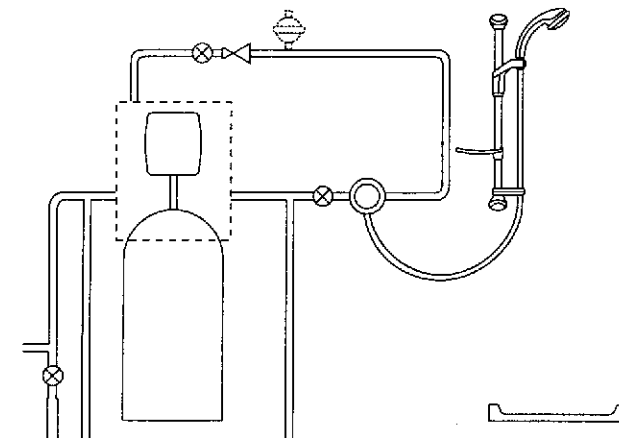

9

Mains Pressurised Instantaneous Hot Water System

The shower installed with systems of this type is supplied with hot water through a tempering valve, which provides relatively constant hot water, and the shower compensates for temperature changes if they occur.

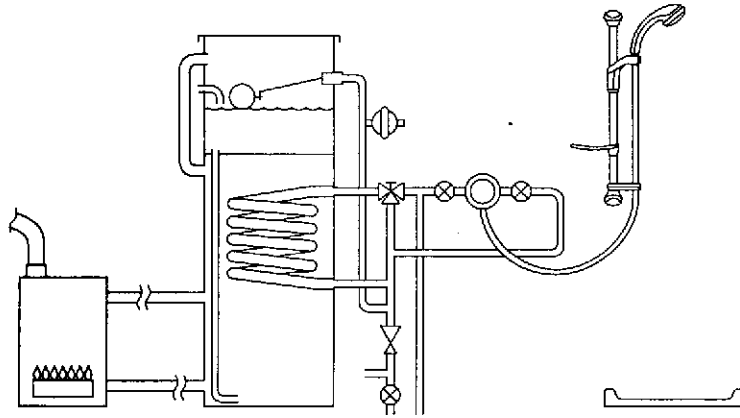

Pumped System

The shower can be installed with an inlet pump (twin impeller). The pump must be installed on the floor next to the hot water cylinder. Ensure that the hot water cylinder vent pipe is arranged as shown to enable air separation.

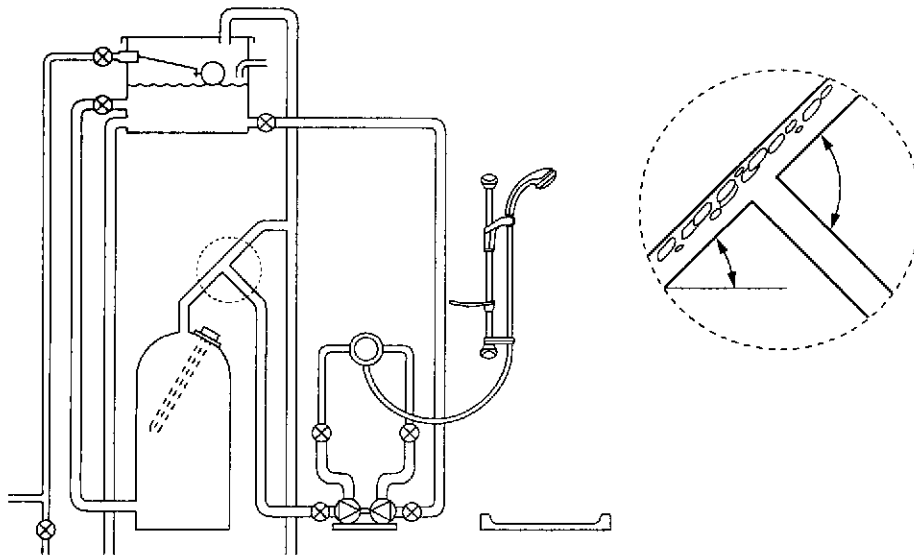

INSTALLATION

General

1. The installation, commissioning and maintenance must be carried out according to instructions supplied, and must be conducted by qualified or competent person.
2. Before starting installation, ensure that all site requirements correspond to information given in the **SPECIFICATION** section.
3. **DO NOT** install product in a position where it could become frozen.
4. Install in a position with easy access for maintenance.
5. Accessible isolating valves **MUST** be provided for maintenance.
6. The supply pipework **MUST** be thoroughly flushed to remove any debris before connection.
7. The hot water supply must be connected to left inlet (next to the flow selector).
8. Installations must comply with the requirements of UK Water Regulations/Bye-laws (Scotland), Building Regulations or any particular regulations and practices, specified by the local water supplier.
9. No form of outlet flow control should be fitted. Only use shower fittings recommended by the manufacturer/supplier.

Installation

CAUTION! The shower valve is heavy. Ensure that it has sufficient support when you are installing it on a stud partition or laminated panel wall.

NOTE! For installation on a stud partition or laminated panel wall, a mounting bracket is available as an accessory to help support the product. The mounting bracket is available for rear-entry pipework only (see the **SPARE PARTS: Accessories** section).

1. Attach the connectors to the pipework in the wall using the thermostatic mixer as a guide to spacing.
2. Screw the concealing plates onto the connectors until they come into contact with the wall.

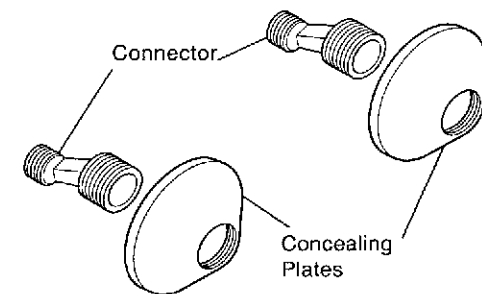

CAUTION! Ensure supply pipework is flushed through.

3. Assemble the thermostatic mixer with a filter and a sealing washer in each inlet and attach to the connectors.
4. Tighten the joints using a 20 mm spanner.
5. Make connections to mixer outlet.
6. Check for leaks at all pipe connections.

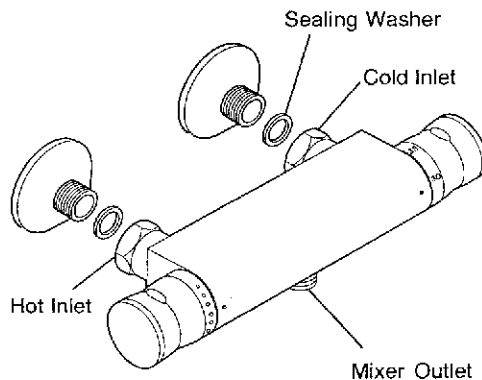

COMMISSIONING

Setting the Maximum Temperature

The V4 Thermostatic Mixer has been preset to approximately 38°C at the factory, which is appropriate for most systems. However, it is possible that the temperature of the water flowing through the shower outlet is not exactly the same as the temperature that is indicated on the temperature selector knob. In this case, you may choose to adjust the setting.

CAUTION! Before testing the mixer, ensure that the hot and cold water are flowing correctly by exercising the temperature selector knob between the cold and hot stops.

1. Turn the temperature selector knob to position **38** and test that the temperature of the water from the shower outlet is between 36°C and 38°C (as measured with a bath thermometer). If the water is not in this range of temperatures, proceed with the following procedure.
2. Turn the temperature selector knob to the fully cold position.
3. Hold down the temperature override button and slowly turn the knob until the output water reaches a temperature of 38°C.
4. Wait for the water temperature to stabilise.

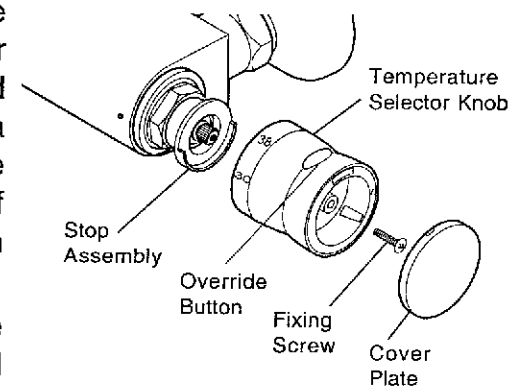

5. Insert a small screwdriver into the notch and pry off the cover plate.
6. Unscrew the fixing screw.
7. Remove the temperature selector knob without disturbing the stop assembly.
8. Replace the temperature selector knob so that the **38** mark is level with the reference mark on the body of the mixer valve.
9. Replace the fixing screw and the cover plate.

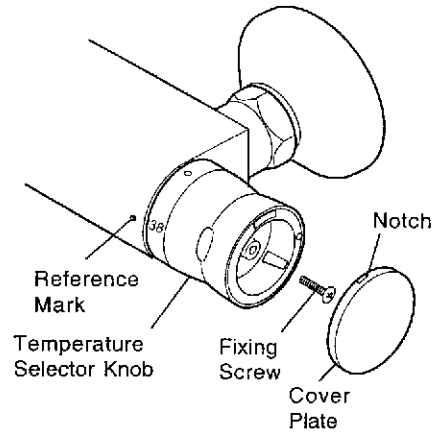

Setting the Flow Level

If the preset flow level is not appropriate, you may choose to adjust it. For example, you may choose to lower the flow level to save water.

1. Turn the flow selector knob to the **OFF** position.
2. Slowly turn the flow selector until the desired flow is achieved. Press down the flow override button if necessary.
3. Insert a small screwdriver into the notch and pry off the cover plate.
4. Unscrew the fixing screw.
5. Remove the flow selector knob without disturbing the stop assembly.
6. Replace the flow selector knob so that the flow override button is just to the right of the fixed stop on the stop assembly.
7. Replace the fixing screw and the cover plate.

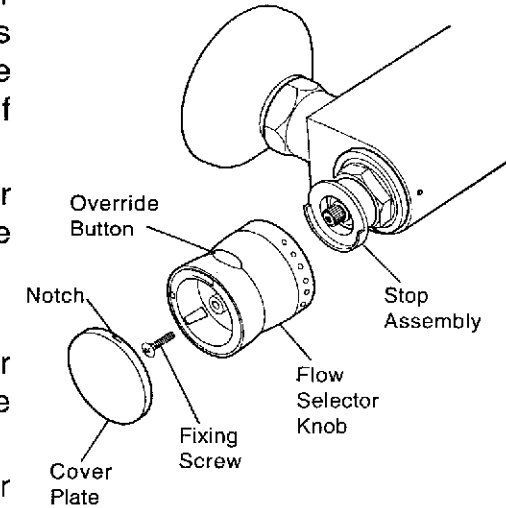

OPERATION

Adjusting the Temperature

The temperature is controlled by rotating the temperature selector knob.

For safety reasons, the temperature is limited by a stop. To obtain a higher temperature, press the override button on the temperature selector knob and continue to rotate the knob.

Adjusting the Flow

The flow is controlled by rotating the flow selector knob.

For water economy reasons, the flow is limited by a stop. To obtain a higher flow, press the override button on the flow selector knob and continue to rotate the knob.

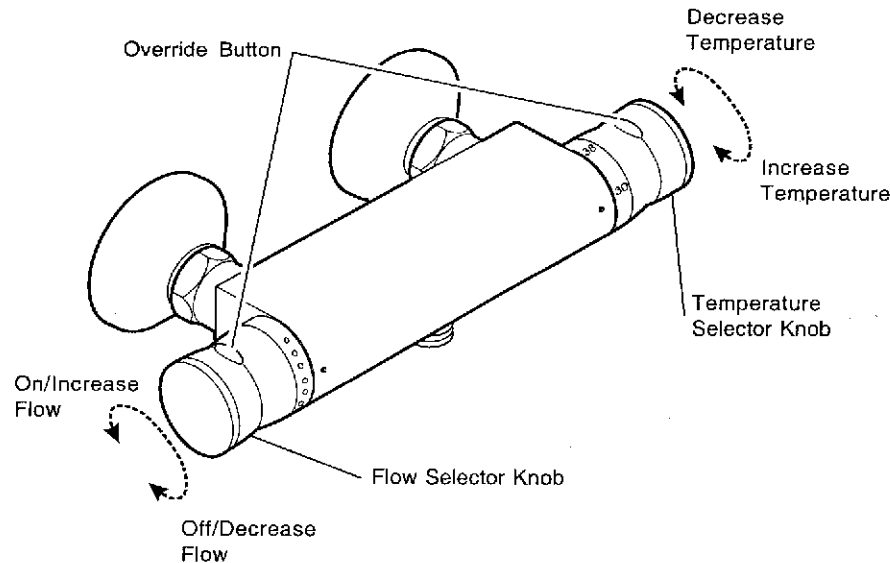

FAULT FINDER

Symptom	Cause/Rectification
1. Only hot or cold water from mixer outlet.	<ul style="list-style-type: none"> a. Inlets reversed (hot supply to cold supply). b. No hot water reaching mixer. c. Check filters for blockage. d. Installation conditions continuously outside operating parameters: refer to the SPECIFICATION and the COMMISSIONING sections.
2. Fluctuating or reduced flow rate.	<ul style="list-style-type: none"> a. Check filters for blockage. b. Make sure minimum flow rate is sufficient for supply conditions. c. Make sure the maintained inlet pressures are nominally balanced and sufficient. d. Make sure the inlet temperature differentials are sufficient. e. Check thermostatic performance. f. Flow regulators fitted incorrectly. g. Airlock or partial blockage in pipework.
3. No flow rate from mixer outlet.	<ul style="list-style-type: none"> a. Check filters for blockage. b. Check fittings for blockage. c. Hot or cold supply failure.
4. Blend temperature drift.	<ul style="list-style-type: none"> a. Refer to symptom 2. above. b. Hot or cold supply temperature fluctuation. c. Supply pressures fluctuating. d. Seal damage or wear. Renew seals.
5. Maximum blend temperature setting too hot or too cold.	<ul style="list-style-type: none"> a. Indicates incorrect maximum temperature setting; refer to the COMMISSIONING section. b. Refer to symptom 4. above.
6. Flow rate too low or too high.	<ul style="list-style-type: none"> a. (Too low) Insufficient supply pressures (refer to the SPECIFICATIONS: Pressures section). b. (Too low) Refer to symptom 2. above. c. (Too high) Supply pressure too high (refer to the SPECIFICATIONS: Pressures section). d. (Too high) Refer to symptom 2. above.

MAINTENANCE

General

This Product is precision engineered and should give continued safe and controlled performance, provided:

1. It is installed, commissioned, operated and maintained in accordance with manufacturers recommendations.
2. Periodic attention is given, when necessary, to maintain the product in good functional order.

The exploded view and parts list illustrates the assembly of the product.

You may, if you wish, choose to engage a service engineer. The terms are outlined on the back page.

Lubricants

Standard silicone-only based lubricants may be used to assist refitting.

WARNING! Use silicone-only based lubricants. Do not use oil-based or other lubricant types as rapid deterioration of seals may occur.

Cleaning

The V4 should be cleaned using a mild washing up detergent or soap solution, rinsed and then wiped dry with a soft cloth.

WARNING! Many household cleaners contain abrasive and chemical substances, and should not be used for cleaning plated or plastic fittings.

Maintaining the Non-Return Valves

The non-return valves are located in the valve body, and are accessible through the inlet connectors.

CAUTION! Ensure that the non-return valves are installed correctly to prevent crossflow or malfunction of the valve.

1. With the water supplies turned off and the thermostatic mixer removed, remove the fibre washer, the circlip and the filter.
2. Remove the non-return valve and clean any debris.
3. On reassembly ensure that the non-return valve is fitted the correct way round (with the arrow indicating the flow pointing towards the mixer).

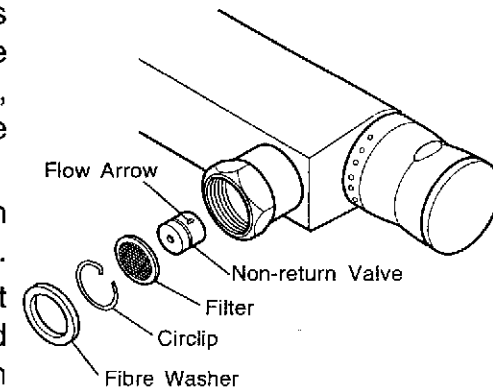

Filter

The inlet filters are located in the inlet connector. Clean or renew as necessary.

Thermostatic Cartridge

In hard water areas the filters in the thermostatic cartridge may become blocked with limescale, which will reduce the flow of water. It is recommended that the cartridges are checked regularly and cleaned in a descaling solution (such as kettle descalent) if necessary. Be sure to follow the manufacturer's instructions on the descalent package. Refer to the **MAINTENANCE: Changing the Thermostatic Cartridge** section.

Note! The cartridge is non-servicable and will require replacement should failure occur.

Thermostatic Cartridge Renewal

Removing the Thermostatic Cartridge

1. Shut off both the hot and cold water supplies to the thermostatic mixer.
2. Turn the temperature selector knob to the maximum temperature position.
3. Insert a small screwdriver into the notch and pry off the cover plate.
4. Unscrew the fixing screw and pull off the temperature selector knob.
5. Remove the stop assembly and the ring.
6. Unscrew the head nut with a suitable spanner.
7. Pull out the thermostatic cartridge.

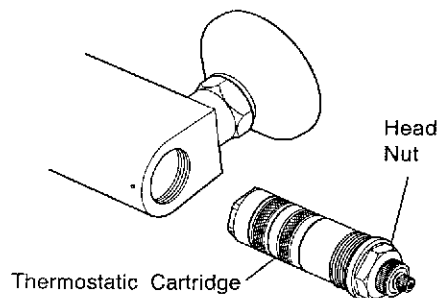
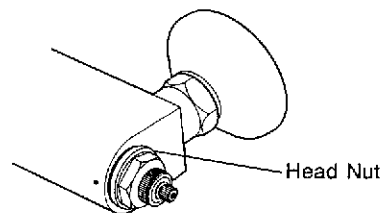
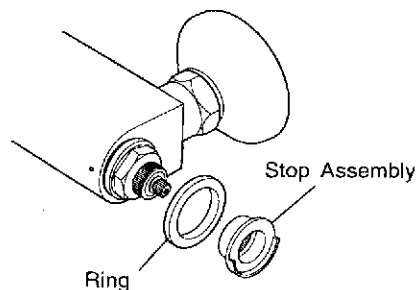
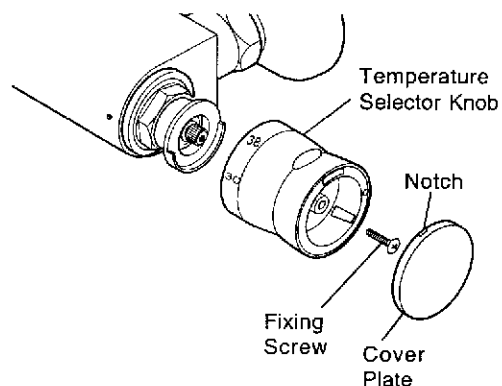

Replacing the Thermostatic Cartridge

1. Place the thermostatic cartridge into the body and tighten the head nut.
2. Fit the ring.
3. Turn on the water supplies.
4. Temporarily fit the temperature selector knob and turn to the fully cold position.
5. Slowly turn the temperature selector knob until the water from the shower outlet reaches a temperature of 38°C.
6. Allow the water temperature to stabilise.
7. Fit the stop assembly so that the reference mark on the mixer body lines up with the stop on the stop assembly.
8. Refit the temperature selector knob with the 38 mark lined up with the reference mark on the mixer body.
9. Fit the fixing screw and the cover plate.
10. The temperature knob should turn through to approximately 38°C to the stop. Operation of the override button will allow further rotation and increase the temperature.

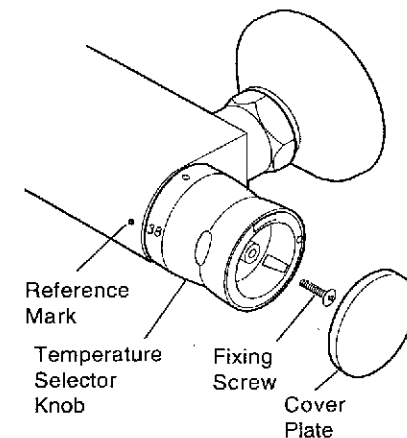
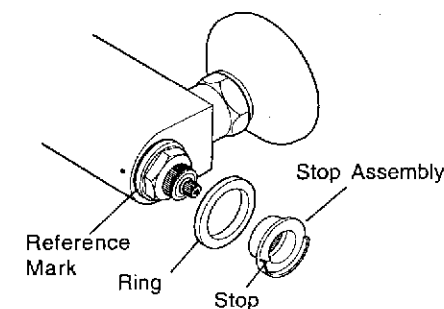
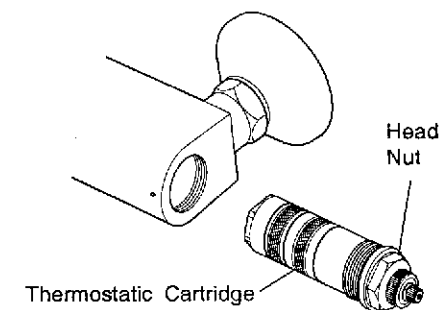

Flow Cartridge Renewal

Removing the Flow Cartridge

1. Shut off both the hot and cold water supplies to the thermostatic mixer.
2. Turn the flow selector knob to the maximum flow position to release any pressure.
3. Insert a small screwdriver into the notch and pry off the cover plate.
4. Unscrew the fixing screw and pull off the flow selector knob.
5. Remove the stop assembly and the ring.

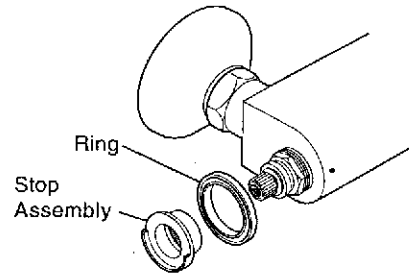
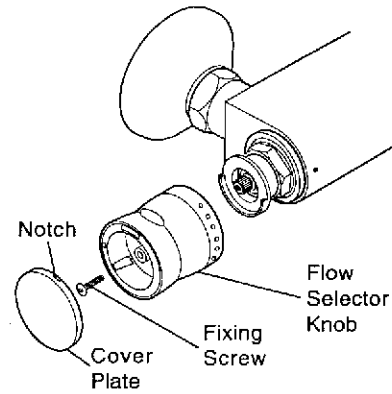

6. Unscrew the head nut with a suitable spanner.

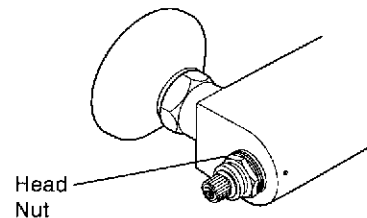

7. Pull out the flow cartridge.

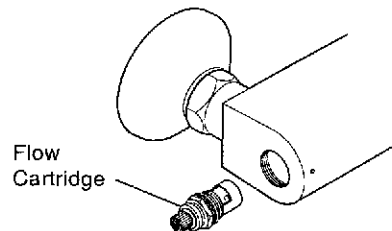

Installing the Flow Cartridge

1. Place the flow cartridge into the body and tighten the head nut.
2. Fit the ring.
3. Temporarily fit the flow selector knob and turn to the fully off position.
4. Turn on the water supplies.
5. Slowly turn the flow selector knob until the water from the shower outlet reaches the maximum flow required.
6. Allow the water flow to stabilise.
7. Fit the stop assembly so that the reference mark on the mixer body lines up with the stop on the stop assembly.
8. Refit the flow selector knob with the fourth largest circle mark lined up with the reference mark on the mixer body.
9. Fit the fixing screw and the cover plate.
10. The flow knob should turn through to the preset maximum. Operation of the override button will allow further rotation and increase the flow.

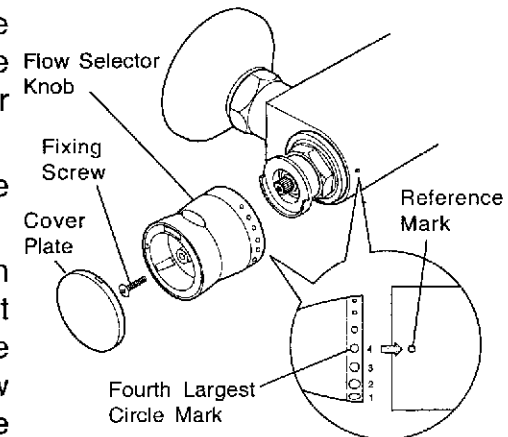
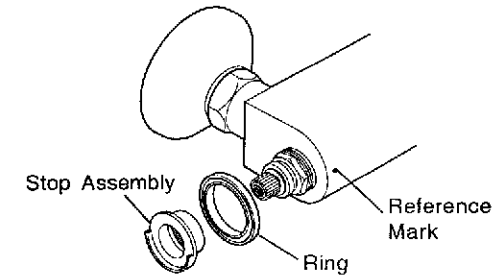
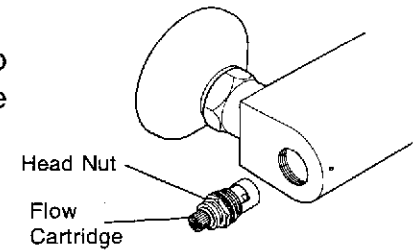

SPARE PARTS

Spare Parts Diagram

Spare Parts List

- 456.01 Offest Connector and Concealing Plate
- 456.02 Filter & Non Return Valve
- 456.03 Flow Cartridge Assembly
- 456.04 Flow Knob Assembly
- 456.05 Temperature Knob Assembly
- 456.06 Thermostatic Cartridge Assembly
- 456.07 Outlet Assembly

Accessories

Available as optional accessories from your Mira stockist.

456.29 Wall Mounting Bracket

Mounting bracket for rear entry pipework installations on a stud partition or laminated panel wall.

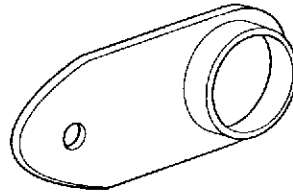

DCV-H Outlet Checkvalve

An outlet double check valve, designed to prevent the backflow or backsiphonage of potentially contaminated water through shower controls that are fitted with a flexible hose as part of the outlet shower fitting. The inclusion of the Mira DCV-H will increase the required supply pressure typically by 0.1 bar.

