

mira

SHOWERS

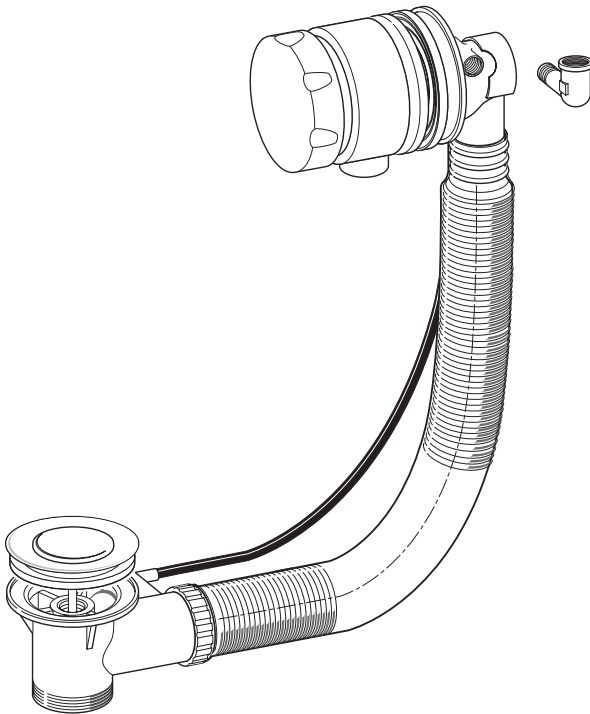

MIRA OVERFLOW

BATH FILLER

Installation and User Guide

These instructions are to be left with the user

INTRODUCTION

The Mira Overflow Bath Filler is a combined bath filler and waste and is suitable for baths from the Kohler range.

The bath filler connects to the outlet connection of a shower valve so that there is no need for a spout.

Suitable for use with high pressure systems only.

PACK CONTENTS

Tick the appropriate boxes to familiarize yourself with the part names and to confirm that the parts are included.

Overflow Bath Filler

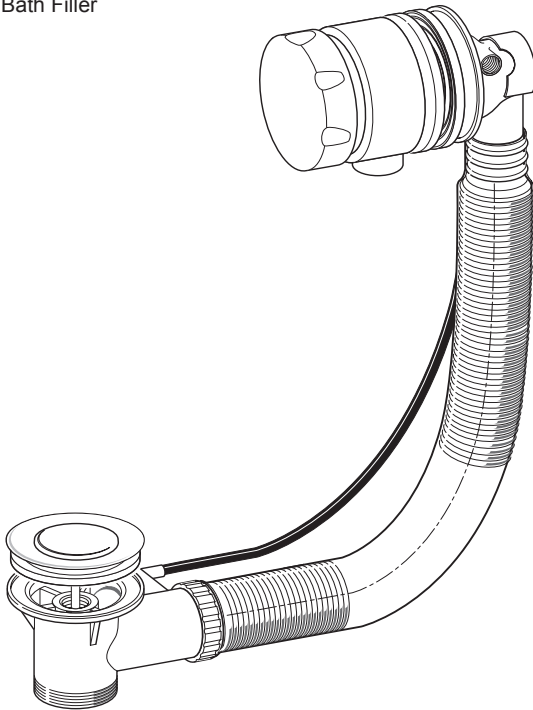

Inlet Elbow

Dimensions

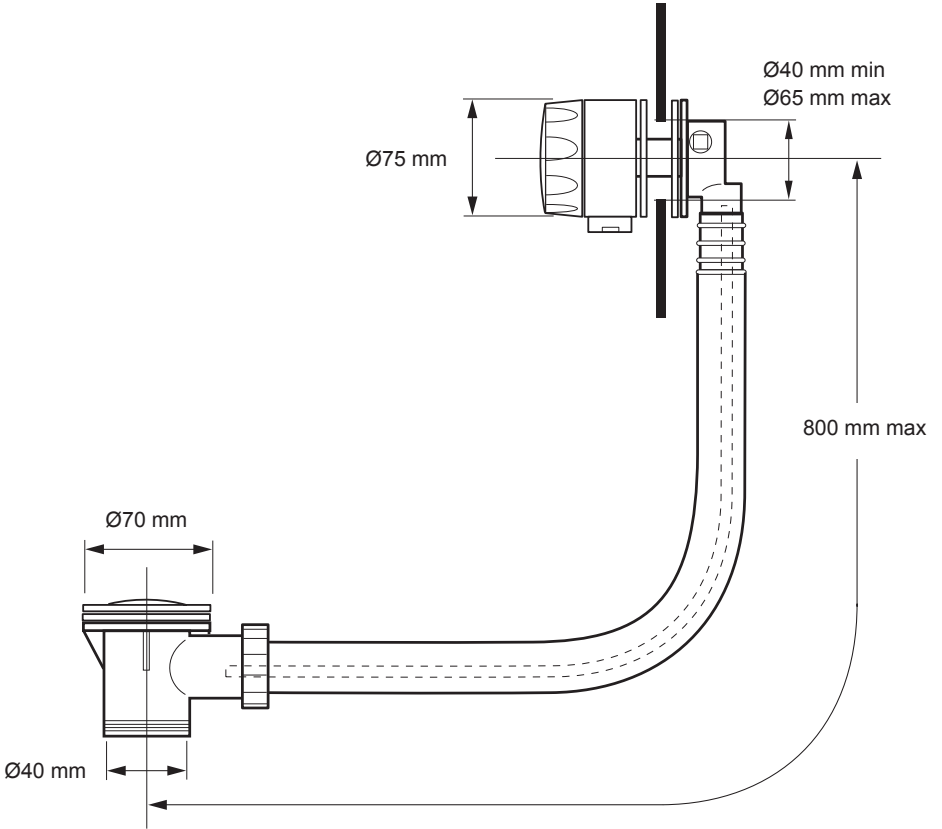

INSTALLATION

1. Turn off the water supply.
2. Apply silicone sealant around the waste body seal and the outlet hole in the bath (in accordance with the manufacturer's instructions).
3. Install the waste body and the waste body seal.
4. Install the waste flange and spacer.
5. Install the waste ferrule and tighten.

Note! Do not overtighten the waste ferrule.

6. Install the plug.

Note! With the operating lever in the down position, ensure the adjusting screw is almost touching the operating lever. Adjustment can be made by turning the adjusting screw.

7. Insert the corrugated end of the overflow pipe into the connection on the waste body, ensuring the fibre washer and conical seal are fitted. Tighten the locking ring securely.

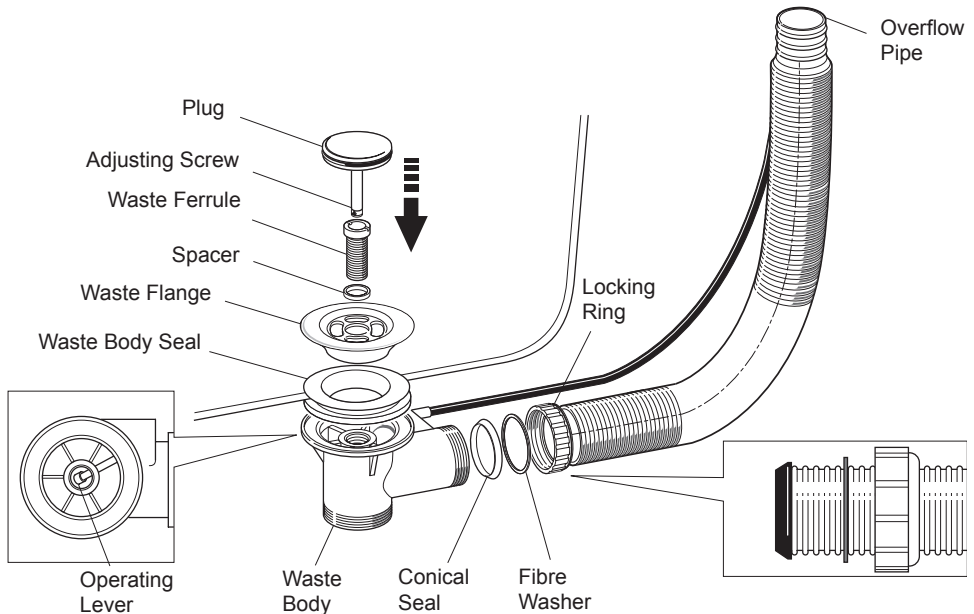

Install the Overflow Bath Filler

1. Push the plain end of the overflow pipe onto the overflow bath filler body (back).
2. Install the inlet elbow into the preferred inlet.
3. Apply PTFE tape or liquid sealant to the blanking plug thread. Do not use oil-based, non-setting jointing compounds.
4. Install the blanking plug to the unused inlet on the overflow bath filler body.
5. Connect the inlet elbow to the shower valve.
6. Install the overflow bath filler (back) and seal A or B, ensure the overflow bath filler is positioned in the centre of the bath overflow hole.

Note! Seal **B** must be used on enamel baths. The seal is embossed with text stating 'FOR S.STEEL TUBS ONLY'

Note! Ensure the operating cable is not bent or kinked, and can move freely.

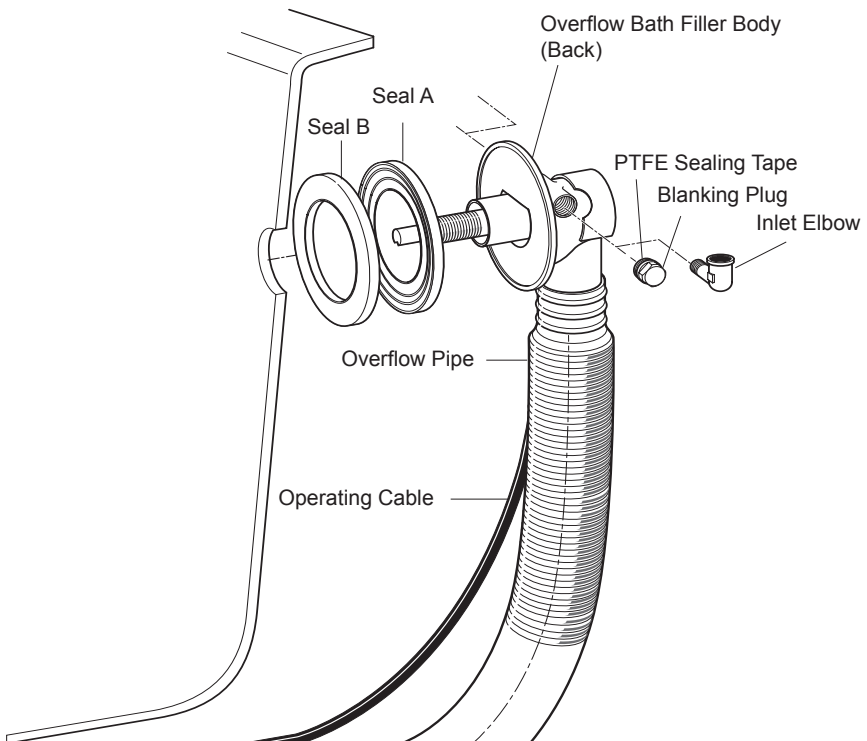

- 6. Install the overflow bath filler body (front) and 'O' seal.
- 7. Install and tighten the ferrule.

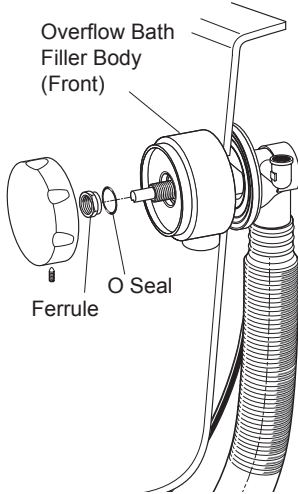

- 8. Turn the control lever so that the operating lever in the waste body is in the closed position.

Note! The operating lever must be in the lowest position to be closed.

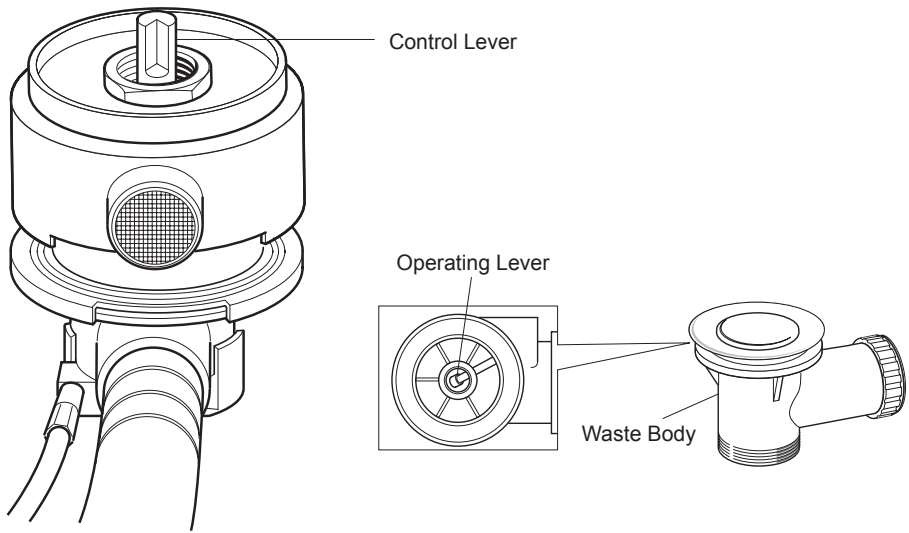

9. Turn the adjusting screw in the plug so that it is almost touching the operating lever.
10. Install the control knob and ensure that the grub screw in the control knob fits into the 'V' notch on the control lever, then tighten the grub screw.
11. Operate the control knob to ensure that the plug 'pops' up sufficiently to allow water to drain from the bath.

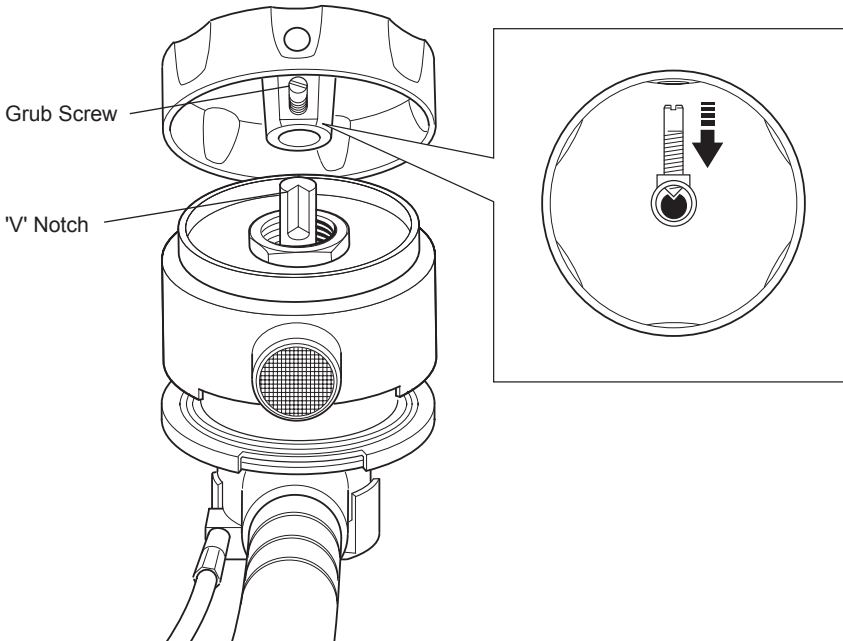

12. Make sure all connections are tight.
13. Turn on the main water supply and check for leaks.

USER MAINTENANCE

Cleaning

Many household cleaners contain abrasive and chemical substances, and should not be used for cleaning plated or plastic fittings.

These finishes should be cleaned with a mild washing up detergent or soap solution, and then wiped dry using a soft cloth.

CUSTOMER SERVICE

Guarantee

Your product has the benefit of our manufacturer's guarantee which starts from the date of purchase.

To activate this guarantee, please return your completed registration card, visit our website or free phone 0800 0731248 within 30 days of purchase (UK only).

Within the guarantee period we will resolve defects in materials or workmanship, free of charge, by repairing or replacing parts or product as we may choose.

If you have not previously activated the guarantee, you will be required to do so prior to the provision of assistance. If you do not activate your guarantee our Engineer will be entitled to charge full payment for the visit (Call out fee plus parts).

This guarantee is in addition to your statutory rights and is subject to the following conditions:

- The product must be installed and maintained in accordance with the instructions given in this user guide.
- Servicing must only be undertaken by us or our appointed representative. **Note!** if a service visit is required the product must be fully installed and connected to services.
- Repair under this guarantee does not extend the original expiry date. The guarantee on any replacement parts or product ends at the original expiry date.
- For shower fittings or consumable items we reserve the right to supply replacement parts only.

The guarantee does not cover:

- Call out charges for non product faults (such as damage or performance issues arising from incorrect installation, improper use, lack of maintenance, build up of limescale, frost damage, corrosion, system debris or blocked filters) or where no fault has been found with the product.
- Water or electrical supply, waste and isolation issues.
- Compensation for loss of use of the product or consequential loss of any kind.
- Damage or defects caused if the product is repaired or modified by persons not authorised by us or our appointed representative.
- Routine maintenance or replacement parts to comply with the requirements of the TMV 2 or TMV 3 healthcare schemes.

What to do if something goes wrong

If your product does not function correctly when you first use it, contact your installer to check that it is installed and commissioned in accordance with the instructions in this manual. Should this not resolve the issue, contact our Customer Services Team who will offer you or your installer advice and if applicable arrange for a Service Technician to call. If the performance of your product declines, check in this manual to see if simple home maintenance is required. If you require further assistance call our Customer Services Team.

Extended Guarantees

A selection of protection plans are available that enable you to cover repair bills for the life of your policy (excludes Eire). Ring 01922 471763 for more details.

Helpdesk Service

Our dedicated Customer Services Team is comprehensively trained and can offer help and advice, spare parts, accessories or a service visit. We will need you to have your model name or number, power rating (if applicable) and date of purchase. As part of our quality and training programme calls may be recorded or monitored.

Mira Showers Website (www.mirashowers.co.uk)

From our website you can register your guarantee, download additional user guides, diagnose faults, purchase our full range of accessories and popular spares, refer to our FAQ's and request a service visit.

Spares and Accessories

We maintain extensive stocks of genuine spares and accessories and aim to provide support throughout the product's expected life. Payment can be made by phone at time of order using most major Credit or Debit cards and we aim to despatch orders within two working days. Items purchased from us are guaranteed for 12 months from date of purchase. For safety reasons spares exposed to mains voltages should only be fitted by competent persons.

Returns – items can be returned within one month of date of purchase, providing that they are in good condition and the packaging is unopened. Please obtain authorisation from our Customer Services Team before return. We reserve the right to apply a 15% restocking charge.

Service / Repairs

We have a nationwide team of Service Technicians who can carry out all service or repair work to your product within the guarantee period and beyond. You have the assurance of a fully trained Mira Technician, genuine Mira spare parts and a 12 month guarantee on any chargeable work done.

Payment should be made directly to the Service Technician who will accept most major Credit or Debit cards.

To Contact Us

UK

Telephone: 0844 571 5000

Mon to Fri 8:00 am - 5:30 pm, Sat 8:30 am - 3:30 pm

E-mail: technical@mirashowers.com

Fax: 01242 282595

By Post: Mira Customer Services Dept, Cromwell Road, Cheltenham, Gloucestershire, GL52 5EP

Eire

Telephone: 01 459 1344

Mon to Thurs 8:45 am - 5:00 pm, Fri 8:45 am - 4:00 pm

E-mail: sales@modernplant.ie

Fax: Dublin 01 459 2329

By Post: Modern Plant Ltd (Dublin),

Otter House, Naas Road, Clondalkin, Dublin 22

Mira is a registered trade mark of
Kohler Mira Limited.

The company reserves the right to alter
product specifications without notice.



mira
SHOWERS