

Mira Element Exposed

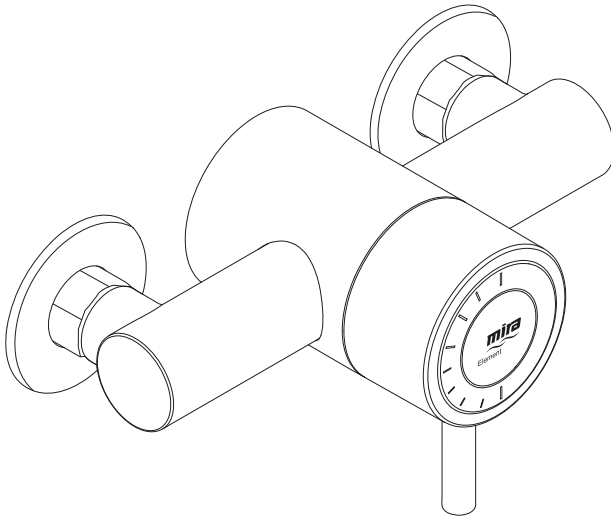

These instructions must be left with the user

Installation & User Guide

Showering perfection

mira
SHOWERS

Introduction

Thank you for choosing a Mira shower. To enjoy the full potential of your new shower, please take time to read this guide thoroughly, and keep it handy for future reference. Products manufactured by Kohler Mira Ltd are designed to be safe, provided that they are installed, used and maintained in good working order, in accordance with our instructions and recommendations.

Follow all warnings, cautions and instructions contained in this guide, and on, or inside the shower. This guide is also available in digital format from our website or by contacting our customer services department.

This product should not be disposed of with your general household waste. When this product has reached the end of its serviceable life please take it to a recognised facility such as your local civic amenity site for recycling.

Your local authority or retailer will be able to advise you of your nearest recycling facility.

Type 2 Valves

This product has been certified as a Type 2 valve. It also complies with the Water Supply (water fittings) regulations 1999. For further information on Type 2 Valves, refer to the ***TMV2 Requirements Manual***. The approved designation for this product is listed in the table below.

Mira Mixer Showers covered by this guide:

Product	Model Number	Colour	Type 2 Designation
Mira Element EV	B98A	Chrome	HP-S, HP-SE, LP-S
Mira Element Exposed (shower unit only)	B98Ab		

Guarantee

This product has been designed for **domestic use only**, Mira Showers guarantee this product against any defect in materials or workmanship for a period of **five** years from the date of purchase (shower fittings for **one** year).

Failure to follow the instructions provided with the shower will invalidate the guarantee.

For terms and conditions, refer to the rear cover of this guide.

Recommended Usage

Recommended Usage	
Domestic	✓
Light Commercial	✓
Heavy Commercial	✗
Healthcare	✗

Pack Contents

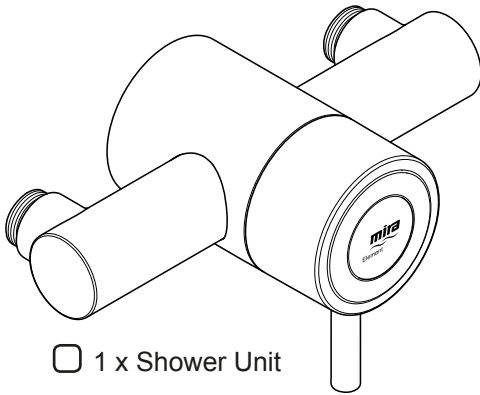

1 x Shower Unit

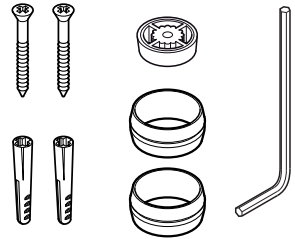

1 x Component Pack

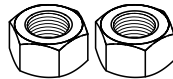

2 x Compression Nuts

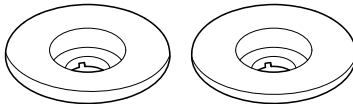

2 x Concealing Plates

Documentation

- 1 x Installation and User Guide
- 1 x TMV2 Requirements Manual
- 1 x Installation Template
- 1 x Guarantee Card

Important Safety Information

WARNING! This shower can deliver scalding temperatures. For continued safe operation, follow all instructions, warnings and cautions contained in this guide and on or inside the shower. Periodic maintenance may be required to keep the product in good working order.

The function of a thermostatic mixing valve is to deliver water consistently at a safe temperature. In keeping with every other mechanism, it cannot be considered as functionally infallible and as such, cannot totally replace a supervisor's vigilance where that is necessary. Provided it is installed, commissioned, operated and maintained within manufacturers recommendations, the risk of failure, if not eliminated, is reduced to the minimum achievable.

PLEASE OBSERVE THE FOLLOWING TO REDUCE THE RISK OF INJURY:

INSTALLING THE SHOWER

1. Installation of the shower must be carried out in accordance with these instructions by qualified, competent personnel. Read all instructions before installing the shower.
2. **DO NOT** install the shower where it may be exposed to freezing conditions. Ensure that any pipework that could become frozen is properly insulated.
3. **DO NOT** perform any unspecified modifications, drill or cut holes in the shower or fittings other than instructed by this guide. When servicing only use genuine Kohler Mira replacement parts.
4. If the shower is dismantled during installation or servicing then, upon completion, an inspection must be made to ensure all connections are tight and that there are no leaks.

USING THE SHOWER

5. The shower must be operated and maintained in accordance with the requirements of this guide. Make sure you fully understand how to operate the shower before use, read all instructions and retain this guide for future reference.

6. **DO NOT** switch the shower on if there is a possibility that the water in the shower unit or fittings is frozen.
7. The shower can be used by children aged from 8 years and above and persons with reduced physical, sensory or mental capabilities or lack of experience and knowledge if they have been given supervision or instruction concerning use of the appliance in a safe way and understand the hazards involved. Children must not be allowed to play with the shower.
8. Anyone who may have difficulty understanding or operating the controls of any shower should be attended whilst showering. Particular consideration should be given to the young, the elderly, the infirm or anyone inexperienced in the correct operation of the controls.
9. **DO NOT** allow children to clean or perform any user maintenance to the shower unit without supervision.
10. Always check the water temperature is safe before entering the shower.
11. **DO NOT** adjust the temperature control rapidly while using the shower.
12. Use caution when altering the water temperature while in use, always check the temperature before continuing to shower.
13. **DO NOT** switch the shower off and back on while standing in the water flow.
14. **DO NOT** connect the outlet of the shower to any tap, control valve, trigger handset or showerhead other than those specified for use with this shower. Only Kohler Mira recommended accessories must be used.
15. The showerhead must be descaled regularly. Any blockage of the showerhead or hose may affect showering performance.

Specifications

Plumbing	
Maximum Static Pressure	1000 kPa (10 bar)
Maximum Maintained Pressure	500 kPa (5 bar)
Minimum Maintained Pressure	10 kPa (0.1 bar = 1 metre head from base of cold tank to showerhead)
For optimum performance hot and cold water supplies should be nominally equal.	
Temperature Range - HOT	60°C - 65°C
Temperature Range - COLD	2°C - 25°C
Minimum Temperature Difference between HOT supply and OUTLET temperature	12°C (required to ensure safe shut down within 2 seconds if either HOT or COLD supplies fail)
Inlet	15 mm Male Compression
Outlet	1/2" BSP Male Flat Face

For Type 2 Valves, the supply conditions specified in the **TMV2 Requirements Manual** take precedence over the values above.

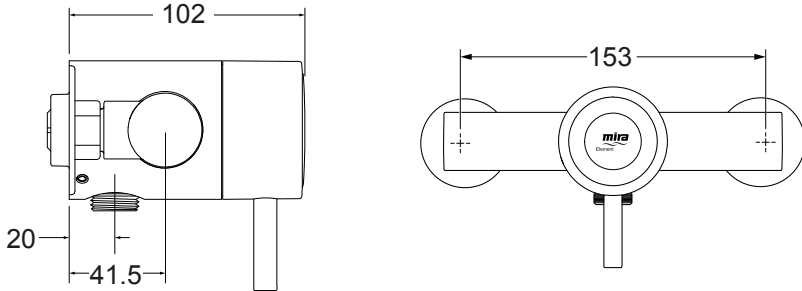

All dimensions in millimetres

Installation

Suitable Plumbing Systems

Gravity Fed:

The shower must be fed from a cold water cistern (usually located in the loft space) and a hot water cylinder (usually located in the airing cupboard) providing nominally equal pressures.

Gas Heated System:

The shower can be installed with a combination boiler provided the hot and cold water supply pressures are balanced when entering the shower.

Unvented Mains Pressure System:

The shower can be installed with an unvented, stored hot water system.

Mains Pressurised Instantaneous Hot Water System:

The shower can be installed with systems of this type with balanced pressures.

Pumped Systems:

The shower can be installed with an inlet pump (twin impeller). The pump must be installed on the floor next to the hot water cylinder.

General

1. Installation of the shower must be carried out in accordance with these instructions by qualified, competent personnel.
2. The plumbing installation must comply with all national or local water regulations and all relevant building regulations, or any particular regulation or practice specified by the local water supply company.
3. Make sure all pressures and temperatures comply with the requirements of the shower. See '**Specifications**'. For Type 2 Valves, refer to supply conditions given in the **TMV2 Requirements Manual**.
4. Full bore/non restrictive servicing valves must be fitted in a readily accessible position adjacent to the shower to facilitate maintenance of the shower. **DO NOT** use a valve with a loose washer plate (jumper) as this can lead to a build up of static pressure.
5. **DO NOT** apply excessive force to plumbing connections; always provide mechanical support when making plumbing connections. Any soldered joints should be made before connecting the shower.
6. Pipework dead-legs should be kept to a minimum.

7. **DO NOT** install the shower unit in a position where access for maintenance is restricted.
8. The shower must be fitted to a waterproof, flat and even wall surface. The 2 screws (No. 8 x 1¼") and wall plugs supplied are suitable for most solid wall installations. Alternative fixing screws for panel structures are not supplied. Use both fixing points to secure the shower, be sure to use fixings appropriate for the chosen wall structure.

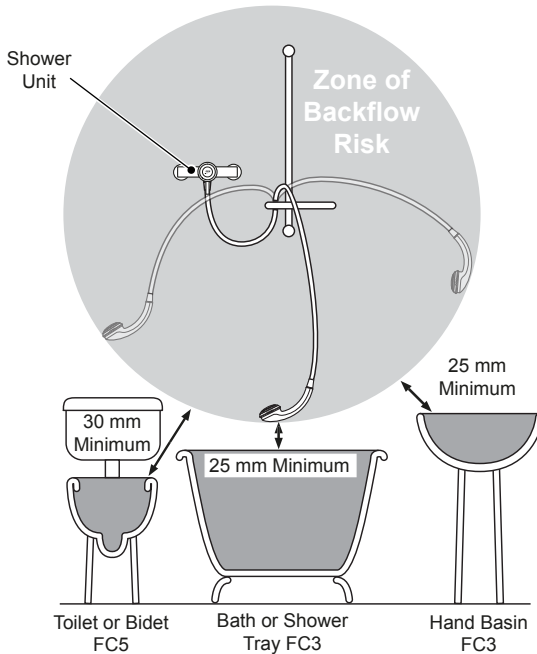

Note! There will be occasions when the hose retaining ring will not provide a suitable solution for Fluid Category 3 installations. In these instances an outlet double checkvalve must be fitted, this will increase the required supply pressure typically by 10kPa (0.1 bar). Double checkvalves fitted in the inlet supply to the appliance cause a pressure build up, which affects the maximum static inlet pressure for the appliance and must not be fitted. For Fluid Category 5, double checkvalves are not suitable.

9. The position of the shower and shower fittings must provide a minimum air gap of 25mm between the showerhead and the spill over level of any bath, shower tray or basin. There must be a minimum distance of 30mm between the showerhead and the spill over lever of any toilet, bidet or other appliance with a Fluid Category 5 backflow risk.
10. Position the shower unit where the controls are at a convenient height for the user. Position the showerhead so that the water sprays in line with the bath or across the opening of a shower cubicle. The installation must not cause the shower hose to be kinked during normal use.
11. The water supplies to this product should be isolated if the product is not to be used for a long period of time. If the product or pipework is at risk of freezing during this period they should also be drained of water.

Installation of the Shower Unit

Warning, isolate the water supplies before installing the shower!

1

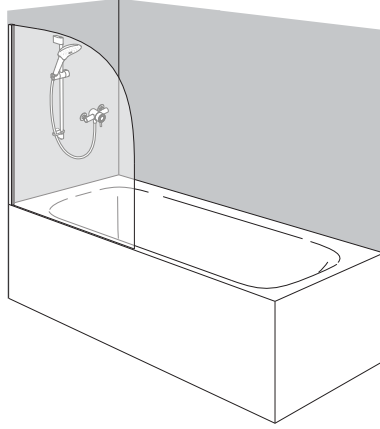
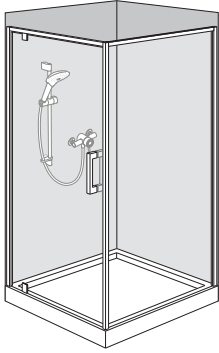

Decide on a suitable position for the shower unit and fittings.
See '**Installation - General**' for further details.

2

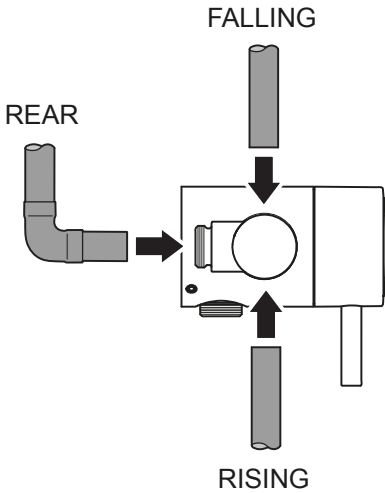

3

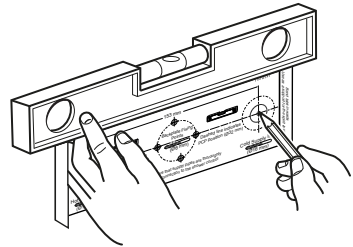
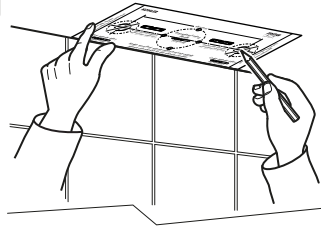

Determine the route for the supply pipes. For rear inlet, use an elbow fitting. We recommend a falling supply to prevent air locks.

Use the template provided to mark the positions of the pipes and fixing holes (choose either the vertical pair or the horizontal pair).

4

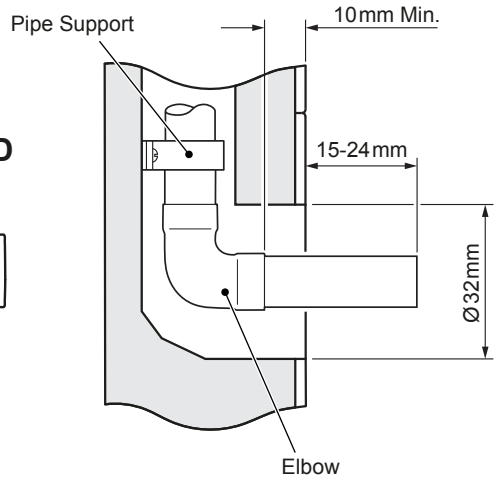
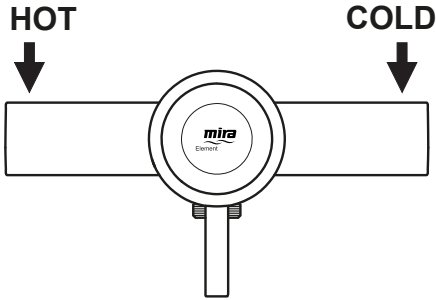

Fit the supply pipework, **HOT** and **COLD** supplies can be reversed. Any recessed inlet pipes must extend 15-24mm from the finished wall surface, and be square to the wall.

5

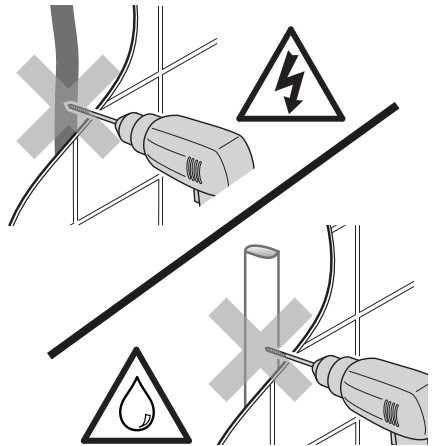
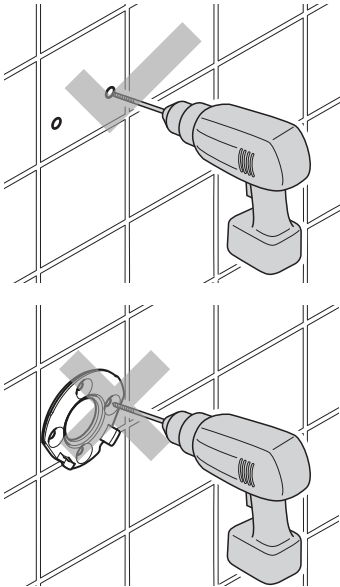

Ø6mm drill required for wall plugs supplied

Drill the fixing holes for the backplate.

DO NOT drill through the backplate into the wall.

DO NOT drill into buried cables or pipes.

Note! Backplate has four fixing holes. Only two holes are required for fixing.

6

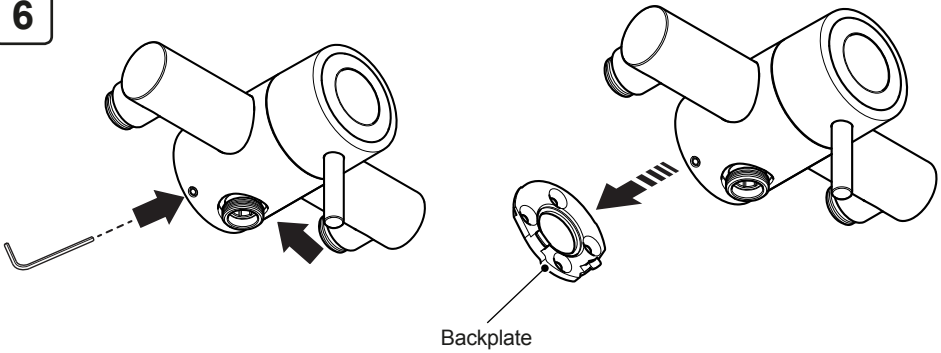

Loosen the two hexagonal screws and remove the backplate from the shower unit.

7

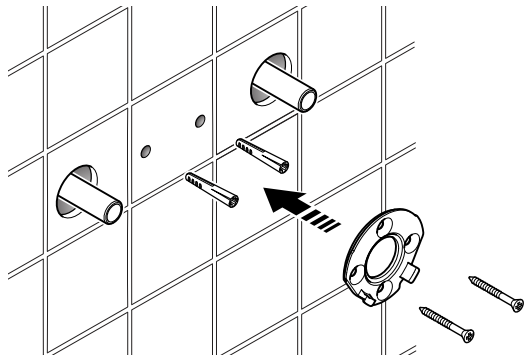

Fix the backplate to the wall using, 2 x No. 8 x 1¼" screws and wall plugs (supplied).

8

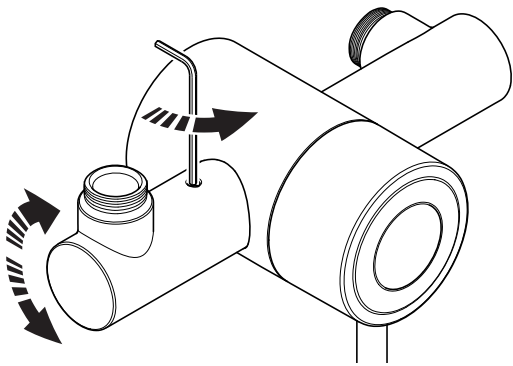

To adjust the shower unit for falling/rising water supplies, loosen the hexagonal screws and rotate the elbows. Re-tighten the screws to secure the elbows, ensuring the elbows are pushed firmly back against the body.

9

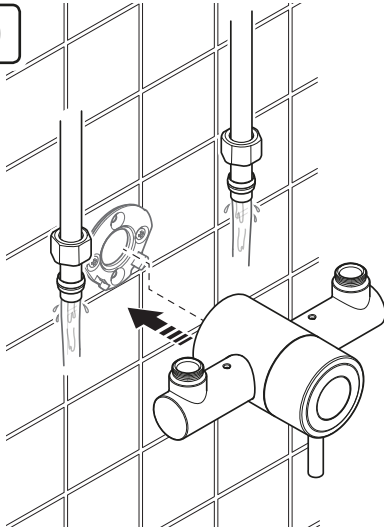

FALLING SUPPLIES

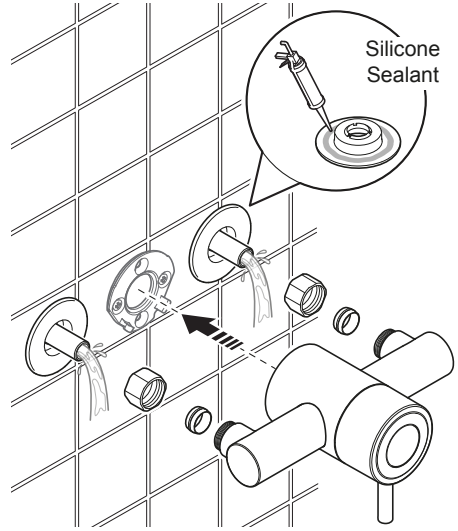

REAR SUPPLIES

Flush the water supplies thoroughly before connecting the shower unit.

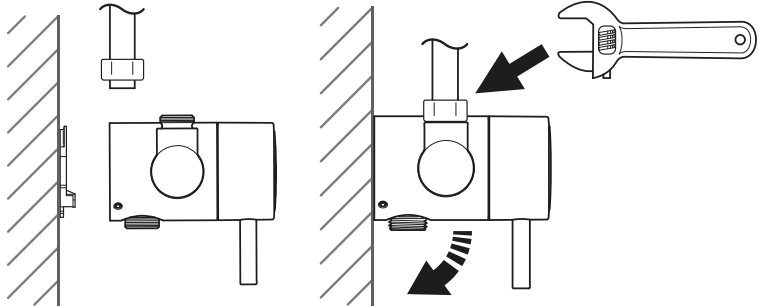

Fit the shower unit over the backplate and secure to the pipework. Avoid damage to the chrome finish when tightening the compression nuts.

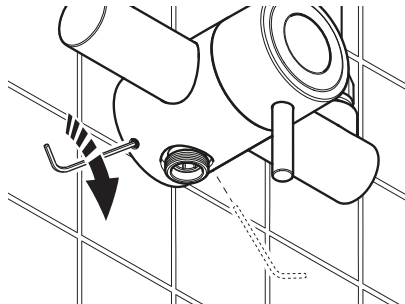

Secure the shower unit to the backplate. **DO NOT** overtighten the screws.

10

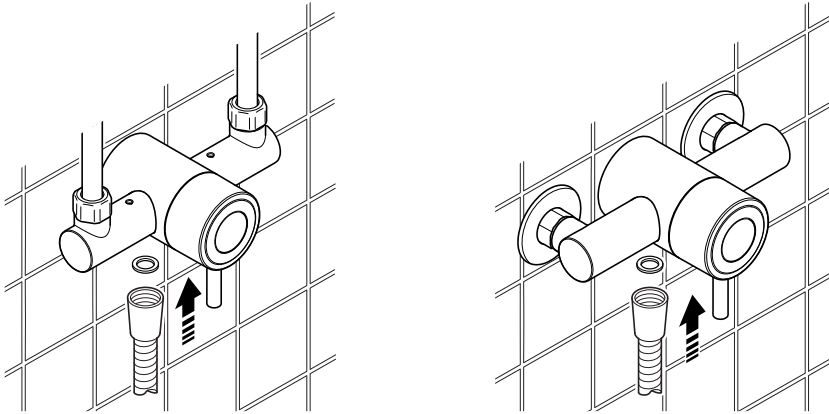

Install the shower's outlet fittings, see '*Shower Fittings Installation & User Guide*' for instructions. Fit the shower hose with a 15mm rubber washer. Turn on the water supply and test the shower.

Reversed Inlet Supplies

If the **HOT** water supply is on the **RIGHT HAND** side, the shower's control cartridge must be reversed. The following steps show how to swap the hot and cold water inlet positions of the cartridge.

Isolate the water supplies and turn the shower on/off to relieve the water pressure.

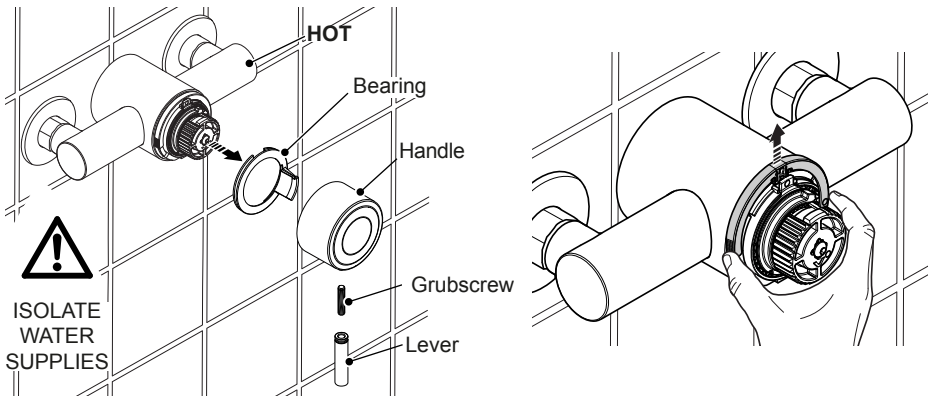

Carefully unscrew the lever and the grubscrew and remove the handle along with the bearing. Unclip the snap ring as shown.

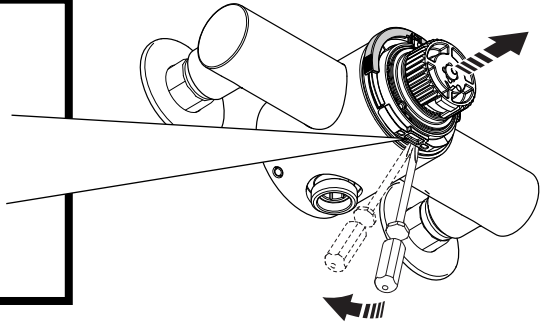
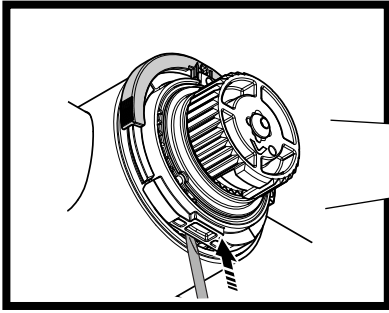

Lever the cartridge out using a suitable flat blade screwdriver. Continue to lever the cartridge until it can be removed easily by hand.

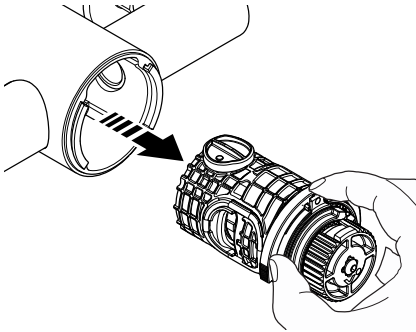

Remove the cartridge.

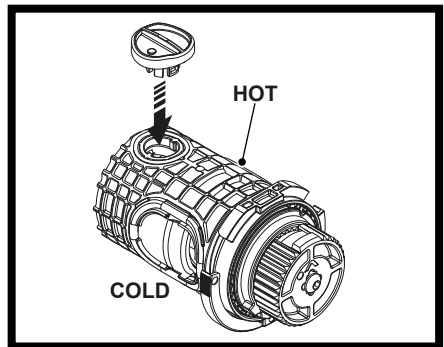
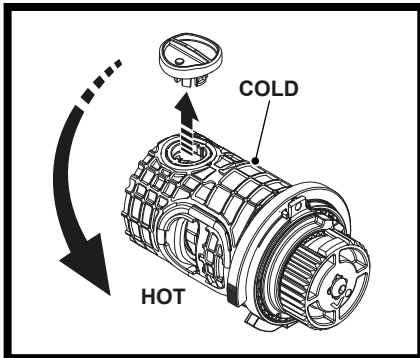

Remove the bung from the top of the cartridge. Place the bung in the opposite side.

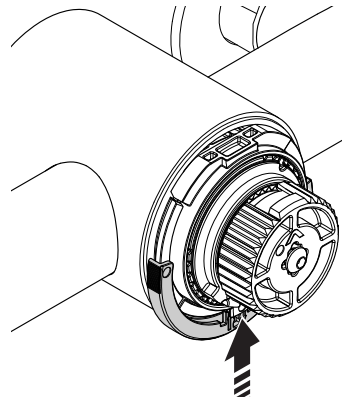
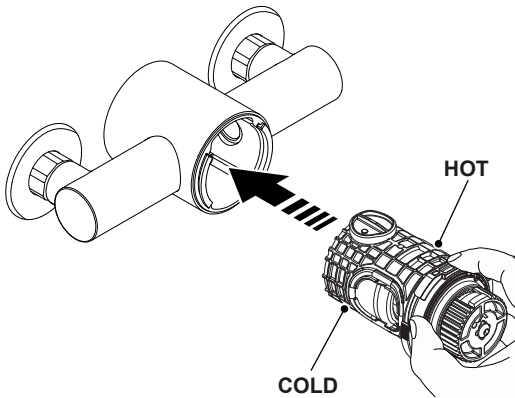

Insert the cartridge and slide the snap ring into place.

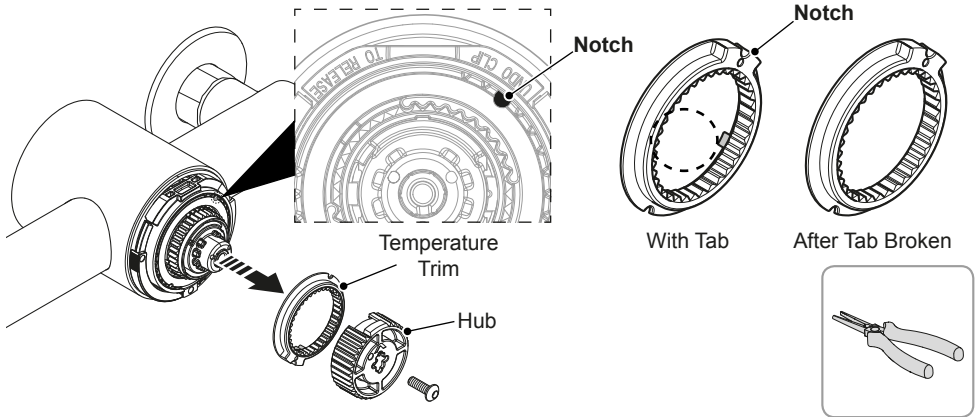

Remove the hexagonal screw and remove the hub and the temperature trim.

Break off the tab on the temperature trim using pliers.

Rotate the temperature trim by 180 degrees and replace, ensuring the notch on the temperature trim lines up with the notch on the cartridge.

Refit the previously removed hub, ensuring the location lugs on the hub match up with those on the cartridge.

Use the hexagonal screw to secure.

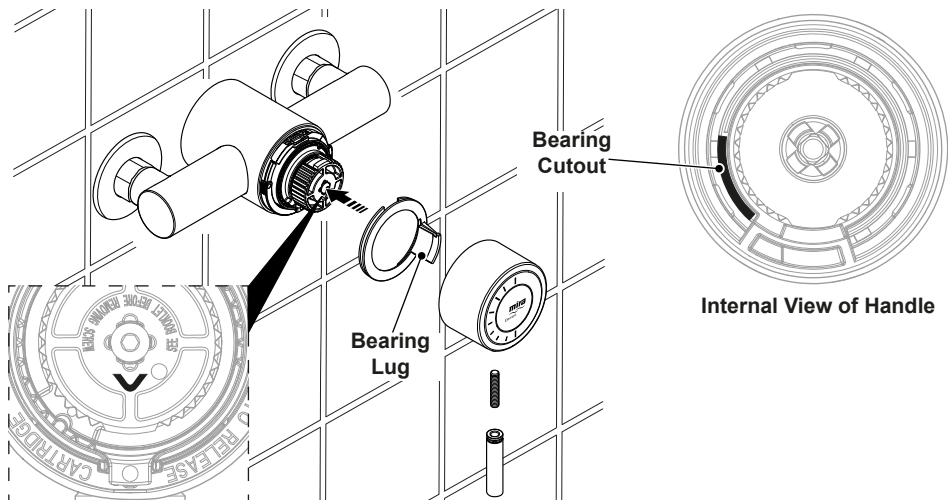

Refit the bearing ensuring the lug is in the bottom right hand corner. Replace the handle ensuring that the arrow on the yellow hub is pointing downwards, and ensuring the cutout on the inside of the handle matches up with the lug on the bearing. Refit the grub screw and the control lever.

Flow Regulators

The shower unit is fitted with a 12 L/min (red) flow regulator. This may be changed to the 6 L/min (black) supplied.

We recommend the following as a general guideline for water pressures:

12 L/min (red) for maintained (running) water pressure greater than 0.5 bar. To help resolve issues such as:

1. Excessive shower force.
2. Noise due to high or unequal water pressure.
3. Unstable supply temperatures.

6 L/min (black) for maintained (running) water pressure greater than 0.5 bar to conserve the most water while showering.

Note! The 6 L/min flow regulator may affect the performance of some combination boilers while the shower is running. Check with the boiler's manufacturer before fitting the flow regulator.

Remove the flow regulator if the shower force is too low.

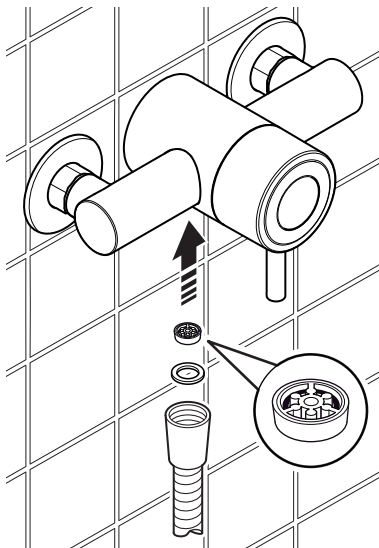

Commissioning

Follow this procedure to check and adjust the temperature before using the shower for the first time. **Make sure that all users are familiar with the operation of the shower. This guide is the property of the homeowner.**

The shower's safe hot temperature has been preset to 41°C under ideal conditions at the factory (Hot inlet = 60 - 65°C, Cold inlet = 15 - 20°C, Pressure = 2 bar equal), but may require adjustment for the following reasons:

- To reset to 41°C (may be required to suit your home's plumbing system)
- To suit your showering preference.

Note! For Type 2 installations the maximum temperature is determined by application, refer to the **TMV2 Requirements Manual**.

The following procedure requires a constant supply of hot water at a minimum temperature of 55°C.

1

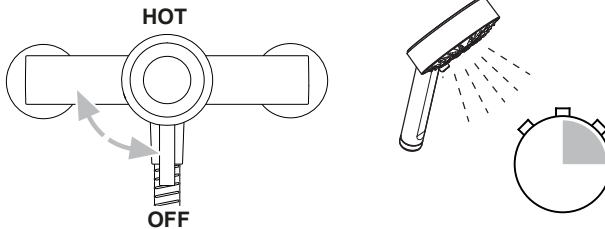

Turn the handle until water starts to flow, allow a few seconds for the temperature adjustment to take full effect, check that the product is flowing cold water.

Turn the handle to full hot, allow a few seconds for the temperature and flow to stabilise, check that the product is flowing hot water. This represents a safe hot temperature to shower with.

Stop the shower by turning the handle back to it's original position.

2

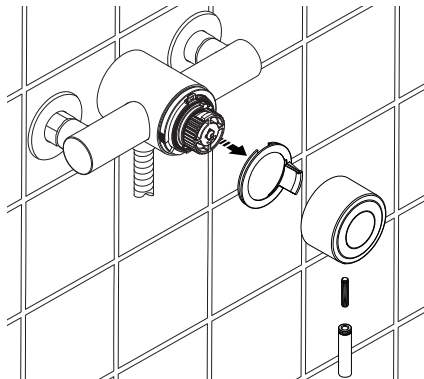

If this temperature needs to be either warmer or cooler, carefully remove the lever, the grub screw, the handle and the bearing.

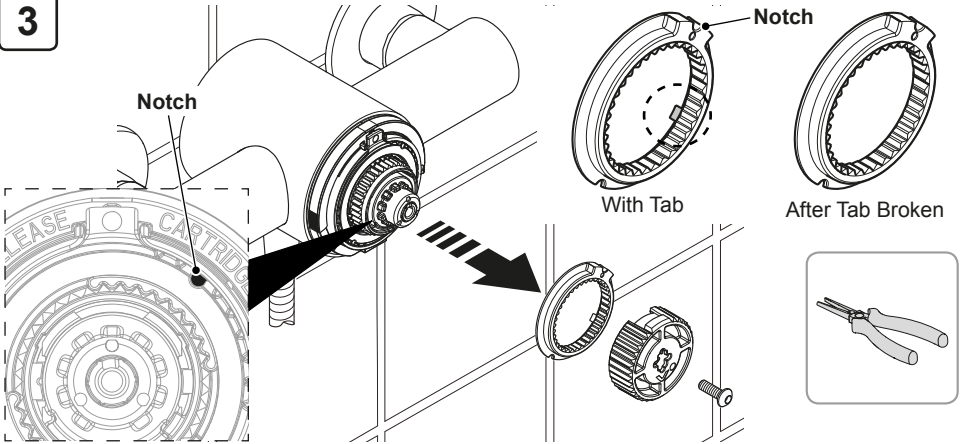
3

Remove the hexagonal screw and remove the hub and the temperature trim. Break off the tab on the temperature trim to adjust the temperature.

clockwise = warmer

anticlockwise = cooler

1 Notch = approx. 1°C

Refit the temperature trim and the hub, ensuring the location lugs on the hub match up with those on the cartridge. Replace the hexagonal screw without overtightening.

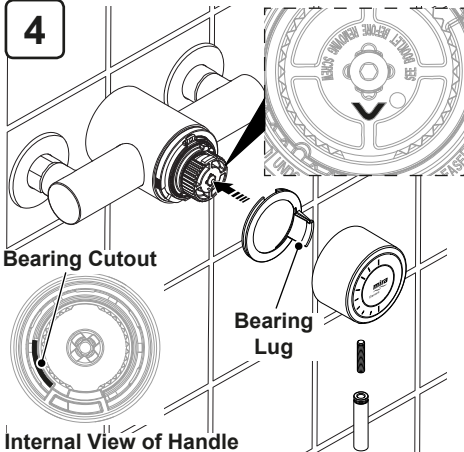
4

Internal View of Handle

Refit the bearing, ensuring the lug is in the bottom right hand corner. Replace the handle, ensuring that the arrow on the yellow hub is pointing downwards. Ensure that the cutout on the inside of the handle matches up with the lug on the bearing. Refit the grubscrew and the control lever.

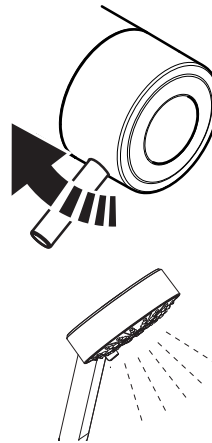
5

Check the maximum showering temperature by turning the handle fully clockwise.

Operation

Please read '**Important Safety Information**' before using the shower for the first time.

Note! This valve has no flow control.

1

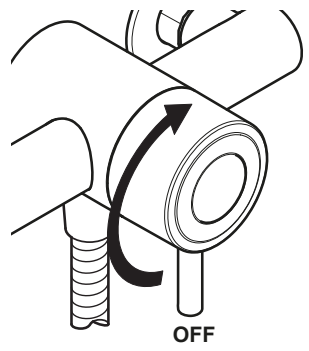

Turn the handle to adjust the temperature.

Max Set Temp

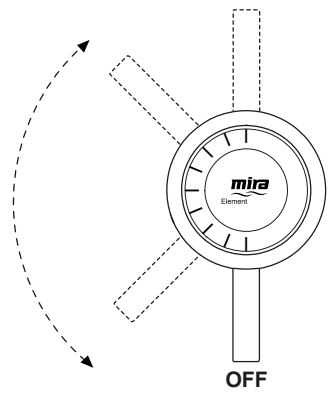

2



Check the water temperature before entering the shower. The hot temperature setting can be altered, see '**Commissioning**'.

3

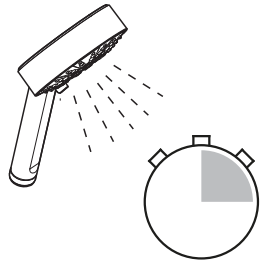

Allow a few seconds for any temperature adjustment to take effect. Allow the temperature to stabilise before making a new adjustment.

4

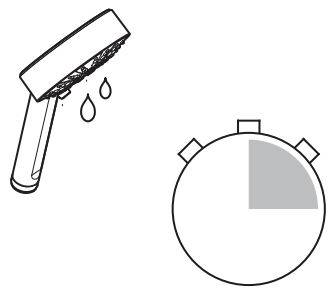

Once turned off, residual water may drain for a few minutes.

User Maintenance

WARNING! PLEASE OBSERVE THE FOLLOWING TO REDUCE THE RISK OF INJURY OR PRODUCT DAMAGE:

- **DO NOT** allow children to clean or perform any user maintenance to the shower unit without supervision.
- If the shower is not to be used for a long period, the water supply to the shower unit should be isolated. If the shower unit or pipework is at risk of freezing during this period, a qualified, competent person should drain them of water.

Cleaning/Replacing Filter

1

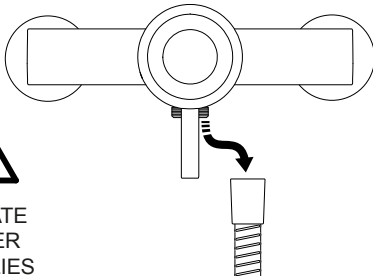

ISOLATE
WATER
SUPPLIES

Isolate the water supplies. Turn the shower on and off to relieve pressure. Disconnect the hose from the shower unit.

2

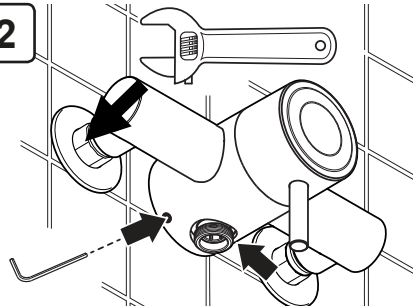

Loosen the hexagonal screws as shown and both of the compression nuts. Avoid damage to the chrome finish when loosening the compression nuts.

3

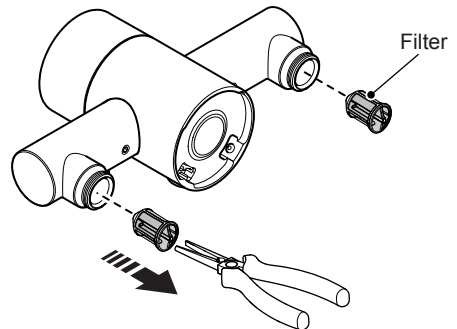
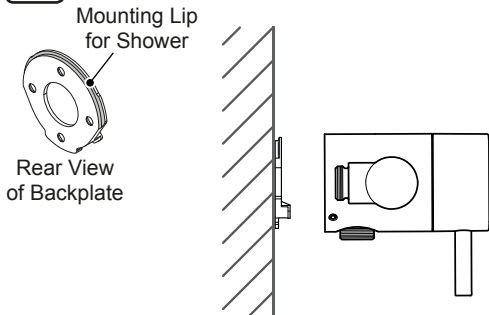

Remove the shower unit from the wall. The filters are retained in the elbows, remove them using a suitable tool and inspect for damage or debris blockage.

4

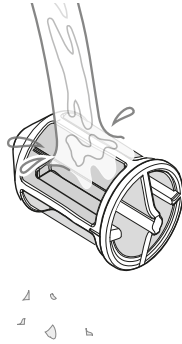

Rinse each filter in clean warm water, removing any dirt or debris. Replace if the filter mesh is damaged. Make sure both filters are refitted correctly into the elbows.

5

Mounting Lip
for Shower



Rear View
of Backplate

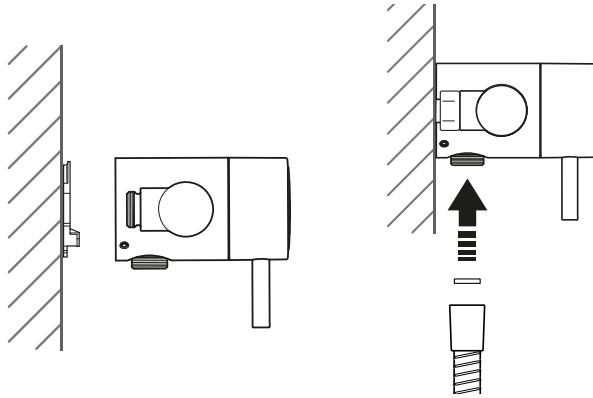

Refit the shower unit to the wall and the pipes. Reconnect the shower hose, then restore the water supplies and check for leaks.

Cleaning

Many household and commercial cleaners, including hand and surface cleaning wipes contain abrasives and chemical substances that can damage plastics, plating and printing and should not be used.

Important! The showerhead must be descaled regularly. Keeping the shower spray clean and free from limescale will ensure that your shower continues to give the best performance.

In-service Tests

The principal means for determining the continuing satisfactory performance of the shower unit is the in-service test, refer to the **TMV2 Requirements Manual**.

Frequency of In-service Tests - Commercial (non-domestic installations)

Check for correct blend setting every 6 months.

Fault Diagnosis

Only use genuine Kohler Mira replacement parts.

If you require a Mira trained service engineer or agent, please see '**Customer Service**' on the back cover of this guide.

Symptom	Cause	Recommended Action
Only hot or cold water from the shower.	No hot or cold water reaching the shower unit.	Check the filters for any blockage. See ' User Maintenance '.
	Water inlets are reversed (hot supply feeding the cold inlet of the shower unit), but the shower unit cartridge has not been adjusted.	Adjust the shower unit cartridge. See ' Reversed Inlet Supplies '.
The shower temperature is either too hot or too cold.	No hot or cold water reaching the shower unit.	Check there is an adequate supply of hot water. See ' Specifications '. Some combination type boilers may not produce sufficient hot water for the desired flow rate, see ' Specifications '. Fit the flow regulator supplied to the outlet of the shower unit. For more information, contact Mira Showers or visit www.mirashowers.co/uk
		Check the filters for any blockage. See ' User Maintenance '.
	The temperature indicated is too hot or too cold	Adjust the temperature as required, see " Commissioning ".
No water flow or fluctuating/reduced water flow.	Hose, shower head or filters blocked.	Remove and clean. Check hose and replace if necessary. Check the filters for any blockage. See ' User Maintenance '.
	Flow regulator fitted incorrectly.	Check flow regulator.
	The inlet pressures are insufficient or unbalanced.	See ' Specifications '.
	The inlet temperature differentials are insufficient.	See ' Specifications '.

Symptom	Cause	Recommended Action
	Air lock or partial blockage in the pipework.	Flush inlet pipes.
Fluctuating temperature.	Flow too low for combination boiler - boiler cycling.	Remove flow regulator, check the shower head and hose for blockages.
Water leaking from the shower head.	Water may drain from the showerhead for a short period after use.	No action required.
	The inlet pressures exceed the requirements for the shower unit.	See ' <i>Specifications</i> '.
	Damage to the shower unit cartridge.	Replace.

Spare Parts

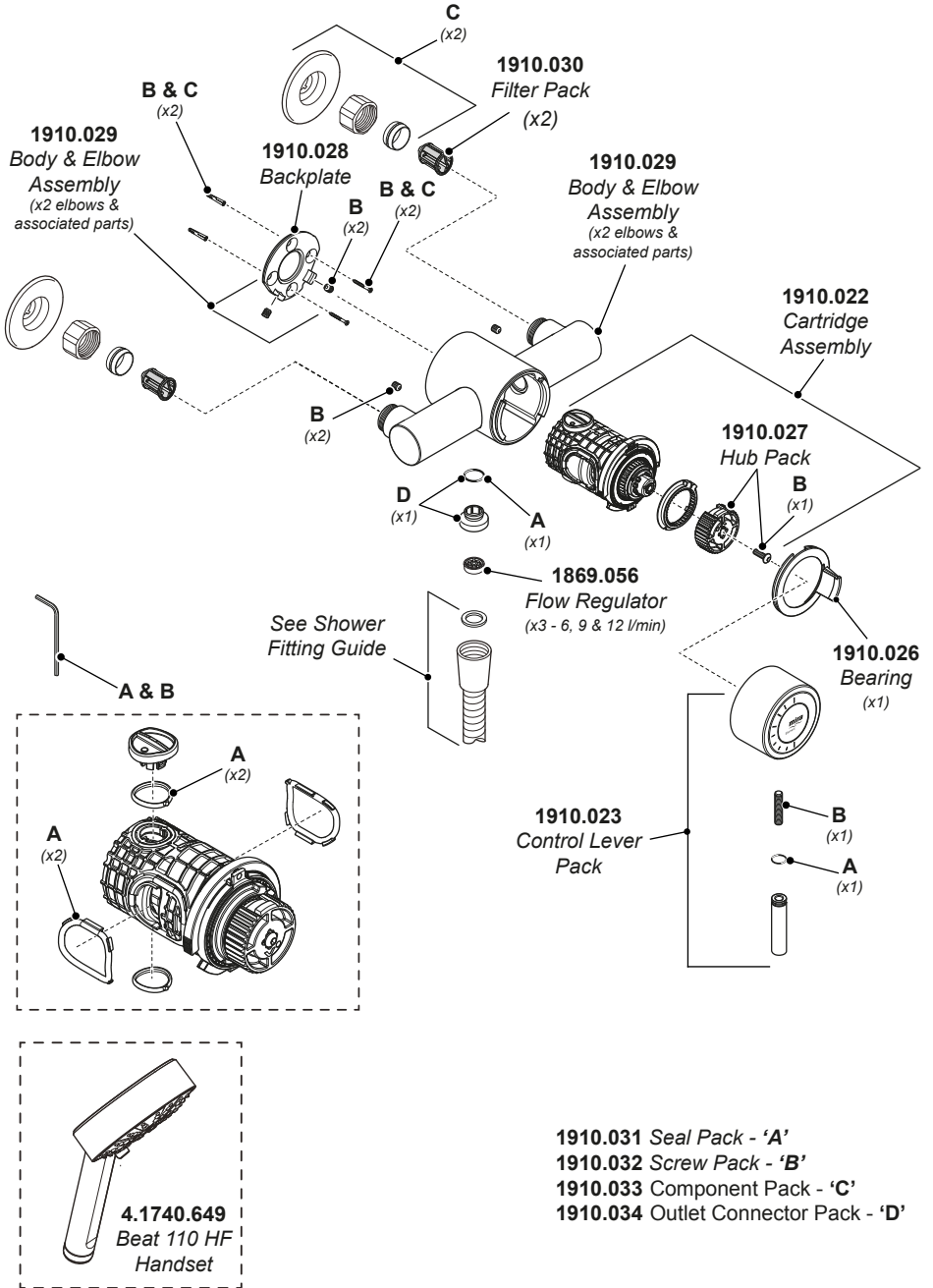

Notes

Notes

Customer Service

Guarantee

Your product has the benefit of our manufacture's guarantee which starts from date of purchase. This guarantee only applies in the United Kingdom and Republic of Ireland. To activate this guarantee, please return your completed registration card, visit our website or free phone 0800 5978551 within 30 days of purchase (UK only).

Within the guarantee period we will resolve defects in materials or workmanship, free of charge, by repairing or replacing parts or product as we may choose.

This guarantee is in addition to your statutory rights and is subject to the following conditions :

- The guarantee applies solely to the original installation under normal use and to the original purchaser only. The product must be installed and maintained in accordance with the instructions given in this guide.
- Servicing must only be undertaken by us or our appointed representative.
Note! If a service visit is required the product must be fully installed and connected to services.
- Repair under this guarantee does not extend the original expiry date. The guarantee on any replacement parts or product ends at the original expiry date.
- For shower fittings or consumable items we reserve the right to supply replacement parts only.

The guarantee does not cover:

- Call out charges for non product faults (such as damage or performance issues arising from incorrect installation, improper use, inappropriate cleaning, lack of maintenance, build up of limescale, frost damage, chemical attack, corrosion, system debris or blocked filters) or where no fault has been found with the product.
- Water or electrical supply, waste and isolation issues.
- Compensation for loss of use of the product or consequential or indirect loss of any kind.
- Damage or defects caused if the product is repaired or modified by persons not authorised by us or our appointed representative.
- Routine maintenance or replacement parts to repaired or modified by persons not authorised by comply with the requirements of the TMV2 or repaired or modified by persons not authorised by TMV3 healthcare schemes
- Accidental or wilful damage.
- Products purchased ex-showroom display.

What to do if something goes wrong

If your product does not work correctly refer to this manual for fault diagnosis and check that it is installed and commissioned in accordance with our instructions. If this does not resolve the issue, contact us for help and advice.



Helpdesk Service

Contact our Customer Services Team for product advice, to purchase spare parts or accessories or to set up service visit. You can contact us via phone or e-mail - contact details below.

Please provide your model name, power rating (if applicable) and date of purchase.



Mira Showers Website

(www.mirashowers.co.uk)

Visit our website to register your guarantee, download user guides, diagnose faults, purchase our full range of accessories and popular spares, or request a service visit.



Spares and Accessories

We hold the largest stocks of genuine Mira spares and accessories. Contact us for a price or visit our website to purchase items from our accessory range and popular spares. (Only available in the United Kingdom)



Service/Repairs

No one knows our products better than our nationwide team of Service Technicians. We can carry out service or repair work to your product both during and after the guarantee period. (Only available in the United Kingdom and Republic of Ireland) Ask about our fixed price service repairs.

To Contact Us: UK



0844 571 5000

Calls cost 7p per minute plus your phone company's access charge



Fax: 01242 282595



Email – Visit

www.mirashowers.co.uk/contactus



By Post: **Mira Customer Services Dept, Cromwell Road, Cheltenham, Gloucestershire GL52 5EP**

To Contact Us: Eire Only



01 531 9337



E-mail:

CustomerServiceEire@mirashowers.com

Mira is a registered trade mark of Kohler Mira Limited.

The company reserves the right to alter product specifications without notice.



mira
SHOWERS