

Mira Virtue Thermostatic Mixer

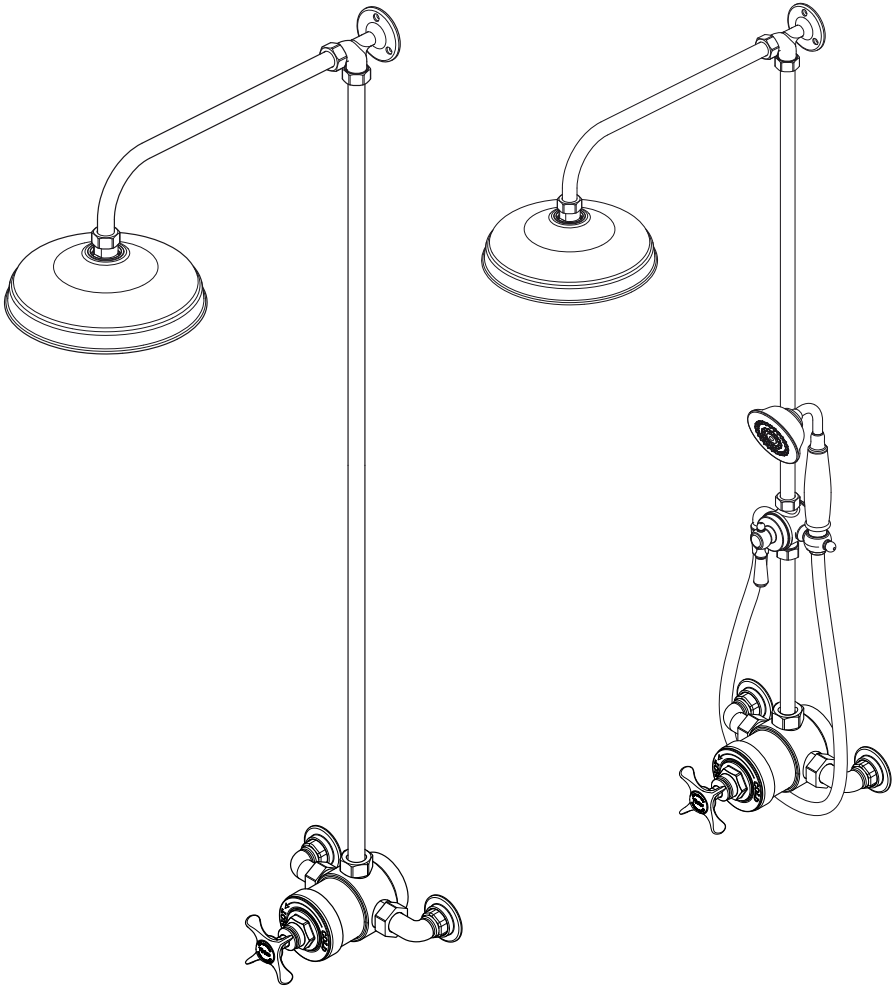

These instructions must be left with the user

Installation & User Guide

Showering perfection

mira
SHOWERS

Important Safety Information

Mira thermostatic mixers are precision engineered and should give continued safe and controlled performance, provided:

1. They are installed, commissioned, operated and maintained in accordance with manufacturer's recommendations.
2. Periodic attention is given, when necessary, to maintain the product in good functional order.

Caution!

1. Read all of these instructions.
2. Retain this guide for later use.
3. Pass on this guide in the event of change of ownership of the installation site.
4. Follow all warnings, cautions and instructions contained in this guide.
5. Anyone who may have difficulty understanding or operating the controls of any shower should be attended whilst showering. Particular consideration should be given to the young, the elderly, the infirm or anyone inexperienced in the correct operation of the controls.
6. Rapid/Excessive movement of the flow and/or temperature control levers may result in momentary unstable blend temperatures.
7. Care is required when adjusting flow or temperature, make sure that the temperature has stabilised.
8. When this product has reached the end of its serviceable life, it should be disposed of in a safe manner, in accordance with current local authority recycling, or waste disposal policy.
9. The function of a thermostatic mixing valve is to deliver water consistently at a safe temperature. In keeping with every other mechanism, it cannot be considered as functionally infallible and as such, cannot totally replace a supervisor's vigilance where that is necessary. Provided it is installed, commissioned, operated and maintained within manufacturers recommendations, the risk of failure, if not eliminated, is reduced to the minimum achievable.

Introduction

Thank you for purchasing a quality Mira product. To enjoy the full potential of your new product, please take time to read this guide thoroughly, having done so, keep it handy for future reference.

The Mira Virtue thermostatic mixer is a thermostatic shower control with a single control lever for on/off and temperature control. A 12 L/Min flow regulator is supplied for high pressure systems to reduce excessive shower force.

The thermostatic mixer incorporates a wax capsule temperature sensing unit, which provides an almost immediate response to changes in pressures or temperature of the incoming water supplies to maintain the selected temperature. An adjustable maximum temperature stop is provided which limits the temperature to a safe level. Inlet filters are fitted to protect the thermostatic cartridge.

Mira Virtue: Thermostatic Mixer for connection to rising, falling or rear entry pipework, supplied with a deluge head.

Mira Virtue with Diverter: Thermostatic Mixer for connection to rising or rear entry pipework, supplied with a diverter valve which gives the option of using the handset, deluge head or both.

Mira Mixer Showers covered by this guide:

Product	Model Number	Colour
Mira Virtue	1.1927.002	Chrome
Mira Virtue with Diverter	1.1927.001	

Guarantee

For **domestic installations**, Mira Showers guarantee the Mira Virtue against any defect in materials or workmanship for a period of five years from the date of purchase (shower fittings for one year).

For **non-domestic installations**, Mira Showers guarantee the Mira Virtue against any defect in materials or workmanship for a period of one year from the date of purchase.

For terms and conditions refer to the back cover of this guide.

Recommended Usage

Recommended Usage	
Domestic	✓
Light Commercial	✗
Heavy Commercial	✗
Healthcare	✗

Patents and Design Registration

GB: 2 291 693, 2 392 225, 2 422 886

Euro: 1 672 257 DE FR GB IT NL SE

USA: 7 240 850

Patent Applications:

Euro: 07015846.4

USA: 2006-0124758-A1, 2010-0219255-A1

Pack Contents

Tick the appropriate boxes to familiarise yourself with the part names and to confirm that all of the parts are included.

Mira Virtue



4 x Compression Nuts (18 mm)



4 x Olives (18 mm)

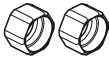

2 x Compression Nuts (15 mm)



2 x Olives (15 mm)



5 x Wall Plugs



3 x Fixing Screws (Chrome - Wall Bracket)



2 x Fixing Screws



2 x Concealing Plates



1 x Flow Regulator & Adapter



1 x 2.5 mm Hexagonal Key



1 x 'O' Key



1 x Wall Bracket

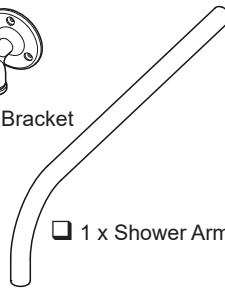

1 x Shower Arm

1 x Rigid Riser

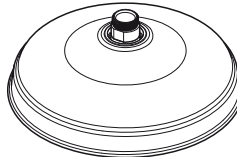

1 x Deluge Head

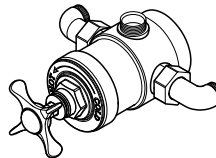

1 x Thermostatic Mixing Valve



1 x 3 mm Hexagonal Key

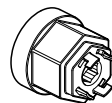

1 x Cartridge Removal Tool

1 x Installation & User Guide

1 x Guarantee Registration Document

1 x Installation Template

Mira Virtue with Diverter

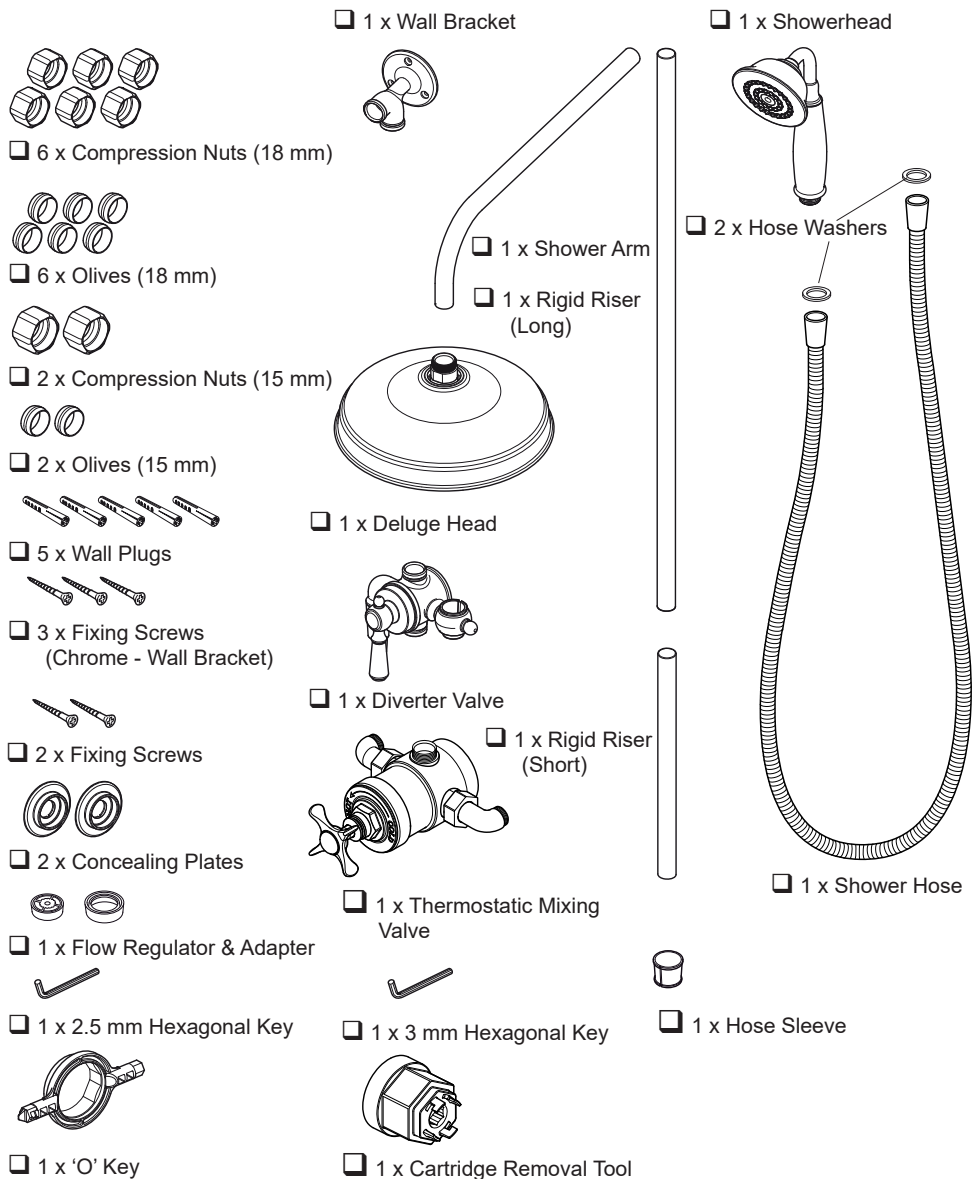

- 1 x Installation & User Guide
- 1 x Guarantee Registration Document
- 1 x Installation Template

Specifications

Pressures

- Max Static Pressure: **10 Bar**.
- Max Maintained Pressure: **5 Bar**.
- Min Maintained Pressure (Gravity System): **0.1 Bar** (0.1 bar = 1 Metre head from cold tank base to showerhead outlet).
Note! For gravity fed or other low pressure systems (0.5 bar or below) do not fit the outlet flow regulator.
- For optimum performance supplies should be nominally equal.

Temperatures

- Factory Pre-set at safe temperature under ideal inlet supply conditions. See '**Commissioning**'.
- Optimum Thermostatic Control Range: **35°C to 43°C** (achieved with supplies of 15°C cold, 65°C hot and nominally equal pressures).
- Recommended Hot Supply: **60°C to 65°C** **Note!** The mixing valve can operate at higher temperatures for short periods without damage, however this could detrimentally affect thermostatic performance. For safety and performance reasons it is recommended that the maximum hot water temperature is limited to **65°C**.
- Cold Water Range: up to **25°C**.
- Minimum Recommended Differential between Hot Supply and Outlet Temperature: **12°C**.

Thermostatic Shut-down

- For safety and comfort the thermostat will shut off the mixing valve **within 2 Seconds** if either supply fails (achieved only if the hot water supply temperature is 12°C above the set blend temperature).

Connections

- Inlets: 15 mm Compression.
- Outlet: ½" BSP Flat Face / 15 mm Compression
- Standard connections are: **hot - left, cold - right, outlet - top**.

Flow Rates

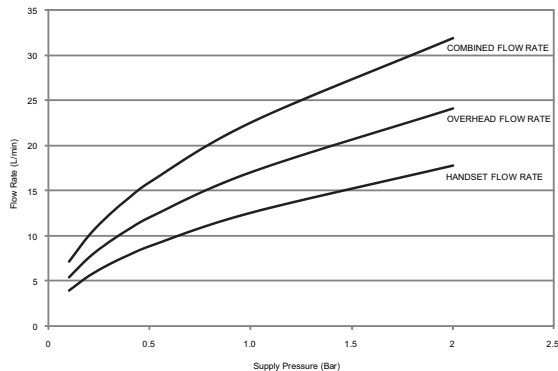

Dimensions

Mira Virtue

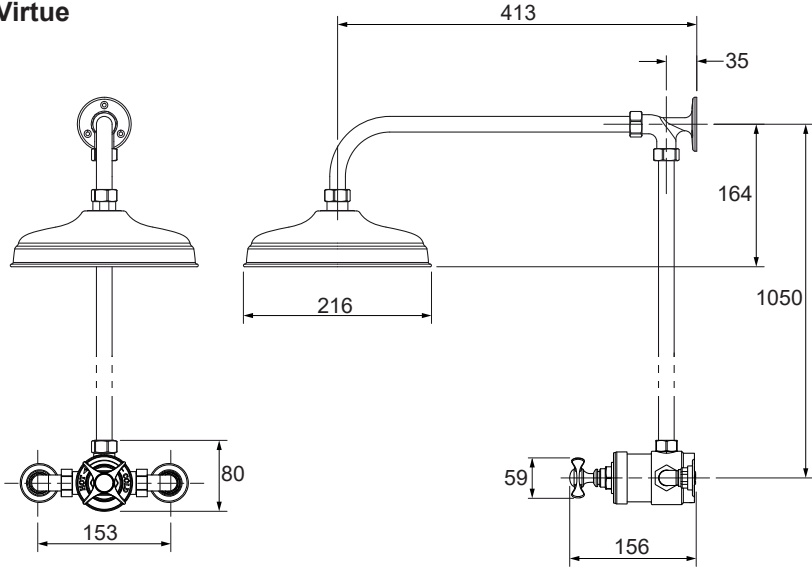

Mira Virtue with Diverter

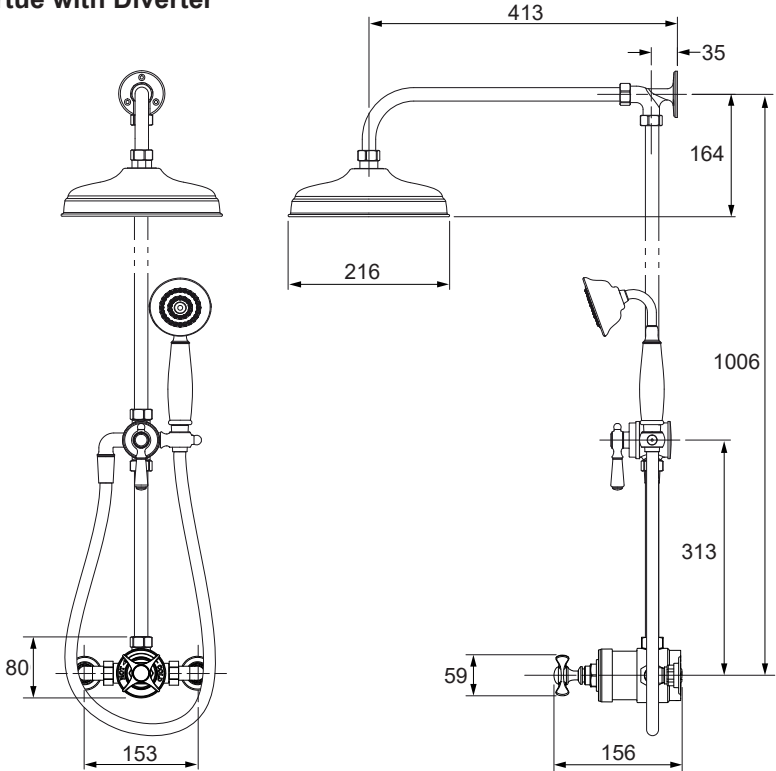

All dimensions in mm

Installation

Suitable Plumbing Systems

Gravity Fed:

The thermostatic mixer must be fed from a cold water cistern (usually fitted in the loft space) and a hot water cylinder (usually fitted in the airing cupboard) providing nominally equal pressures.

Mains Pressurised Instantaneous Hot Water System (Combination Boiler):

The thermostatic mixer can be installed with systems of this type with balanced pressures. (Recommended Minimum Maintained Pressure: **1.0 Bar**).

There is no flow adjustment with this product. A 12 l/min flow regulator is supplied and is recommended to be fitted in High Pressure systems(see Flow Regulator Installation)

Unvented Mains Pressure System:

The thermostatic mixer can be installed with an unvented, stored hot water system. There is no flow adjustment with this product. A 12 l/min flow regulator is supplied and is recommended to be fitted in High Pressure systems(see Flow Regulator Installation)

Pumped Systems:

The thermostatic mixer can be installed with an inlet pump (twin impeller). The pump must be installed in a suitable location and in accordance with its instructions.

General

Installation must be carried out in accordance with these instructions, and must be conducted by designated, qualified and competent personnel.

The installation must comply with the “Water Supply Regulations 1999 (Water Fittings)” or any particular regulations and practices, specified by the local water company or water undertakers.

Note! Make sure that all site requirements correspond to the information given in section: ‘**Specifications**’.

1. The Mixer must not be installed in an area where it may freeze.
2. For stud partitions alternative fixings may be required.
3. Isolating valves must be installed close to the Mixer for ease of maintenance.
4. Pipework must be rigidly supported and avoid any strain on the connections.
5. Pipework dead-legs should be kept to a minimum.

6. Decide on a suitable position for the Mixer. The position of the Mixer and the Shower Fittings must provide a minimum gap of 25 mm between the spill-over level of the shower tray/bath and the showerhead (refer to illustration). This is to prevent back-siphonage. For further information on the installation of your Shower Fittings, refer to the Fittings Installation and User Guide.
- Note!** Only use Shower Fittings recommended by the manufacturer or supplier.

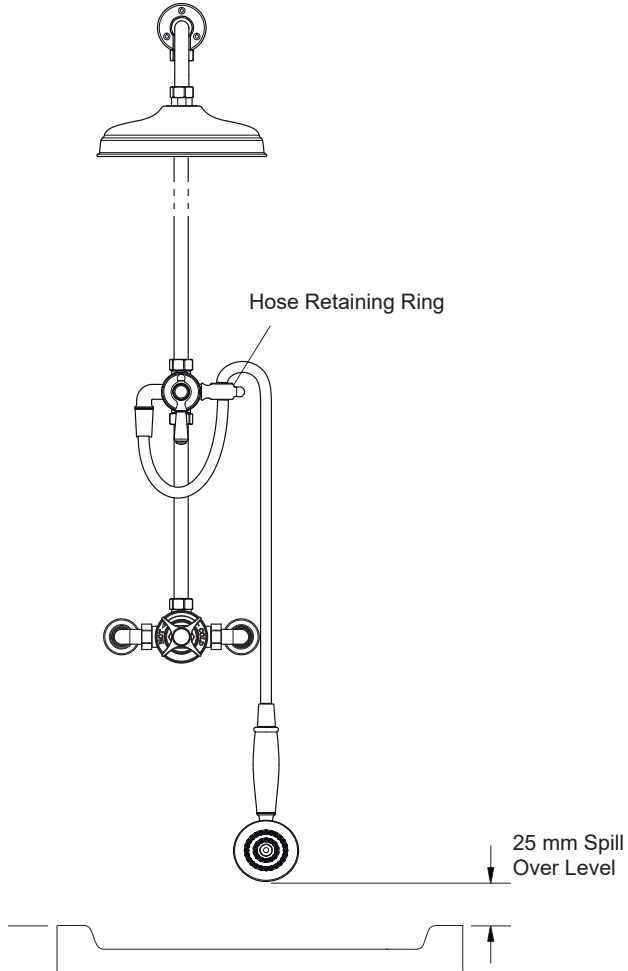

Flow Regulator Installation

Flow regulators are supplied with this product and should be fitted in High Pressure systems to either;

1. Reduce Excessive Force and Flow Rate
2. Reduce Noise through the mixer due to high or unequal pressures
3. Stabilise incoming supply temperatures

Installation of Mira Virtue Mixer

Warning! Isolate the water supplies before installing the shower.

1

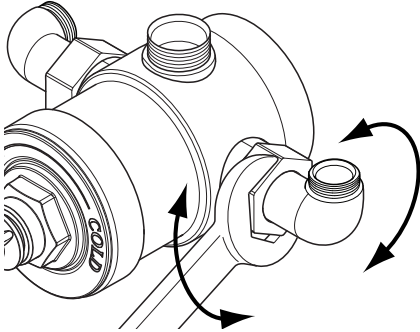

The thermostatic mixer can be installed with rear or falling supply inlets. Decide on the most appropriate method for your installation, and if necessary, the inlet elbows can be swivelled to suit.

Note! The Mira Virtue with Diverter cannot be installed with a falling supply.

2

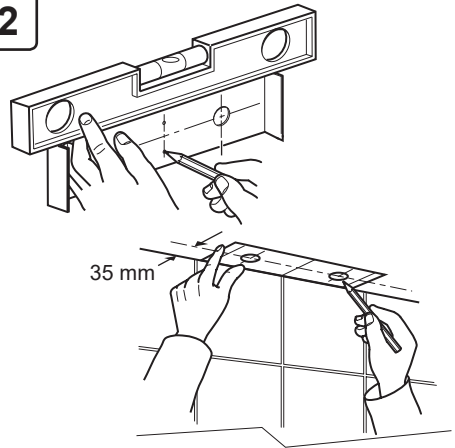

Use the installation template to mark the positions of the holes for the backplate and the pipe centres.

For rising or falling supplies the pipe positions should be set 35 mm from the centre of pipe to the finished wall at 153 mm centres.

3

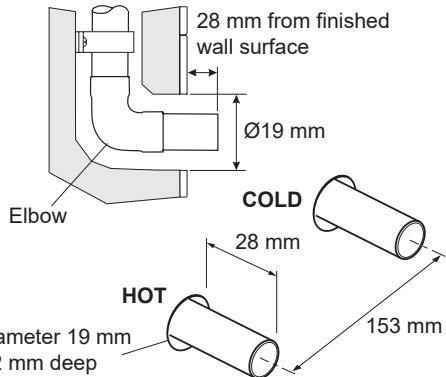
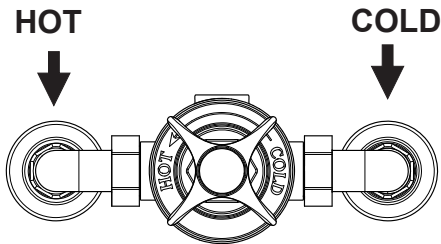

Fit the supply pipework: **Hot - Left, Cold - Right**. For rear entry supplies the inlet pipework should extend 28 mm from the finished wall surface, for rising or falling supplies the centre of the pipe should be set 35 mm from the finished wall surface.

Note! If it is not possible to install the mixer with this pipework configuration complete the installation then refer to section: '**Reversed Inlet Supplies**'.

4

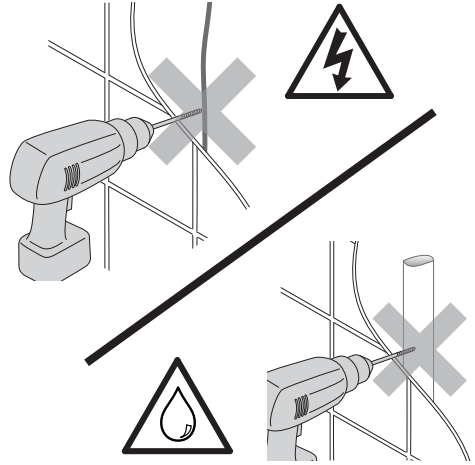
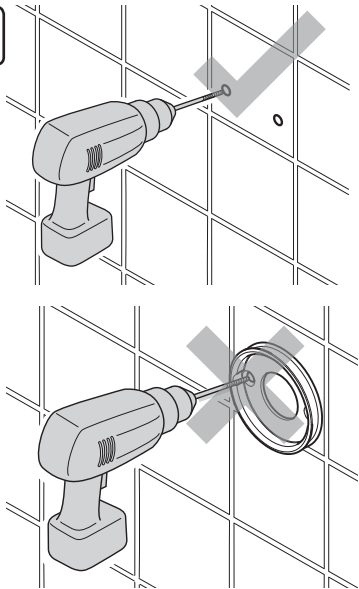

Ø6mm drill required for wall plugs supplied

For solid walls, drill the holes for the backplate with a 6 mm drill and insert the wall plugs.

Note! For other types of wall structure alternative fixings may be required (not supplied).

DO NOT drill through the backplate into the wall.

DO NOT drill into buried cables or pipes.

5

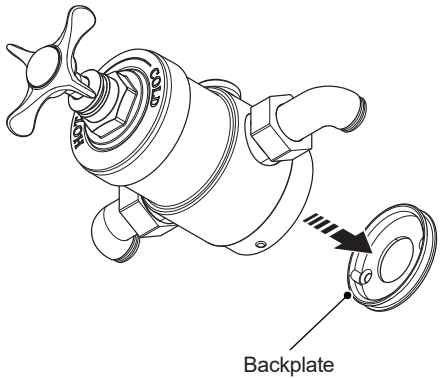
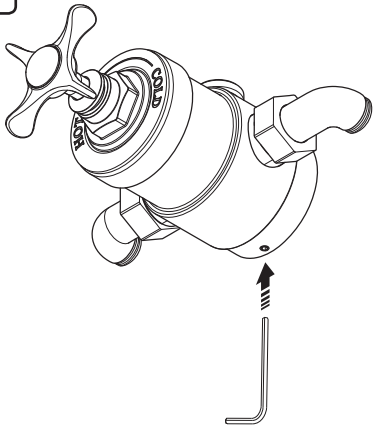

Remove the backplate from the mixer by loosening the grub screw with a 2.5 mm hexagonal key.

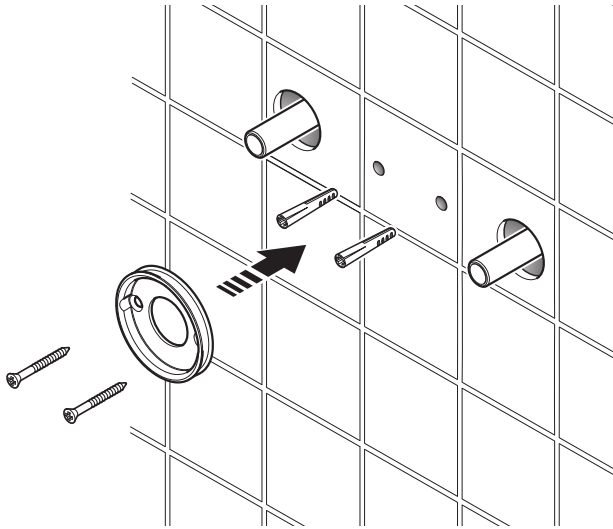
6

Fix the backplate to the wall, 2 x No. 8 x 1¼" screws and wall plugs are supplied.

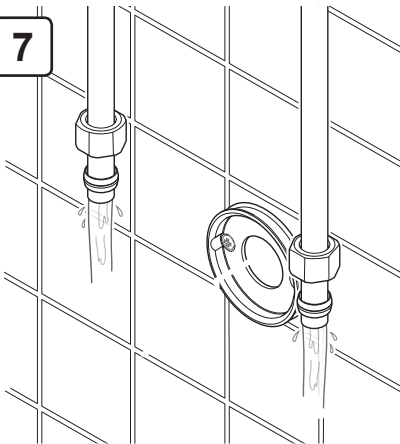
7

FALLING SUPPLIES

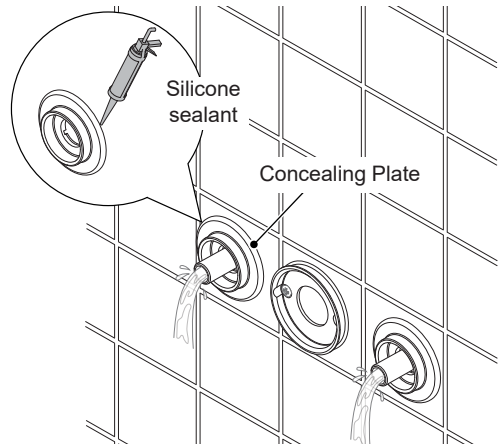

REAR SUPPLIES

For Rear Entry Supplies Only:

Note! Falling supplies are not suitable for Mira Virtue with diverter.

Fit the concealing plates over the inlet pipes.

Note! Apply silicone sealant to the back face of the concealing plate.

Flush the water supplies thoroughly before connecting the shower unit.

Caution! It is essential at this point that the supply pipework is thoroughly flushed through before connection to the mixer. Failure to do so may result in product malfunction and will not be covered under the guarantee.

8

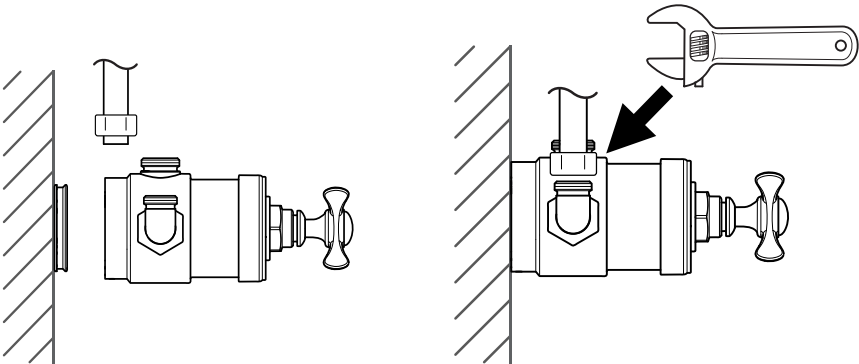
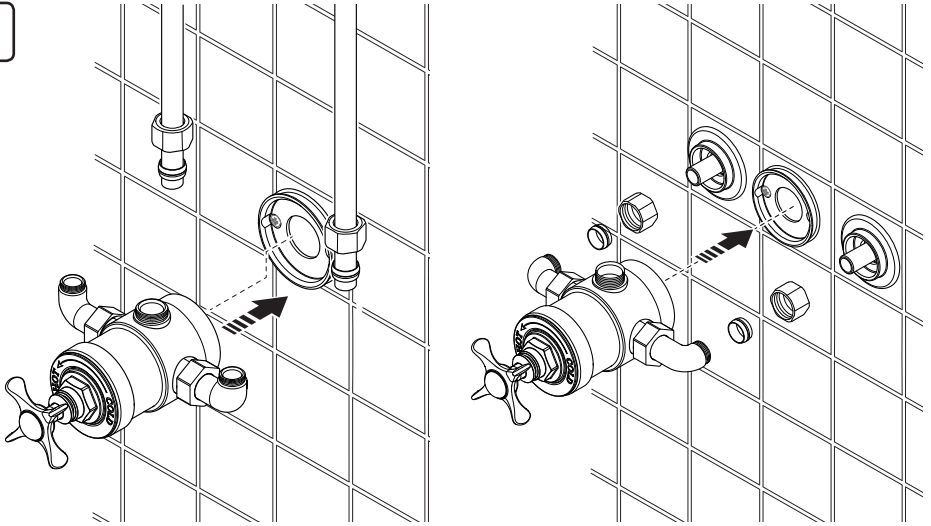

Fit the shower unit over the backplate and fix to the pipework. Avoid damage to the chrome finish when tightening the compression nuts.

9

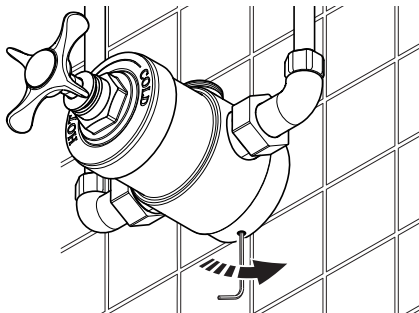

Tighten the grub screw to secure the mixer to the backplate. **DO NOT** overtighten the screw.

10 Installation of Shower Fitting

A. Mira Virtue

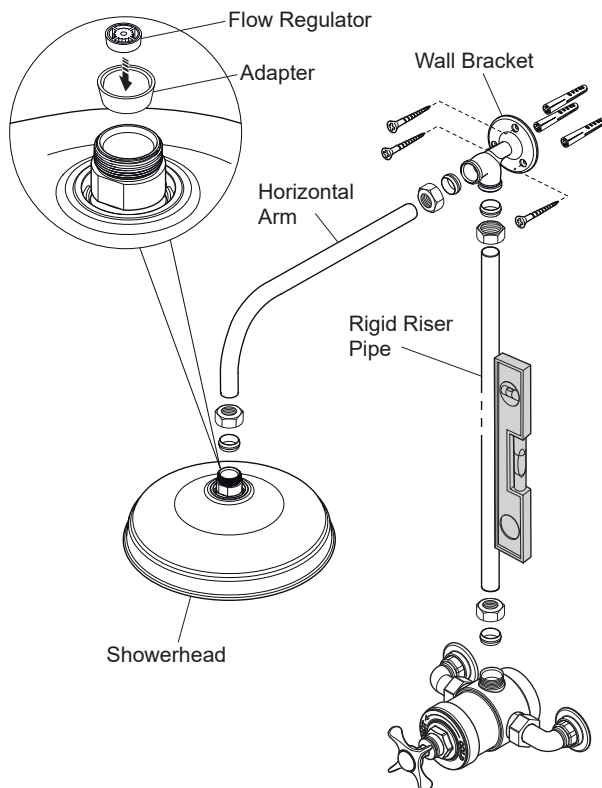

1. Temporarily fit the rigid riser pipe and wall bracket to the shower control outlet and mark the position of the wall bracket. Use a spirit level to ensure the pipe is vertical. Drill the holes and insert the wall plugs.

Note! The vertical rigid riser pipe can be shortened if required. De-burr the pipe ends before making the final connection.

2. Fix the wall bracket, rigid riser pipe, horizontal arm and tighten the three compression fittings on the shower control outlet and horizontal arm.

Note! Care must be taken when tightening compression nuts so that you do not damage the plated surfaces.

3. Turn on the hot and cold water supplies and check for leaks.
4. Thoroughly flush the outlet pipework before connecting the shower head. Slide the compression nut and olive over the horizontal arm and make the connection to the shower head.

Note! If fitting the flow regulator, make sure that it is fitted at this stage.

5. Before using the shower, refer to section: '**Commissioning**'.

B. Mira Virtue with Diverter

1. Refer to 'Mira Virtue, paragraphs 1 to 9' to install the mixer.

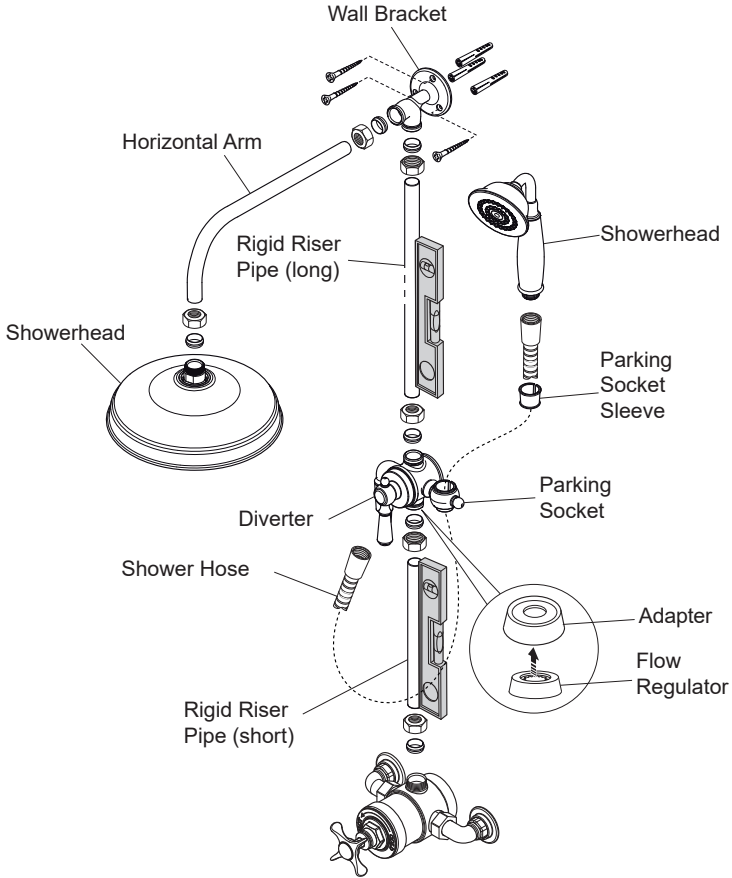

2. Temporarily fit the rigid riser pipe (short), diverter, rigid riser pipe (long) and wall bracket to the shower control outlet and mark the position of the wall bracket. Use a spirit level to ensure the pipes are vertical. Drill the holes and insert the wall plugs.

Note! If fitting the flow regulator, make sure that it is fitted at this stage.

Note! The vertical rigid riser pipes can be shortened if required. De-burr the pipe ends before making the final connection.

Note! The short and long riser pipes can be swapped around if the handset is required at a higher position.

3. Fix the rigid riser pipes, diverter wall bracket and tighten the four compression fittings on the shower control outlet. Fit the horizontal arm and tighten the compression fitting.
Note! Care must be taken when tightening compression nuts so that you do not damage the plated surfaces.
4. Turn on the hot and cold water supplies and check for leaks.
5. Thoroughly flush the outlet pipework before connecting the showerhead. Slide the compression nut and olive over the horizontal arm and make the connection to the shower head.
6. Connect the shower hose to the outlet of the diverter. Make sure that the hose washer is fitted.
7. Pass the hose through the parking socket.
8. Stretch the parking socket sleeve over the hose using the split. Squeeze the parking socket sleeve to fit it into the parking socket. Ensure the split is at the back and the tag is facing the diverter.
9. Connect the showerhead. Make sure that the hose washer is fitted.
10. Locate the showerhead in the parking socket.
11. Before using the shower, refer to section: '**Commissioning**'.

Reversed Inlet Supplies

The Mira Virtue thermostatic mixer is supplied with inlet connections **Hot - Left, Cold - Right** as standard. If the hot and cold water supply pipes have been reversed during installation the thermostatic cartridge must be removed and rotated 180°.

1. Isolate the hot and cold water supplies and operate the control lever to relieve pressure and drain any residual water.

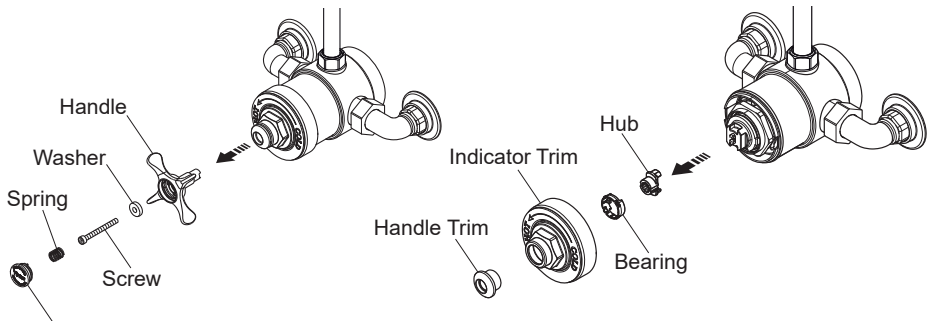

2. Make sure that the control lever is in the 'Off' position.
3. Press and rotate the ceramic bezel anticlockwise by 90° to remove.
Careful! There is a spring behind the ceramic bezel.
4. Using a 3mm allen key, remove the handle securing the screw and washer.
5. Pull off the handle trim along with indicator trim
Note! The indicator trim may be tight to pull off
6. Remove the bearing and hub from mixer.

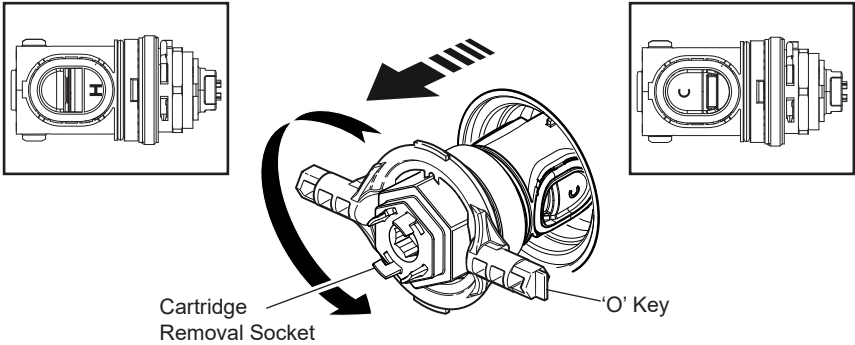

7. Fit the cartridge removal socket and 'O' Key (supplied) onto the cartridge nut and turn anticlockwise. Unscrew fully and pull the cartridge from the mixer body.
8. Rotate the Cartridge 180°.
9. Make sure that the two cartridge inlet seals are fitted and carefully push into the body, aligning the cartridge lugs into the body slots.
Note! Check that the cartridge lug stamped 'H' is aligned with the hot inlet supply.
Important! Take care when fitting the cartridge as damage to the cartridge inlet seals may result in dripping from the shower head.
10. Tighten the nut by turning the 'O' key and the cartridge removal socket clockwise.

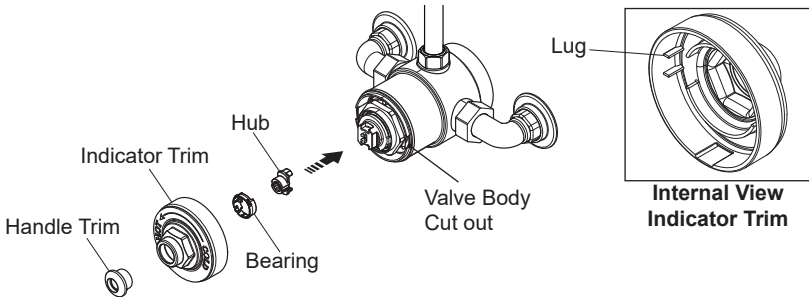

11. Refit the hub and bearing. Make sure that the hub is positioned fully clockwise.
12. Push on the indicator trim in the same orientation that you removed it. **Note!** Ensure the lugs on the inside of the indicator trim matches up with the cut outs on the valve body.
13. Refit the handle trim.

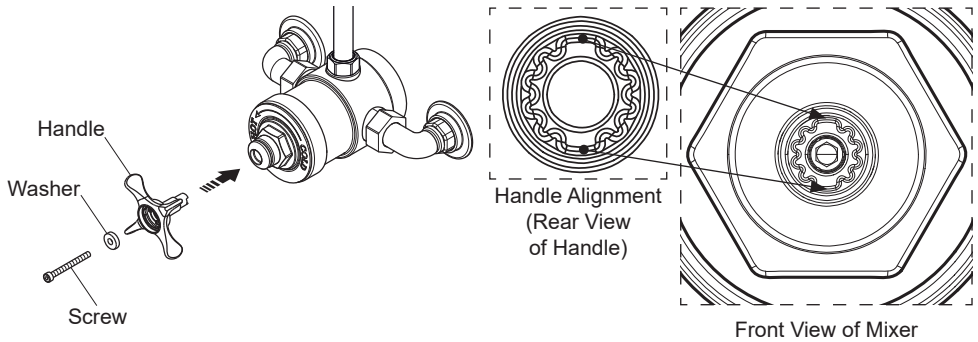

14. Fit the handle using the washer and screw.

Note! Make sure the washer is fitted as handle may come loose during use.

15. Tighten the screw to secure the handle.

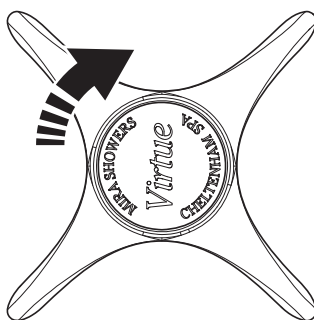
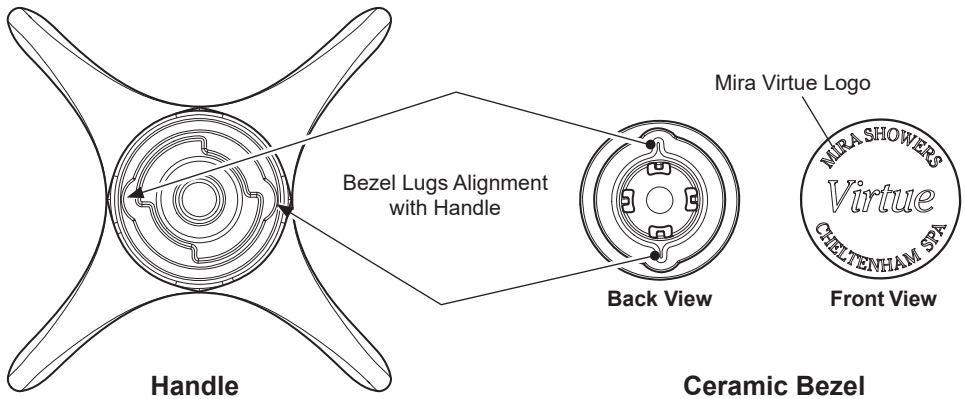

Installed Ceramic Bezel

16. Press and rotate the ceramic bezel clockwise by 90° to refit. **Careful!** There is a spring behind the ceramic bezel.

17. Check that the showering temperature is correct.

Commissioning

Maximum Temperature Setting

Before using the shower, the maximum temperature must be checked to make sure that it is at a safe level. It has been preset to a safe showering temperature under ideal conditions at the factory, appropriate for most systems. However, site conditions and personal preference may make it necessary to reset this temperature.

Note! Make sure that the hot water temperature is at least 55°C and that there is sufficient supply.

1. Turn on the shower to the maximum temperature (i.e. fully anticlockwise) and allow the temperature to stabilise. If the temperature is too hot or too cold, turn off the shower and adjust as follows:
2. Make sure that the control lever is in the 'Off' position.
3. Press and rotate the ceramic bezel anticlockwise by 90° to remove. **Careful!** There is a spring behind the ceramic bezel.
4. Using a 3mm allen key, remove the handle securing the screw and washer.
5. Remove the handle trim along with indicator trim.
6. Turn on the shower to the maximum temperature by rotating the hub fully anticlockwise and allow the temperature to stabilise.
7. Remove the bearing and hub from mixer.
8. Insert the 2.5 mm allen key into the centre of the spindle and engage with the recessed temperature adjusting screw.
9. Rotate the allen key until the required maximum temperature is obtained at the shower. Turn anticlockwise to increase the temperature, or clockwise to decrease the temperature ($\frac{1}{4}$ turn = approximately 1°C).
10. Once the desired maximum blend temperature has been achieved turn off the shower.

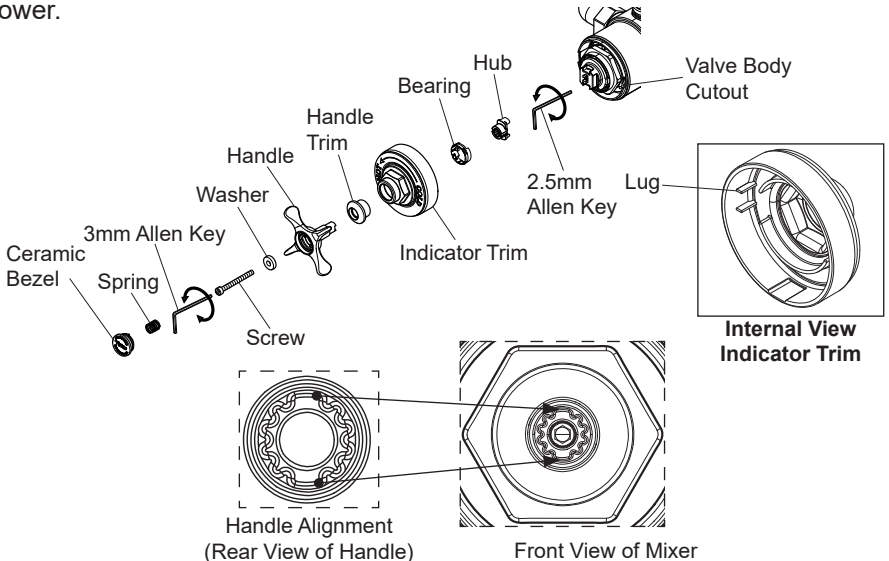

11. Refit the hub and bearing. Make sure that the hub is positioned fully clockwise.
12. Refit indicator trim in the same orientation that you removed it. **Note!** Ensure the lugs on the inside of the indicator trim matches up with the cut outs on the valve body.
13. Refit the handle trim.
14. Fit the handle using washer and screw. **Careful!** Ensure that washer is assembled when refitting the handle as this could lead to corrosion.
15. Tighten the screw to secure the handle.

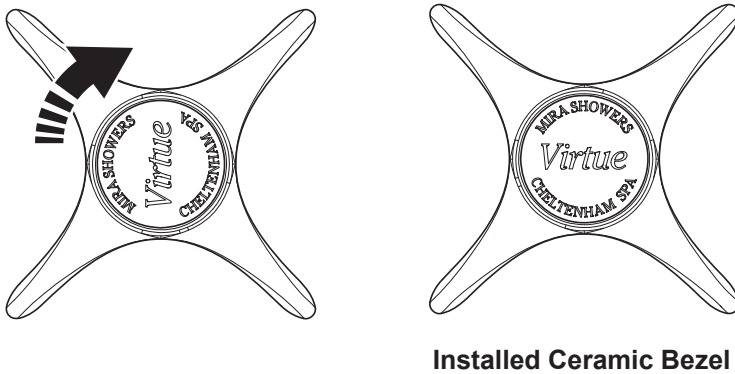
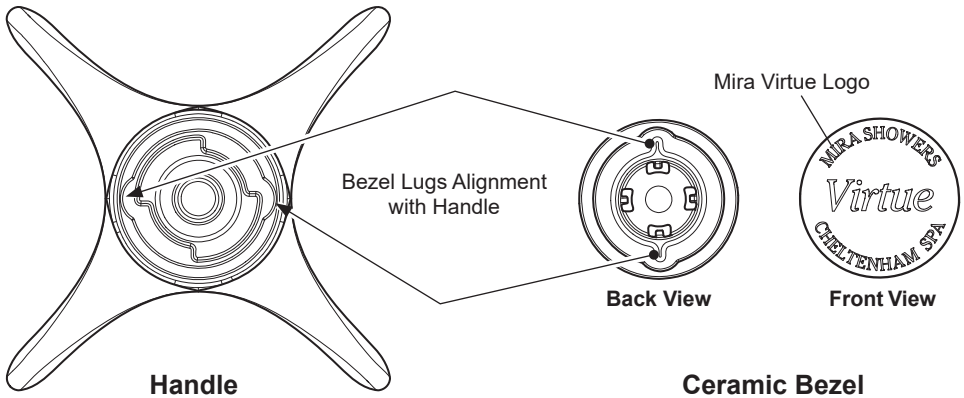

16. Press and rotate the ceramic bezel clockwise by 90° to refit. **Careful!** There is a spring behind the ceramic bezel.
17. Check that the showering temperature is correct.

Operation

Mira Virtue Mixing Valve

The Mira Virtue thermostatic mixer is a thermostatic shower control with a single control handle for on/off and temperature control.

The Control handle operates anti-clockwise in the following sequence:

- Off
- On
- Cold
- Hot
- Maximum Pre-set Temperature

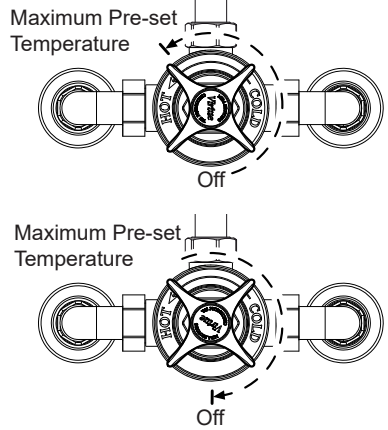

Mira Virtue with Diverter

The Mira Virtue thermostatic mixer is a thermostatic shower control with a single control lever for on/off and temperature control.

The Control Lever operates anti-clockwise in the following sequence:

- Off
- On
- Cold
- Hot
- Maximum Pre-set Temperature

The diverter lever operates as shown right:

- Control Lever Position 1 - Water comes out of the Overhead Shower.
- Control Lever Position 2 - Water comes out of the Handshower.
- Control Lever Position 3 - Water comes out of both the Overhead and the Handshower.

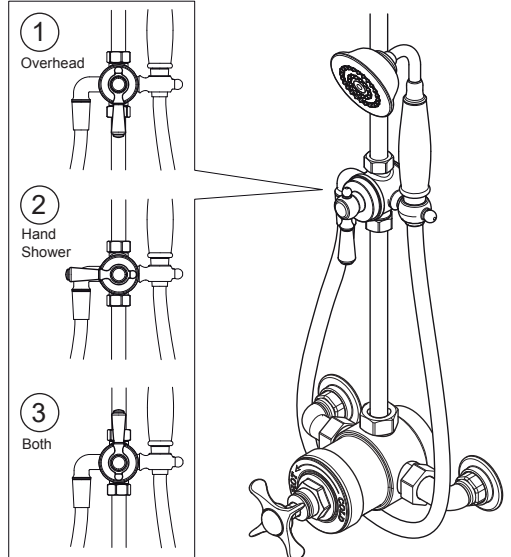

User Maintenance

General

This Product is precision engineered and should give continued safe and controlled performance, provided:

1. It is installed, commissioned, operated and maintained in accordance with manufacturers recommendations.
2. Periodic attention is given, when necessary, to maintain the product in good functional order.

The Mira Virtue thermostatic mixer is designed to need only minimal maintenance in normal use. The only serviceable parts are the inlet filters which should be checked and cleaned every 12 months. If a malfunction occurs with the thermostatic cartridge then this will necessitate a complete cartridge replacement.

Note! The cartridge contains no internally serviceable parts.

If you require a Mira trained engineer or agent, refer to section: '**Customer Service**'.

Lubricants

Silicone based lubricants must only be used on the rubber seals.

Caution! Oil based or other lubricant types may cause rapid deterioration of seals.

Cleaning

Many household and commercial cleaners, including hand and surface cleaning wipes contain abrasives and chemical substances that can damage plastics, plating and printing and should not be used.

Important! The showerhead must be descaled regularly. Keeping the shower spray clean and free from limescale will ensure that your shower continues to give the best performance.

Inlet Filters

The inlet filters should be checked and cleaned as necessary every 12 months.

Note! The inlet filters must not be removed except for cleaning. If the thermostatic mixer is operated without the inlet filters fitted the warranty on the product will be void.

1. Isolate the hot and cold water supplies and operate the control lever to drain any residual water.
2. Unscrew the grub screw securing the shower control to the backplate.

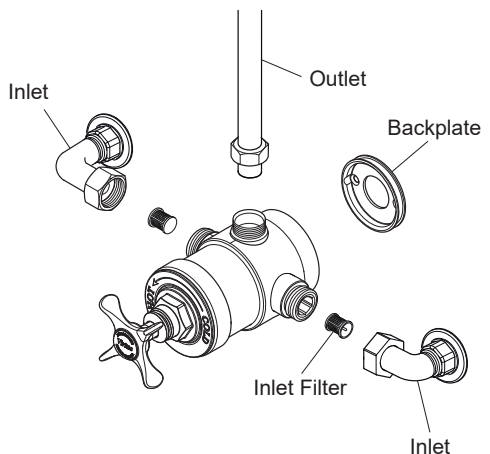

3. Unscrew the inlet and outlet connectors.
4. Remove the shower control.
5. Remove the filters.
6. Clean the filters under a jet of water to remove any lodged particles or replace them.
7. Reassembly is the reversal of the above procedure.
8. Turn on the hot and cold water supplies and check for leaks.

Mira Virtue with Diverter

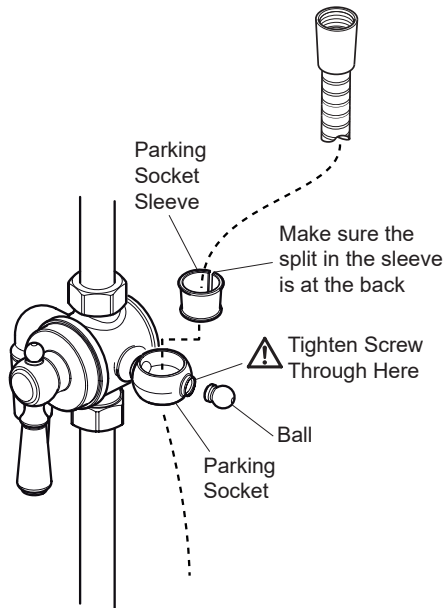

After a period of use the friction device on the parking socket may become loose, this can be tightened as follows:

1. Unscrew the ball.
2. Squeeze the parking socket sleeve together and pull out vertically.
3. Remove the parking socket sleeve from the hose.
4. Remove the hose, back through the parking socket.
5. Tighten the screw.
6. Refit all the components in reverse order.

Fault Diagnosis

Only use genuine Kohler Mira replacement parts.

If you require a Mira trained service engineer or agent, please see '**Customer Service**' on the back cover of this guide.

Symptom	Cause	Recommended Action
<p>Only hot or cold water from the mixer outlet.</p> <p>Outlet temperature too hot / too cold.</p>	<p>Inlets reversed (hot supply to cold supply).</p> <p>No hot water reaching mixer.</p>	<p>Check the filters for any blockage.</p> <p>Installation conditions outside operating parameters, refer to sections: 'Specifications' and 'Commissioning'.</p>
<p>Fluctuating or reduced flow rate.</p>	<p>Flow regulator fitted incorrectly.</p> <p>Air lock or partial blockage in the pipework.</p>	<p>Check the showerhead, hose and filters for any blockage and clean.</p> <p>Make sure that the maintained inlet pressures are nominally balanced and sufficient, refer to section: 'Specifications'.</p> <p>Make sure that the inlet temperature differentials are sufficient, refer to section: 'Specifications'.</p>
<p>Water leaking from showerhead.</p>	<p>Normal for a short period after shut off.</p>	<p>Check that the pressures are not in excess of the specifications for the product.</p> <p>Renew the thermostatic cartridge.</p>
<p>Shower noisy.</p>	<p>Water pressure high.</p> <p>Water pressure unequal.</p>	<p>Rectify water pressure problem.</p> <p>Renew Thermostatic cartridge</p>

Spare Parts

Mira Virtue

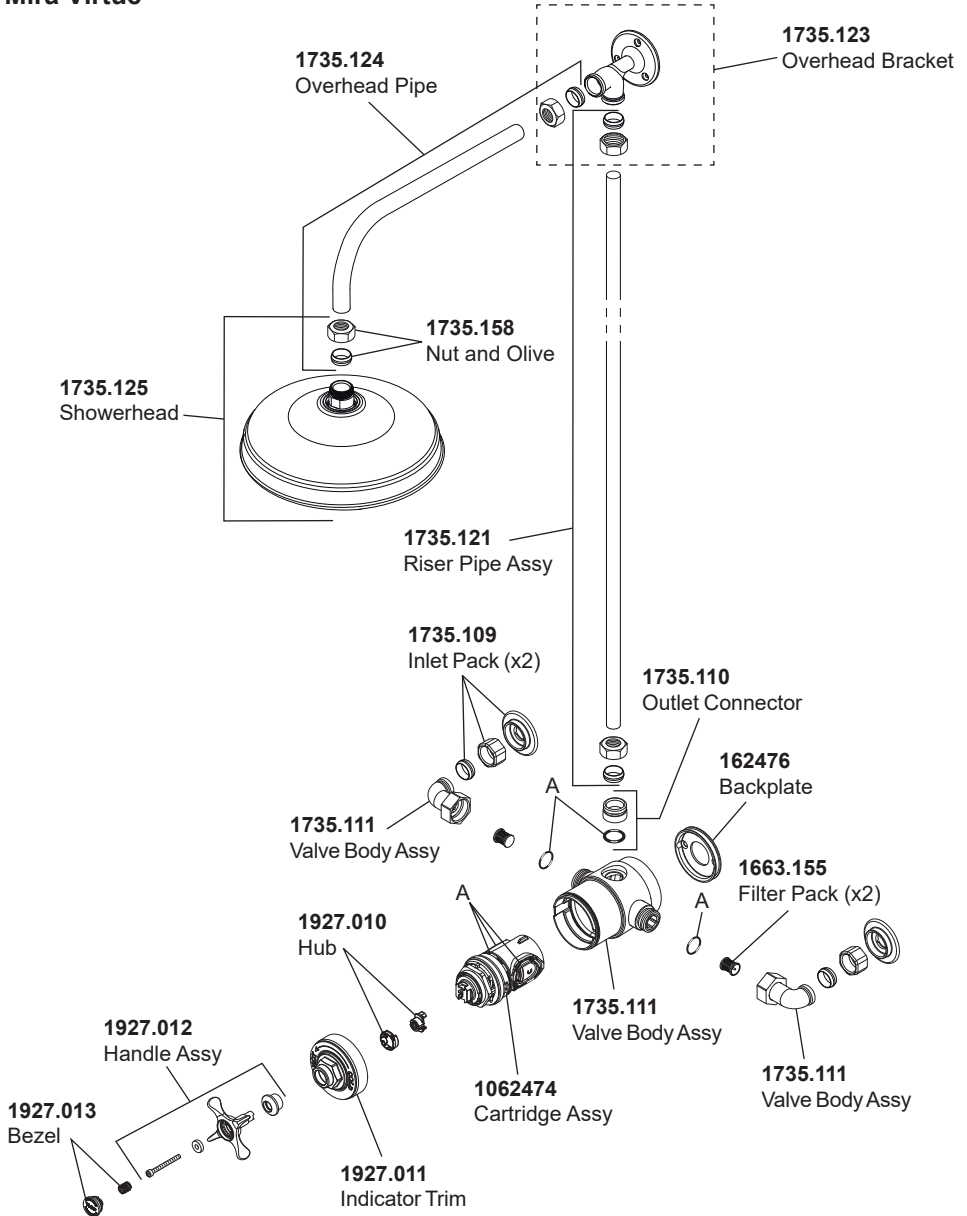

1735.114 Valve Seal Pack - Components Identified 'A'

1735.128 Screw Pack - Not Identified

1735.129 Component Pack - Not Identified (Includes Flow Regulator and Adaptor, Hose Sleeve and Wall Fixing Screws)

Mira Virtue with Diverter

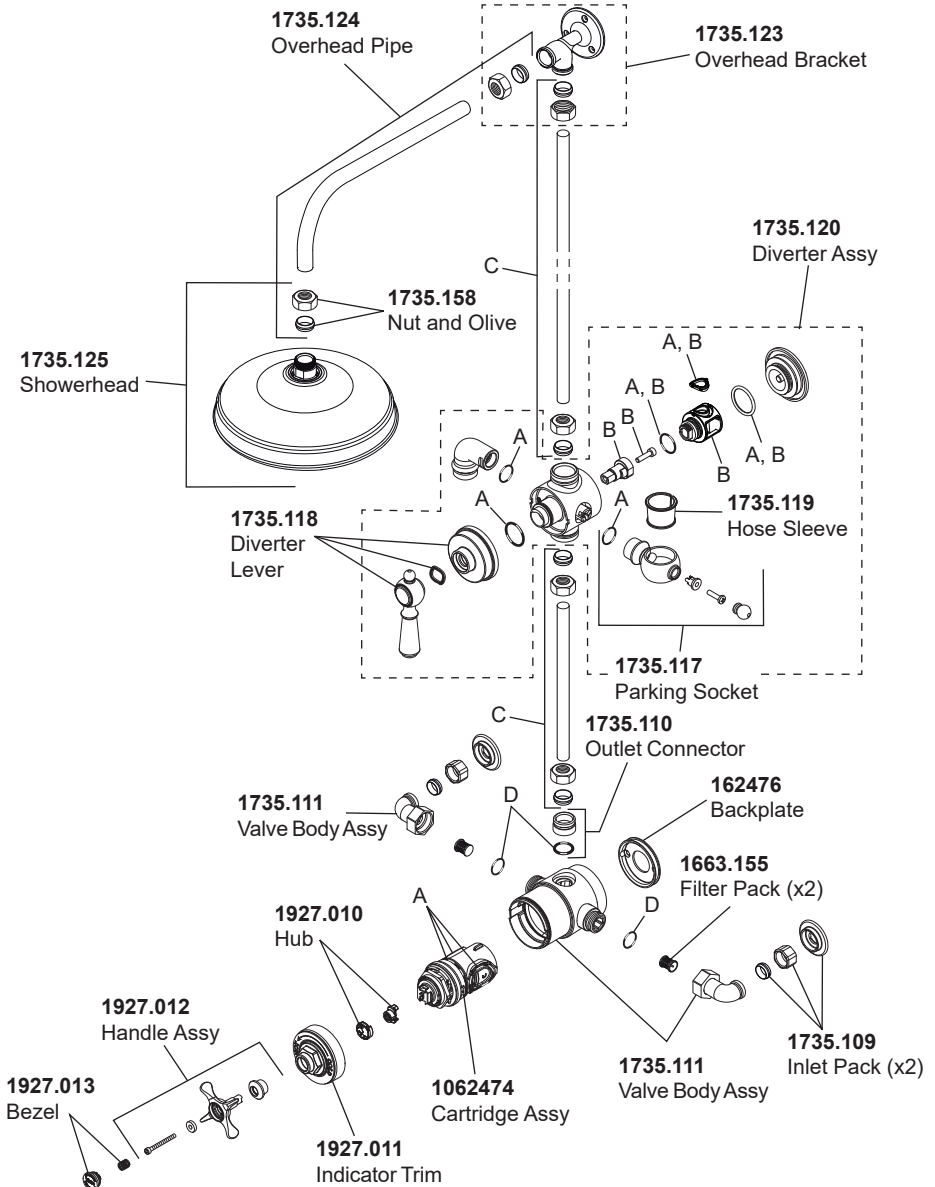

- 1735.115 Diverter Seal Pack - Components Identified 'A'
- 1735.116 Diverter Internals - Components Identified 'B'
- 1735.122 Riser Kit - Components Identified 'C'
- 1735.114 Valve Seal Pack - Components Identified 'D'
- 1735.128 Screw Pack - Not Identified
- 1735.129 Component Pack - Not Identified (Includes Flow Regulator and Adaptor, Hose Sleeve and Wall Fixing Screws)

Customer Service

Guarantee

Your product has the benefit of our manufacturer's guarantee which starts from the date of purchase. This guarantee only applies in the United Kingdom and Republic of Ireland. To activate this guarantee, please return your completed registration card, visit our website or free phone **0800 5978551** within 30 days of purchase (UK only).

Within the guarantee period we will resolve defects in materials or workmanship, free of charge, by repairing or replacing parts or product as we may choose.

This guarantee is in addition to your statutory rights and is subject to the following conditions:

- The guarantee applies solely to the original installation under normal use and to the original purchaser only. The product must be installed and maintained in accordance with the instructions given in this guide.
- Servicing must only be undertaken by us or our appointed representative.
Note! If a service visit is required the product must be fully installed and connected to services.
- Repair under this guarantee does not extend the original expiry date. The guarantee on any replacement parts or product ends at the original expiry date.
- For shower fittings or consumable items we reserve the right to supply replacement parts only.

The guarantee does not cover:

- Call out charges for non product faults (such as damage or performance issues arising from incorrect installation, improper use, inappropriate cleaning, lack of maintenance, build up of limescale, frost damage, chemical attack, corrosion, system debris or blocked filters) or where no fault has been found with the product.
- Water or electrical supply, waste and isolation issues.
- Compensation for loss of use of the product or consequential loss or indirect loss of any kind.
- Damage or defects caused if the product is repaired or modified by persons not authorised by us or our appointed representative.
- Routine maintenance or replacement parts to comply with the requirements of the TMV2 or TMV3 healthcare schemes.
- Accidental or wilful damage.
- Products purchased ex-showroom display.

What to do if something goes wrong

If your product does not work correctly refer to this guide for fault diagnosis and check that it is installed and commissioned in accordance with our instructions. If this does not resolve the issue, contact us for help and advice.



Helpdesk Service

Contact our Customer Service Team for product advice, to purchase spare parts or accessories or to request a service visit. You can contact us via phone or e-mail - contact details below. Please provide your model name, power rating (if applicable) and date of purchase.



Mira Showers Website

(www.mirashowers.co.uk)

Visit our website to register your guarantee, download user guides, diagnose faults, purchase our full range of accessories and popular spares, or request a service visit.



Spares and Accessories

We hold the largest stocks of genuine Mira spares and accessories. Contact us for a price or visit our website to purchase items from our accessory range and popular spares. (Only available in the United Kingdom.)



Service/Repairs

No one knows our products better than our nationwide team of Service Technicians. We carry out service or repair work to your product both during and after the guarantee period. (Only available in the United Kingdom and Republic of Ireland.) Ask about our fixed price service repairs.

To Contact Us: UK



0800 001 4040



01242 282595



Email - Visit

www.mirashowers.co.uk/contactus



By Post:

Mira Customer Services Dept, Cromwell Road,
Cheltenham, Gloucestershire, GL52 5EP

To Contact Us: Eire Only



01 531 9337



Email -

CustomerServiceEire@mirashowers.com

Mira is a registered trade mark of
Kohler Mira Limited.

The company reserves the right to alter
product specifications without notice.



FM 14648

mira
SHOWERS