

FLOAT SWITCH

OPERATING INSTRUCTIONS

**Please leave this instruction booklet with the pump as it contains maintenance and safety information
(Original Instructions)**

INDEX	Page No
Application	2
Product Description	3
Limits of Application	3
Technical Specifications	3
Typical Switch Installations	4
Pre-Assembly of Weights	6
Siting of the Switch & Installation	7
Electrical Installation	9
Maintenance	12
Storage	12

IMPORTANT NOTES



- **Please read these instructions fully before starting the installation:**
- **The installation must comply with the relevant water supply, electrical and building regulations and be installed by a competent person.**
- **If in doubt, consult Stuart Turner Ltd.**

APPLICATION

Stuart float switches are suitable for operation in most water based liquids and provide automatic control of electrically driven pumps of all types. They can be used for direct switching of small single phase motors with built in thermal overload protection. They can also be used to switch larger motors via a contact starter.



WARNING AGAINST MISUSE

- **This switch must not be used for any other application without the written consent of Stuart Turner Limited.**
- **This appliance is not intended for use by persons (including children) with reduced physical, sensory or mental capabilities, or lack of experience and knowledge, unless they have been given supervision or instruction concerning use of the appliance by a person responsible for their safety.**
Children should be supervised to ensure that they do not play with the appliance.

PRODUCT DESCRIPTION

The switch consists of a polypropylene casing, brass counterbalance weights, nylon float cord and polystyrene float.

The electrical contact is made using mechanical micro switches which are suitable for operation on voltages up to 250V AC. The switch operation is achieved by the rocking motion of the arm caused by the rise and fall of the float.

LIMITS OF APPLICATION

Maximum liquid temperature 50°C

Minimum liquid temperature 4°C

Maximum ambient air temperature 50°C

TECHNICAL SPECIFICATIONS

Model	Max Voltage	Current Rating		Type	Enc. Rating	Dims (Switch)			Dims (Float)		Gross Weight (packed) kg
		Resistive	Inductive			H	W	L	Dia	L	
F1 20/8	250V a.c.	20 amp	8 amp	Single Pole	IP22	59	56	132	63	125	0.6

Stuart Turner reserve the right to amend the specification in line with its policy of continuous development of its products.

TYPICAL SWITCH INSTALLATIONS

High level cut out (tank filling)

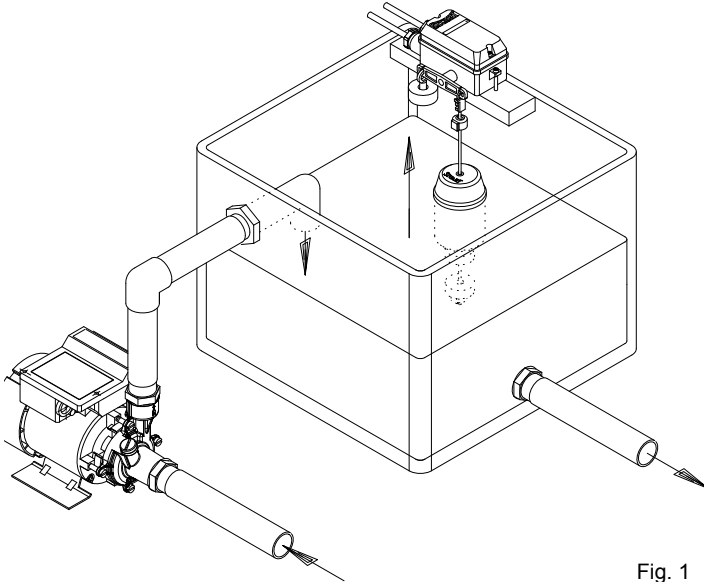

Fig. 1

Low level cut out (tank emptying)

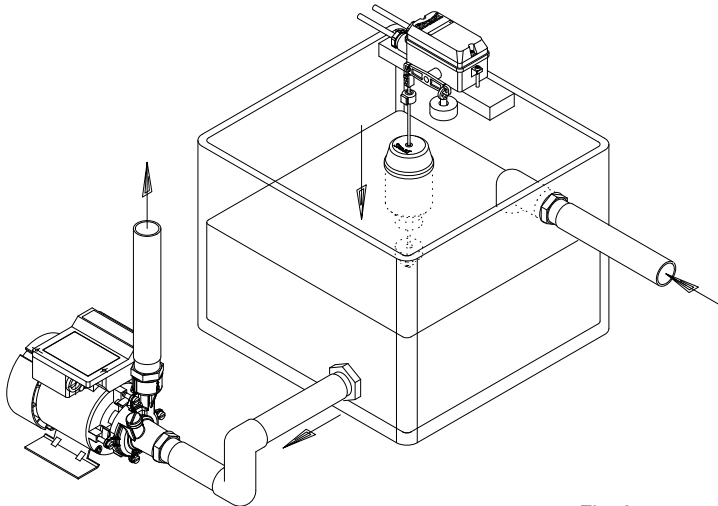

Fig. 2

NOTE : Different positions of float and counter balance, relevant to the operation the switch is required to carry out.

Cont ...

Two switch installation (providing low level cut out protection)

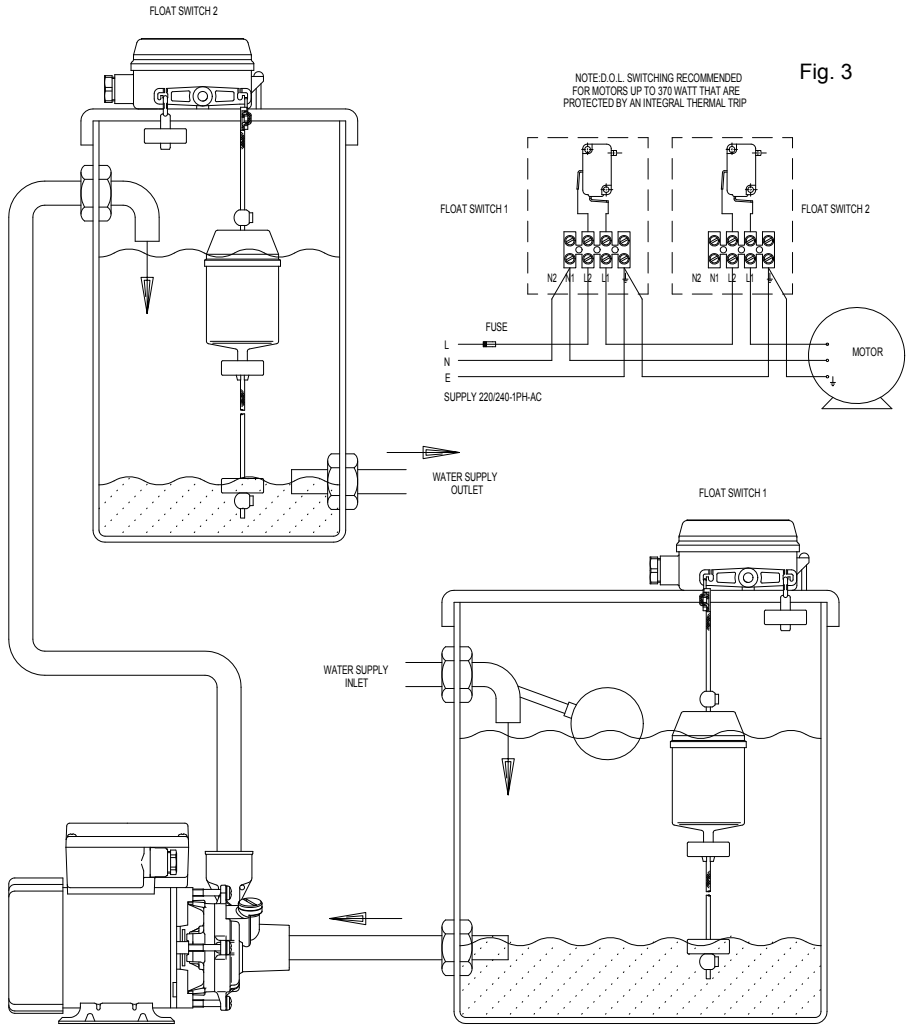

Fig. 3

Fig. 4

For installations where an erratic water supply can be a problem, two switches can be used as illustrated. Float switch 2 is controlling the start and stopping of the pump, whilst float switch 1 is providing low level protection by preventing the operation of the pump in the case of water shortage.

Cont ...

PRE-ASSEMBLY OF WEIGHTS

The switch assembly includes three weights, the position of which relative to the switch assembly is important for correct functionality of the switch.

- a) Counterbalance weight
This is the heaviest of the three (approx 112 g) and is pre-fitted at the factory as shown in Fig. 6.
If ever there is a need to remove or replace this weight, it must be re-fitted with the chamfer upwards as shown in Fig. 7.

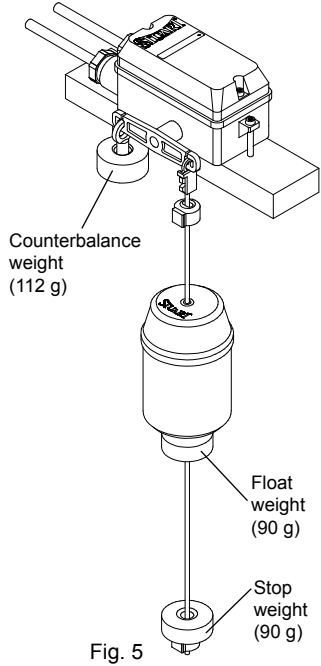
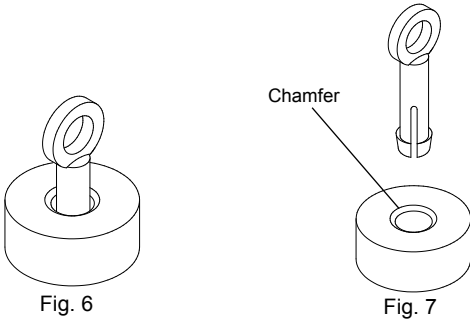

- b) Float weight and stop weight
These two weights are the same size (approx 90 g), are supplied loose and are interchangeable.
The float weight must be assembled to the float with the chamfer upwards as shown in Fig. 8.
The stop weight must also be assembled with the chamfer upwards as shown in Fig. 9.

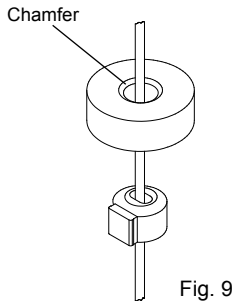
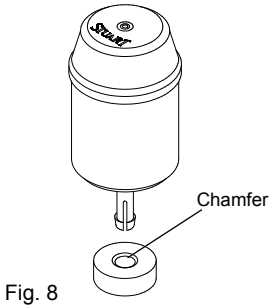

SITING OF THE SWITCH & INSTALLATION

WARNINGS:



- When used on a sump, make sure that it is kept clean. Aggressive mediums such as concrete dust and cinders may cause damage.
- When installing the main float switch casing ensure the mounting holes (to suit M4 screws) are used. Do not drill the switch casing as water ingress may subsequently occur which will damage the switch.



- Do not allow plastic parts to come into contact with oil or cellulose based paints, paint thinners or strippers, acid based descalents or aggressive cleaning agents.

The switch housing must be securely fixed in a horizontal position and should be protected from being sprayed with water. To permit free action of the switch, a sump should not be less than 20 cm diameter and at least 45 cm deep. This will permit a reasonable distance to be obtained between adjustment stops, which in turn will prevent constant stop / start conditions which could cause damage to motor. See sketch below for float operating range.

Float Operating Range

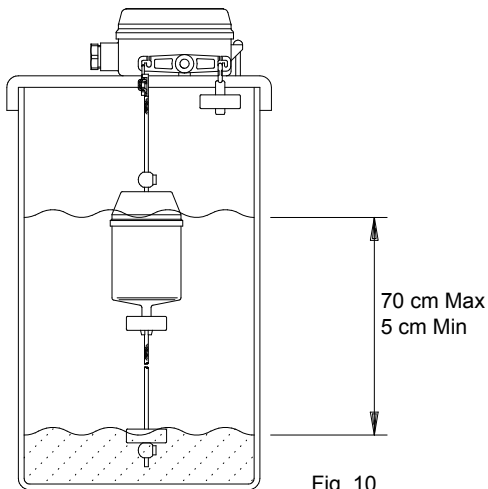

Fig. 10

Install unit so that the cord, float and the counterbalance weight cannot foul or rub against anything. The top of the float is marked 'TOP'. It is important to fit it the right way up. The float must slide easily up and down the cord. Control the movement of the float by adjusting the upper and lower level stops. Ensure that when in the lower position the float and stop weight are clear of the bottom of the sump or tank. The counterbalance operates the switch when the float lifts up the weighted cord. When the tank is emptied, the weighted cord plus float must overcome the counterbalance and operate the switch in the reverse direction. A 0.92 metre nylon cord is provided as standard.

To set switch for sump emptying:

For draining a sump (low level cut out) assemble the float on the left hand side of the operating lever (as shown in Fig. 11).

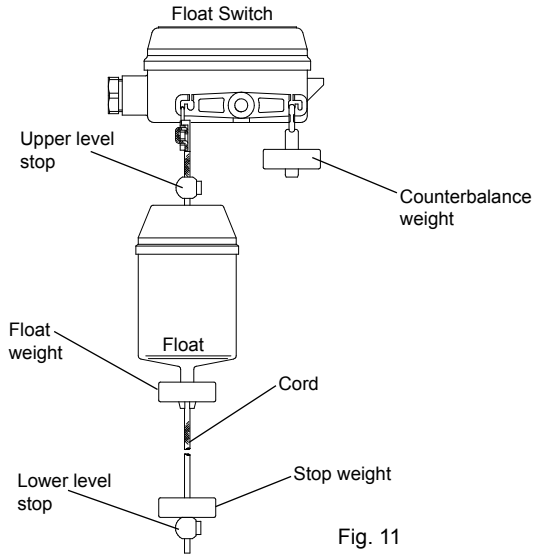

Fig. 11

To set switch for sump filling:

Assemble the float on the right hand side of the operating lever (as shown in Fig. 12). The pump will switch off when the tank is full.

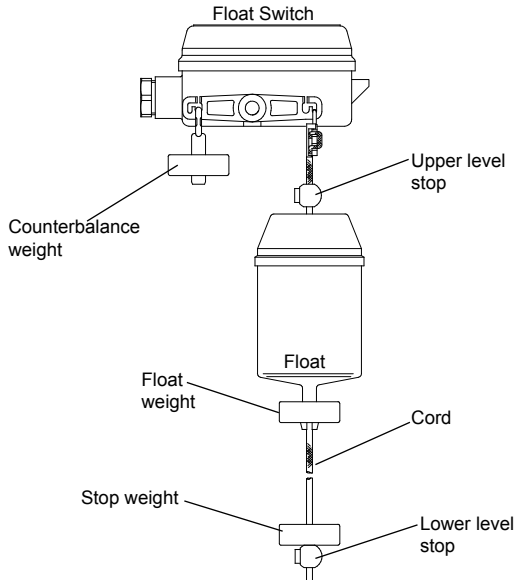
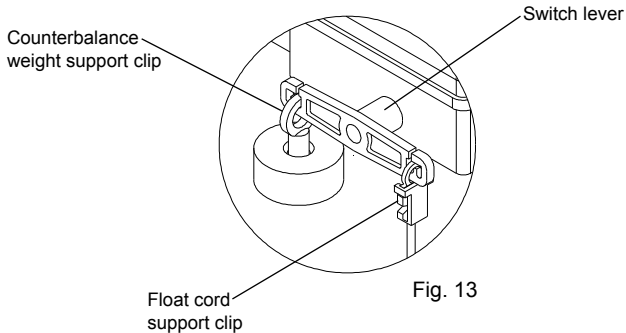

Fig. 11

Cont ...

To change function of switch:

To change the function of the switch from sump emptying to sump filling or vice versa, proceed as follows:-



The counterbalance weight and float assembly must be interchanged. This is done by manoeuvring both component support clips to the position where easy exit is provided on the switch lever. Re-assembly is the reversal of this procedure.

ELECTRICAL INSTALLATION

WARNINGS:



- **The electrical installation must be carried out in accordance with the current national electrical regulations and installed by a competent person.**
- **Before starting work on the electrical installation ensure the power supply is isolated.**
- **The switch and wiring must not be exposed to liquid.**
- **Do not operate switch without terminal box lid correctly fitted.**

The F1 switch is suitable for directly switching small output, single phase AC motors up to 370 watt (0.5 HP), providing the motors are fitted with integral thermal overload protection. Motors above 370 watt up to 750 watt (1HP) can also be directly switched, provided the motors are fitted with some means of overload protection and the motor full load current does not exceed the switch maximum (see technical specification section).

Larger single phase and three phase motors can be controlled by the switch via a contact starter. The starter should be fitted with hand reset thermal overload protection and the switch wired in series with the starter coil circuit (see wiring diagram section).

For installations in the United Kingdom, means for disconnection must be incorporated in the fixed wiring according to the Wiring Regulations.

Cont ...

Earthing



WARNING: Earthing continuity between the supply cords to and from the switch must be maintained.

The switch is provided with internal earthing terminals which are suitable for the connection of the earthing conductors within the flexible supply cords.

Wiring

The switch is provided with a set of terminals which allow the connection of flexible supply cords.

The supply cords should be of the PCP rubber insulated type (HO5RN-F) which is suitable for a wet environment. Cable and fuse size must be appropriately selected. For information on cable fitting consult the wiring diagrams and cable gland & supply cord fitting instructions.

Ensure the electrical connections are securely made and that the micro switch is connected in to the live line, not the neutral.

Cable Gland & Supply Cord Fitting Instructions (Single phase supply)

The cable gland assembly Fig. 15 (items 1 & 2) provides the necessary protection against ingress of solid objects and moisture as well as providing cable retention.

Assembly instructions are as follows: -

1. Ensure selected cable sheath diameter is within the permitted range (6.5 to 9.5 mm).
2. Strip and prepare the cable sheath and insulators as shown in Fig. 14.
3. Disassemble cable gland as shown in Fig. 15 and insert cable into position ensuring 'O'-ring (item 1) is placed over the cable before the clamping insert (item 2) is tightened.
4. Consolidate the stranded conductor ends by twisting.
5. Insert the phase, neutral and earthing conductors into the appropriate terminal block connections (see wiring diagram) and secure, ensuring all conductor strands are clamped.

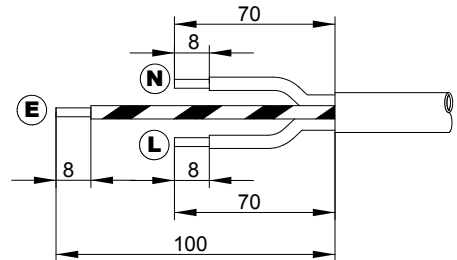

Fig. 14

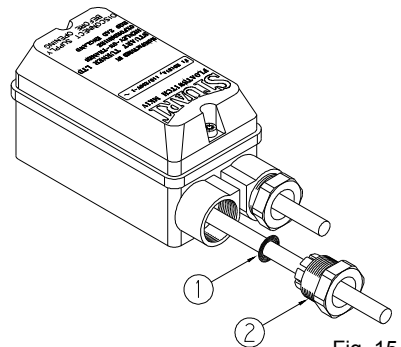
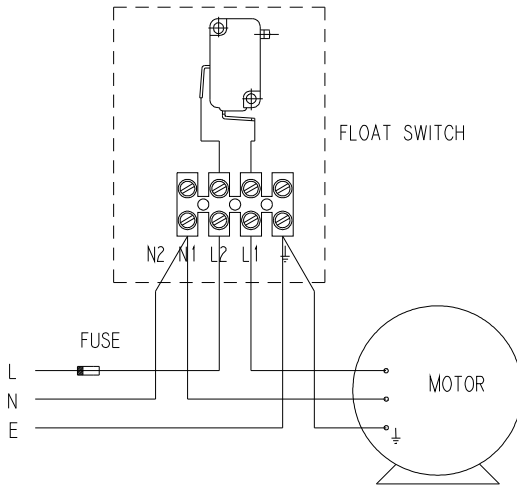

Fig. 15

Cont ...

Wiring Diagrams

NOTE: D.O.L. SWITCHING RECOMMENDED FOR MOTORS UP TO 370 WATT THAT ARE PROTECTED BY AN INTEGRAL THERMAL TRIP



WIRING DIAGRAM OF F1 MK4 FLOAT SWITCH D.O.L. SWITCHING OF SINGLE PHASE MOTOR

Fig. 16

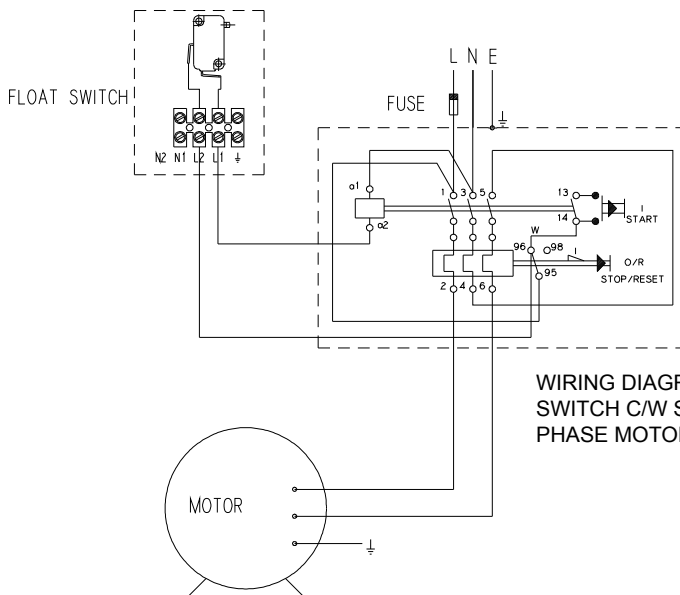

WIRING DIAGRAM OF F1 MK4 FLOAT SWITCH C/W STARTER AND SINGLE PHASE MOTOR

Fig. 17

Cont ...

Wiring Diagrams Cont.

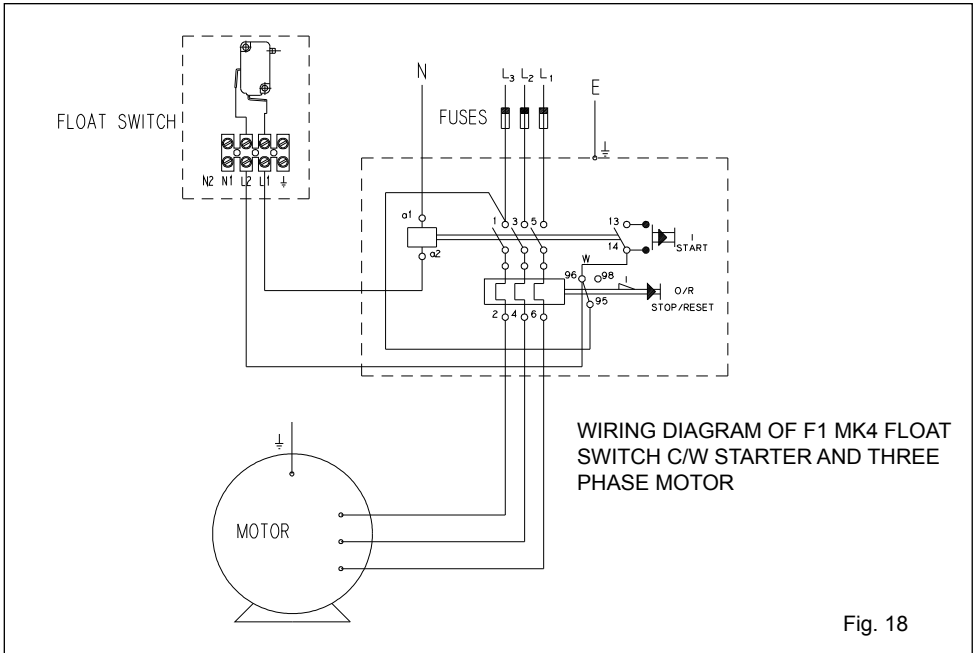

MAINTENANCE

1. No routine maintenance of the switch unit is required, although dependent upon conditions, a periodical clean of the float and cord should ensure trouble free operation.
2. Isolate electricity supply before attempting maintenance.

STORAGE

If this product is not installed immediately on receipt, ensure that it is stored in a cool dry place.

FOR FURTHER TECHNICAL SUPPORT

Phone the Stuart Turner Pump Assist team on +44 (0) 800 31 969 80. Our staff are trained to help and advise you over the phone or arrange for a service engineer to call.

Cont ...

YOUR 1 YEAR WARRANTY

Stuart Pumps are warranted by Stuart Turner Limited to be free from defects in materials or workmanship for the applicable warranty period from the date of purchase. The applicable warranty period is stated in the installation booklet supplied with the pump. Within the warranty period we will repair, free of charge, any defects in the pump resulting from faults in material or workmanship, repairing, exchanging parts or exchanging the whole unit as we may reasonably decide.

Not covered by this warranty: Damage arising from incorrect installation, improper use, unauthorised repair, normal wear and tear and defects which have a negligible effect on the value or operation of the pump.

Reasonable evidence must be supplied that the pump has been purchased within the applicable warranty period prior to the date of claim (such as proof of purchase or the product serial number).

This warranty is in addition to your statutory rights as a consumer. If you are in any doubt as to these rights, please contact your local Trading Standards Department or Citizen's Advice Bureau.

In the event of a claim please telephone Stuart Turner Limited on +44 (0) 800 31 969 80 or return your pump and flexible hoses with accessories removed, plugs, pipes etc. If you have any doubt about removing a pump, please consult a professional.

Proof of purchase should accompany the returned pump to avoid delay in investigation and dealing with your claim.

NOTES

Cont ...

NOTES

Cont ...



DECLARATION OF CONFORMITY



Electrical Equipment Regulations - 2016

EN 60335-1:2012/A2:2019, EN 60204-1:2018

EMF Regulations - 2016

EN 62233:2008

RoHS Regulations - 2012

EN IEC 63000:2018

Low Voltage Directive - 2014/35/EC

EN 60335-1:2012/A2:2019, EN 60204-1:2018

EMF Directive - 1999/519/EC

EN 62233:2008

RoHS Directive - 2011/65/EU

EN IEC 63000:2018

WEEE Directive - 2012/19/EU

IT IS HEREBY CERTIFIED THAT THE STUART ELECTRIC MOTOR DRIVEN PUMP AS SERIAL NUMBER BELOW, COMPLIES WITH THE ESSENTIAL REQUIREMENTS OF THE ABOVE STATUTORY REGULATIONS & E.U. DIRECTIVES.

[Large dashed rectangular box for serial number entry]

STUART TURNER LIMITED
HENLEY-ON-THAMES, OXFORDSHIRE
RG9 2AD, ENGLAND.

RESPONSIBLE PERSON AND MANUFACTURER

Signed.....

EU AUTHORISED REPRESENTATIVE

ARC (AUTHORISED REP COMPLIANCE)
GND FLOOR, 71 LOWER BAGGOT
STREET, DUBLIN,
D02 P593, IRELAND.

Stuart Turner are an approved company to BS EN ISO 9001:2015



Stuart Turner Ltd, Henley-on-Thames, Oxfordshire RG9 2AD ENGLAND

Tel: +44 (0) 1491 572655 Fax: +44 (0) 1491 573704

info@stuart-turner.co.uk | www.stuart-turner.co.uk