

EXE

Pressure compensating bath shower mixer



Installation and Operating Instructions

INSTALLERS PLEASE NOTE THESE INSTRUCTIONS ARE TO BE LEFT WITH THE USER

CONTENTS	Page
Introduction	1
Safety warnings	1
Main components	2
Site requirements	3
Typical suitable installations	4 – 5
Preparing the mixer valve	6
Siting of bath shower mixer	6
Installation	6 – 7
Leak testing	7
Fitting the fixed head showerhead holder	7 – 8
Hose and showerhead	8
Commissioning	8 – 9
Operating the bath shower mixer	9
Adjusting the showerhead	10
Cleaning	10
Spare parts	11
Fault finding	12 – 13
Guarantee, service policy, etc.	rear cover

To check the product suitability for commercial and multiple installations, please contact Triton's specification advisory service before installation.

Telephone: 0870 067 3767

Facsimile: 0870 067 3334

E mail: technical@tritonshowers.co.uk

INTRODUCTION

This book contains all the necessary fitting and operating instructions for your Unichrome Exe pressure compensating bath shower mixer.

Please read the instructions carefully. Read through the whole of this book BEFORE beginning your installation.

The mixer installation MUST be carried out by a suitably competent person and in sequence of this instruction book.

Care taken during the installation will provide a long and trouble free life from your mixer.

For best performance within the specified running pressure range a minimum flow of eight litres per minute should be available to both inlets.

The bath shower mixer MUST NOT be subjected to water temperatures above 80°C.

This mixer is designed for use with high pressure systems found in the UK up to a maximum of 5 bar running pressure.

IMPORTANT: When installing this mixer with a combination boiler or multi-point, flow limiters MUST be installed in the inlets. Please purchase either straight connectors (UNPIPCON) or bar bracket (UNBMXBKT).

The mixer is suitable for fully modulating type combination boilers and multi-point hot water heaters. It is also suitable for thermal storage and unvented systems.

IMPORTANT: Before installing with a gas instantaneous water heater, make sure it is capable of delivering hot water at a minimum switch-on flow rate of 3 litres per minute. At flow rates between 3 and 8 litres per minute, the appliance must be capable of raising the water temperature to a minimum of 52°C. Water temperature at the inlet to the mixer must remain relatively constant when flow rate adjustments are made (*refer to the water heater operating manual to confirm compatibility with this mixer*).

This mixer is supplied with an integral single check valve and integral filter in each inlet. The bath pillars inlet connections are to 3/4" BSP tap connector fittings (not supplied).

SAFETY WARNINGS

WARNING!

Please be aware that the Exe bath shower mixer is NOT thermostatic and will not prevent water flowing from the showerhead should there be a loss of one supply to the mixer inlets.

- a Layout and sizing of pipework must be such that when other services are used, pressures at the mixer control inlets **DO NOT fall below the recommended minimum.**
- b **DO NOT choose a position where the bath shower mixer could become frozen.**
- c **DO NOT connect this mixer to any form of tap or fitting not recommended by the manufacturer.**
- d The showerhead must be regularly cleaned to remove scale and debris.
- e Conveniently situated service valves in each inlet supply must be fitted as an independent method of isolating the mixer should maintenance or servicing be necessary.
- f If it is intended to operate the mixer in areas of hard water (above 200 ppm temporary hardness), a scale inhibitor may have to be fitted. For advice on the Triton scale inhibitor, please contact Customer Service.
- g **Do not operate the mixer outside the guidelines as laid out in 'site requirements'.**

Replacement parts can be ordered from Triton Customer Service. See 'spare parts' for details and part numbers.

Due to continuous improvement and updating, specification may be altered without prior notice.

COMPONENTS



- 1 Exe pressure compensating mixer valve
- 2 Bath pillars
- 3 Showerhead (not shown)
- 4 Showerhead holder (not shown)



SITE REQUIREMENTS

The installation must be in accordance with Water Regulations and Byelaws.

Running water pressure:

Mains fed – 1.0 bar min. to 5.0 bar max.

Maximum static water pressure:

Mains – 10 bar

DO NOT connect the mixer to a gravity hot supply and a mains cold supply (or vice versa).

For best shower performance within the specified running pressure range a minimum flow of eight litres per minute should be available to both inlets.

While the mixer is operational (open outlet), inlet pressures must not be capable of exceeding 7 bar. For effective operation of the internal seals, the maximum static pressure must not be exceeded.

Note: On sites where the running pressure is above 5 bar, the use of a suitably sized pressure reducing valve fitted in the cold mains supply pipework can provide nominally equal pressures at the bath shower mixer.

The pipework should be installed such that the flow is not significantly affected by taps and other appliances being operated elsewhere on the premises.

Where thermal store systems and instantaneous gas water heaters are used, if excessive draw-offs take place the boiler may not be able to maintain an adequate output temperature. This could result in the shower temperature becoming noticeably cooler.

Water temperature requirements

Maximum hot water temperature = 80°C

Recommended maximum = 65°C

Minimum hot water temperature = 52°C

Maximum cold water temperature = 20°C

BS 6700 recommends that the temperature of stored water should never exceed 65°C.

A stored water temperature of 60°C is considered sufficient to meet all normal requirements and will minimise the effects of scale in hard water areas.

Temperature adjustment range

The mixed water temperature can be adjusted from cold through to a top limit which can be preset during installation.

Fig.2 (diagrammatic view – not to scale)

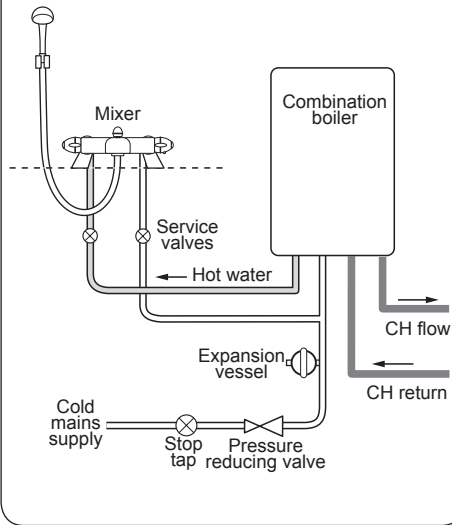

TYPICAL SUITABLE INSTALLATIONS

a) Instantaneous gas-heated systems, e.g. combination boilers (fig.2)

The mixer control **MUST** be installed with a multipoint gas water heater or combination boiler of a fully modulating design (i.e. to maintain relatively stable hot water temperatures).

A drop tight pressure reducing valve **MUST** be fitted if the supply pressures exceed 5 bar running.

An expansion vessel (shown in **fig.2**) **MUST** be fitted, and regularly maintained, to prevent the mixer being damaged by excess pressures. This may already be installed within the boiler (check with manufacturer) and is in addition to the normally larger central heating expansion vessel.

The layout and sizing of pipework **MUST** be such that nominally equal inlet supply pressures are achieved and the effects of other draw-offs are minimised. The hot supply temperature **MUST** remain a minimum of 10°C hotter than the required blend temperature for best performance.

b) Unvented mains pressure systems (fig.3)

The mixer control can be installed with an unvented, stored hot water cylinder.

For systems with no cold water take off after the appliance reducing valve, it will be necessary to fit an additional drop tight pressure reducing valve when the mains pressure is over 5 bar.

The drop tight pressure reducing valve must be set at the same value as the unvented package pressure reducing valve.

Note: An additional expansion vessel (as shown in **fig.3**) may be required if a second pressure reducing valve is installed. This does not apply to packages with a cold take off after the pressure reducing valve to the cylinder.

The layout and sizing of pipework **MUST** be such that nominally equal inlet supply pressures are achieved and the effects of other draw-offs are minimised.

Fig.3 (diagrammatic view – not to scale)

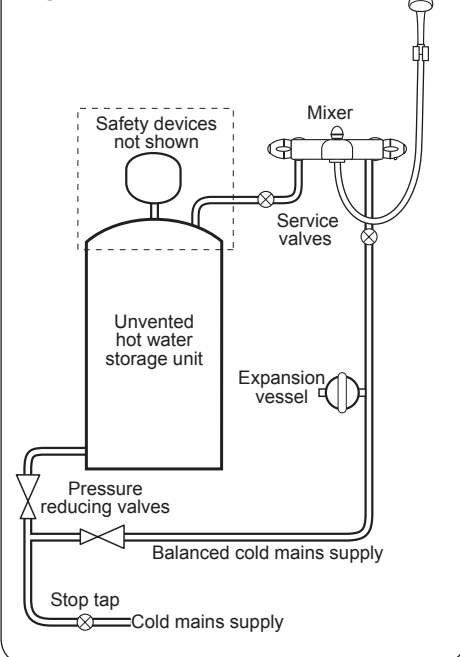

c) Mains pressurised thermal store systems (fig.4)

Packages of this type, fitted with a tempering valve (blender valve) can be used. A drop tight pressure reducing valve **MUST** be fitted if the supply pressures exceed 5 bar running.

An expansion vessel (shown in **fig.4**) **MUST** be fitted, and regularly maintained, to ensure the unit is not damaged by excess pressures. This may already be installed externally or internally within the thermal store (check with thermal store manufacturer).

Instantaneous water heater appliance capabilities

In order to provide the best performance from the shower when connected to an instantaneous water heater, the appliance must be capable of raising the temperature of the incoming water to a minimum of 52°C (125°F) and delivering a flow rate of not less than eight litres per minute.

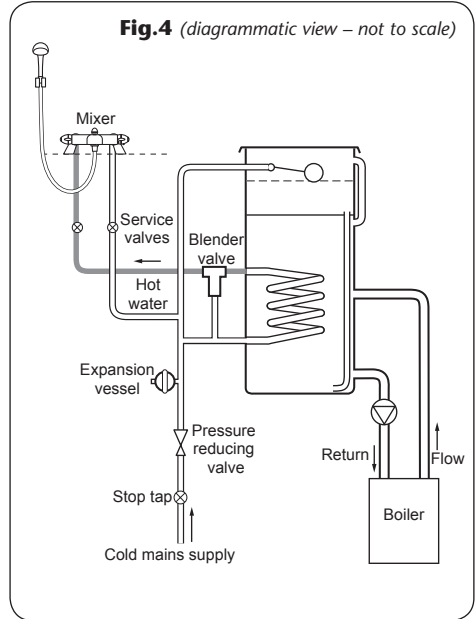
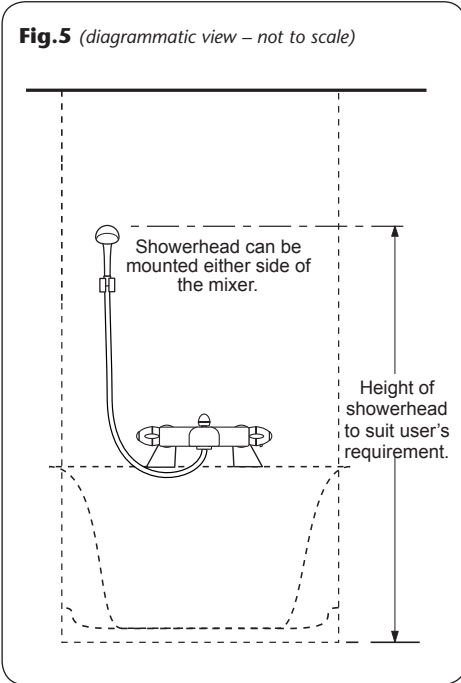

Fig.5 (diagrammatic view – not to scale)



WARNING!

Check there are no hidden cables or pipes before drilling holes for wall plugs. Use great care when using power tools near water. The use of a residual current device (RCD) is recommended.

PREPARING THE MIXER VALVE

Check the contents to make sure all parts are present.

Before starting the installation, make sure all the openings on the valve are carefully covered to prevent ingress of any debris, etc. while routing the supply pipework.

The bath shower valve comes supplied with fittings for installation onto a bath.

The hot water inlet has a red symbol next to the inlet and is on the left-hand side.

SITING OF THE BATH SHOWER MIXER

Refer to (fig.5) for correct siting of the mixer.

The showerhead can be positioned either side of the mixer unit.

WARNING!

The mixer must not be positioned where it will be subject to freezing conditions.

INSTALLATION

Note: The outlet of the bath shower mixer must not be connected to anything other than the showerhead supplied. **DO NOT use jointing compounds on any pipe fittings for the installation. DO NOT solder fittings within the vicinity of the mixer unit as heat transfer can damage the seals and thermostatic components.**

Note: Suitable service valves (complying with Water Regulations and Byelaws) MUST be fitted on the hot and cold water supplies to the shower as an independent means of isolating the water supplies should maintenance or servicing be necessary.

When connecting the pipework, avoid using tight 90° elbows. Swept or formed bends will provide the best performance.

IMPORTANT: Water Regulations require that where the showerhead can be lowered into the bath a double check valve or similar device MUST be fitted in the supply pipework to prevent back siphonage.

The inlet centres on the shower valves are 150mm and the inlet centres on the bath pillars are 180mm apart (**fig.6**).

Flush out the pipework in accordance with Water Regulations and Byelaws.

Insert the left-hand side pillar into the bath top, making sure the sealing washers are in place. Secure in place with the locking nut. Repeat the process for the right-hand side pillar. Check the inlet centres are correctly aligned for the mixer valve.

Offer the mixer valve to the bath pillars and, checking the sealing washers are in place, screw the unions into the fittings.

Connect pipework to the pillars using standard $\frac{3}{4}$ " BSP tap connector fittings (**fig.7**).

LEAK TESTING

Fit the hose to the outlet and direct it to waste.

Open the supplies and test for leaks in the valve connections. Remedy any leaks if necessary.

FITTING THE FIXED SHOWERHEAD HOLDER

Decide the position for the showerhead holder on the wall within the bath shower area.

Proceed as follows:

Hold the showerhead holder mounting plate in a suitable position on the wall. Using the plate as a template, mark two locating holes (**fig.8**). Drill and plug the wall. (The wallplugs provided are suitable for most brick walls – use an appropriate masonry drill, but if the wall is plasterboard or a soft building block, use special wallplugs and a suitable drill bit).

Replace the mounting plate and secure using the fixing screws supplied.

Slide the showerhead holder down onto the mounting plate (**fig.9**) until it clicks into place.

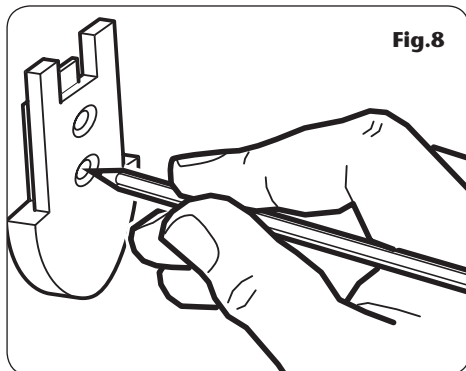
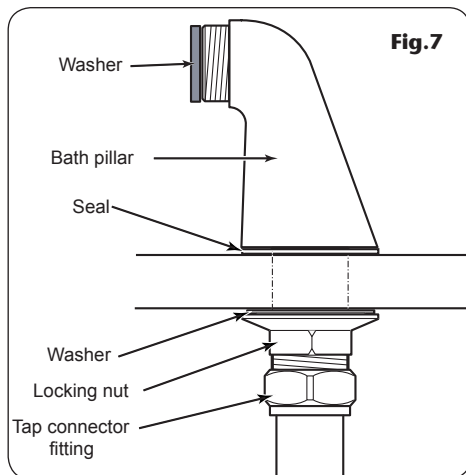
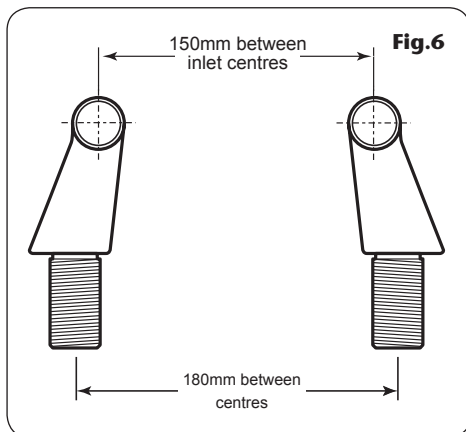
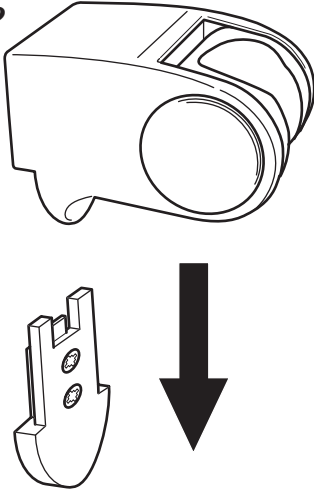

Fig.9



FITTING THE HOSE AND SHOWERHEAD

Screw the flexible hose to the shower outlet and showerhead. Make sure the supplied washers are in place at both ends of the flexible hose before fitting (**fig.10**).

Place the showerhead into the holder and check that it fits correctly.

Note: The holder is slightly tapered and the showerhead and hose will only fit from one direction.

IMPORTANT: It is the conical end of the hose which grips into the holder. The showerhead will not fit in the holder without the hose attached.

COMMISSIONING

Make sure that both hot and cold water supplies are fully open and at (or near to) their design temperature and pressures and are within the requirements as stated.

Check the temperature knob (right-hand side) is rotated fully anti-clockwise to the maximum temperature setting and the showerhead is directed to waste.

Start the water flow by turning the flow control (left-hand side) anti-clockwise.

Allow the mixer to run at the maximum temperature setting until the water temperature has stabilised. Using the temperature control knob, rotate until your desired maximum showering temperature is reached.

The mixer valve is fitted with a maximum temperature override button factory set at 40°C.

The mixer valve is factory set to provide a maximum outlet temperature of 40°C but this should be checked on site to make sure the setting has not been altered and also to ensure user safety.

To adjust the maximum temperature override setting

Remove the temperature control knob by removing the end cap and unscrewing the retaining screw (**fig.11**).

Turn the flow control fully anti-clockwise. With

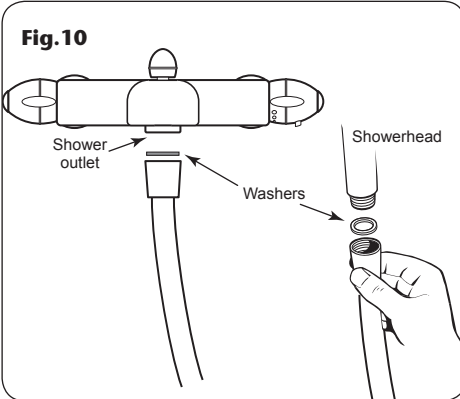

a steady flow running, adjust the temperature valve spindle (**fig.12**) until the temperature is about 38°C (turn right for cold and left for warm).

When you are satisfied with the temperature turn the flow control off. Refit the temperature control knob, checking that the temperature stop aligns with the reference dot on the mixer body. Secure with the screw and replace the end cap.

OPERATING THE BATH SHOWER MIXER

To start the mixer, rotate the On/Off flow control (left-hand side) fully anti-clockwise for maximum flow.

To stop the water flow, rotate the On/Off flow control fully clockwise.

To adjust the water temperature, rotate the temperature control (right-hand side) – clockwise for cool or anti-clockwise for hot.

To overcome the maximum temperature stop, press the red button on the temperature control and rotate.

Using the shower setting

To use the shower setting pull up and turn the diverter knob to lock it open (**fig.13**). To return to the tap setting pull and turn the knob to allow the diverter to drop down (**fig.14**).

CAUTION: Exposed metal surfaces may become hot during use.

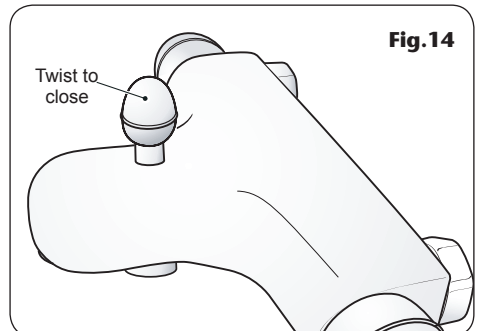
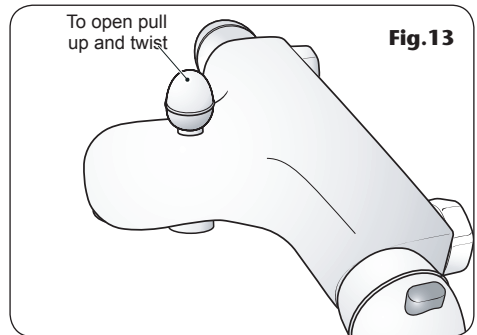
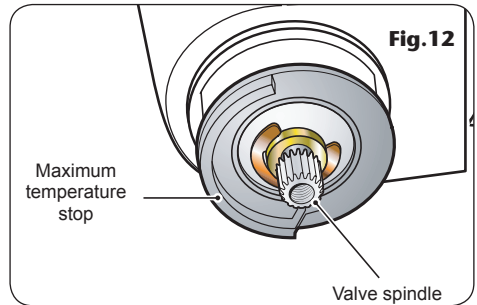
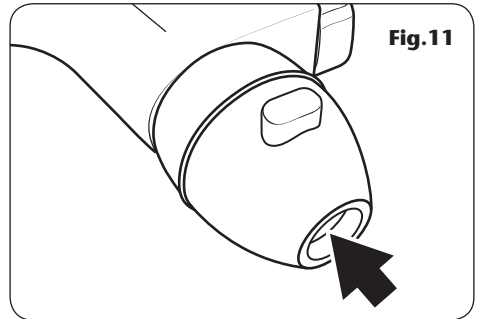

WARNING!

DO NOT use 'powerful' abrasive or solvent cleaning fluids when cleaning the shower as they may damage the plastic fittings.

CLEANING

DO NOT use abrasive or solvent cleaning fluids. The shower unit, riser rail, hose, etc. should be cleaned using a soft cloth and warm water.

IT IS IMPORTANT TO KEEP THE SHOWERHEAD CLEAN TO MAINTAIN THE PERFORMANCE OF THE SHOWER. The hardness of the water will determine the frequency of cleaning. For example, if the shower is used every day in a very hard water area, it may be necessary to clean the showerhead on a weekly basis.

SPARE PARTS

Ref.	Description	Part No.
1	Flow control knob	83307390
2	Temperature control knob	83307420
3	Mechanical headwork	83307320
4	Cartridge	83307410
5	Non-return valve	83307290
6	Ball grip	83307570
7	Outlet	83307540
8	Diverter/outlet connection	83307580
9	Pillar (pair)	83307550
10	Fixed showerhead holder	22010670
11	Flexible hose	28100010
Optional		
-	Bar valve bracket	UNBMBXBT

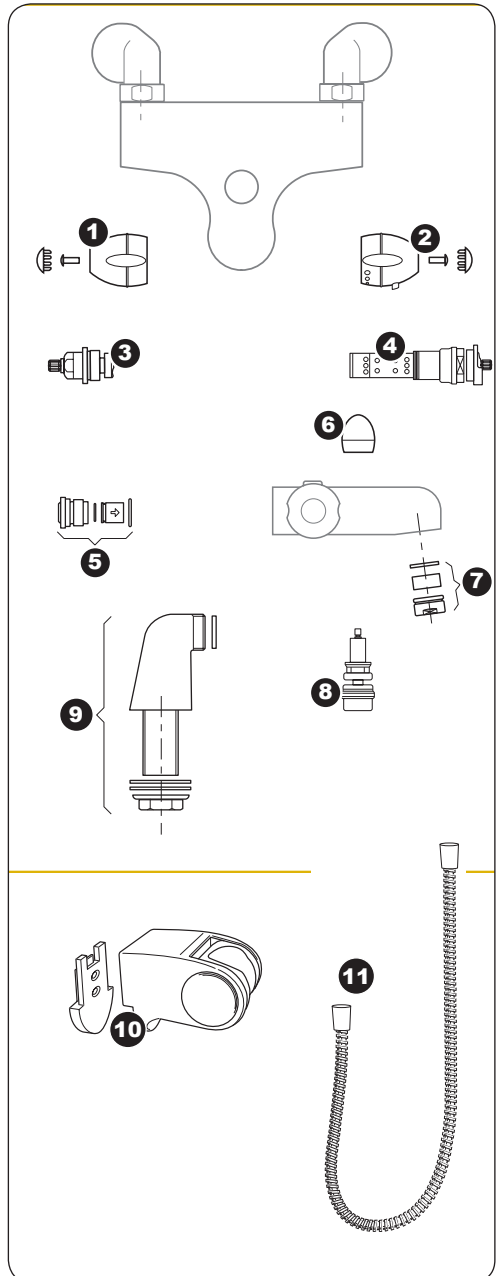

Bath shower mixer

FAULT FINDING

The following can be carried out by a competent person

<i>Problem/Symptom</i>	<i>Cause</i>	<i>Action/Cure</i>
1 Water too hot.	1.1 Temperature control incorrectly commissioned.	1.1.1 Refer to commissioning section.
	1.2 Not enough cold water flowing through shower.	1.2.1 Turn temperature control anti-clockwise.
	1.3 Increase in the ambient cold water temperature.	1.3.1 Turn temperature control anti-clockwise.
	1.4 Cold water supply blocked.	1.4.1 Turn off shower and consult a competent plumber or contact Triton Customer Service.
	1.5 High volume of cold water drawn off elsewhere.	1.5.1 Reduce the simultaneous demand from the supply.
2 Water too cold.	2.1 Temperature control incorrectly commissioned.	2.1.1 Refer to commissioning section.
	2.2 Not enough hot water flowing through shower.	2.2.1 Turn the temperature control clockwise.
	2.3 Decrease in the ambient cold water temperature.	2.3.1 Turn the temperature control clockwise.
	2.4 Insufficient hot water supplies from the heating system.	2.4.1 Make sure heating appliance is set to maximum or has sufficient stored hot water. 2.4.2 Make sure heating appliance is igniting by trying a hot water tap elsewhere.
	2.5 Hot water supply blocked or restricted.	2.5.1 Turn off shower and consult a competent plumber or contact Triton Customer Service.
	2.6 Flow limiter not fitted.	2.6.1 Fit the supplied flow limiter in the showerhead see 'instantaneous gas water heaters'.
3 High water flow and/or poor performance on a mains fed system.	3.1 Flow limiters not fitted.	3.1.1 Fit flow limiters in the mixer inlets.
4 Water does not flow or shower pattern collapses when another outlet is turned on.	4.1 Water supplies cut off.	4.1.1 Check water elsewhere in house and if necessary contact local water company.
	4.2 Shower unit blocked.	4.2.1 Inspect the inlet filters. Clean if necessary.
	4.3 Blockage in pipework.	4.3.1 Turn off the shower and consult a suitably competent plumber.
	4.4 Showerhead blocked.	4.4.1 Clean showerhead.

FAULT FINDING

The following is recommended for a professional qualified installer only

Problem/Symptom Cause

Action/Cure

	4.5 System not capable of supplying multiple outlets at the same time.	4.5.1 Reduce the simultaneous demand. 4.5.2 Make sure the stop/service valves are fully open. 4.5.3 Check if sufficient water pressure.
5 Water too cold.	5.1 Running pressure in excess of maximum recommended.	5.1.1 Fit a pressure reducing valve.
6 Shower controls noisy whilst in use.	6.1 Running pressure in excess of maximum recommended.	6.1.1 Fit a pressure reducing valve.
7 Shower will not shut off.	7.1 Flow control washer worn.	7.1.1 Renew flow control washer.



Service Policy

In the event of a complaint occurring, the following procedure should be followed:

- 1 Telephone Customer Service on 0870 067 3333 (0845 762 6591 in Scotland and in Northern Ireland), having available the model number and power rating of the product, together with the date of purchase.
- 2 Triton Customer Service will be able to confirm whether the fault can be rectified by either the provision of a replacement part or a site visit from a qualified Triton service engineer.
- 3 If a service call is required the unit must be fully installed for the call to be booked and the date confirmed. In order to speed up your request, please have your postcode available when booking a service call.
- 4 It is essential that you or an appointed representative (who must be a person of 18 years of age or more) is present during the service engineer's visit and receipt of purchase is shown.
- 5 A charge will be made in the event of an aborted service call by you but not by us, or where a call under the terms of guarantee has been booked and the failure is not product related (i.e. scaling and furring, incorrect water pressure).
- 6 If the product is no longer covered by the guarantee, a charge will be made for the site visit and for any parts supplied.
- 7 Service charges are based on the account being settled when work is complete, the engineer will then request payment for the invoice. If this is not made to the service engineer or settled within ten working days, an administration charge will be added.

Replacement Parts Policy

Availability: It is the policy of Triton to maintain availability of parts for the current range of products for supply after the guarantee has expired. Stocks of spare parts will be maintained for the duration of the product's manufacture and for a period of five years thereafter.

In the event of a spare part not being available a substitute part will be supplied.

Payment: The following payment methods can be used to obtain spare parts:

- 1 By post, pre-payment of pro forma invoice by cheque or money order.
- 2 By telephone, quoting credit card (MasterCard or Visa) details.
- 3 By website order, www.tritonshowers.co.uk

Triton Showers
Triton Road
Nuneaton
Warwickshire CV11 4NR

Triton is a division of Norcros Group (Holdings) Limited

TRITON STANDARD GUARANTEE

Triton guarantee this product against all mechanical defects arising from faulty workmanship or materials for a period of five years for domestic use only, from the date of purchase, provided that it has been installed by a competent person in full accordance with the fitting instructions.

Any part found to be defective during this guarantee period we undertake to repair or replace at our option without charge so long as it has been properly maintained and operated in accordance with the operating instructions, and has not been subject to misuse or damage.

This product must not be taken apart, modified or repaired except by a person authorised by Triton. This guarantee applies only to products installed within the United Kingdom and does not apply to products used commercially. This guarantee does not affect your statutory rights.

What is not covered:

- 1 Breakdown due to: *a)* use other than domestic use by you or your resident family; *b)* wilful act or neglect; *c)* any malfunction resulting from the incorrect use or quality of water or incorrect setting of controls; *d)* faulty installation.
- 2 Repair costs for damage caused by foreign objects or substances.
- 3 Total loss of the product due to non-availability of parts.
- 4 Compensation for loss of use of the product or consequential loss of any kind.
- 5 Call out charges where no fault has been found with the appliance.
- 6 The cost of repair or replacement of showerheads, hoses, riser rails and/or wall brackets or any other accessories installed at the same time.
- 7 The cost of routine maintenance, adjustments, overhaul modifications or loss or damage arising therefrom, including the cost of repairing damage, breakdown, malfunction caused by corrosion, furring, pipe scaling, limescale, system debris or frost.

Customer Service: ☎ 0870 067 3333

**Scottish and Northern Ireland
Customer Service:** ☎ 0845 762 6591

Trade Installer Hotline: ☎ 0870 067 3767
Fax: 0870 067 3334

www.tritonshowers.co.uk

E mail: technical@tritonshowers.co.uk