

Handle & plate design  
may vary depending on  
model chosen



**pioneer**  
tomorrow's technology today

# Pioneer Concealed Twin Control Thermostatic Shower Valve

## Installation & Operating Guide

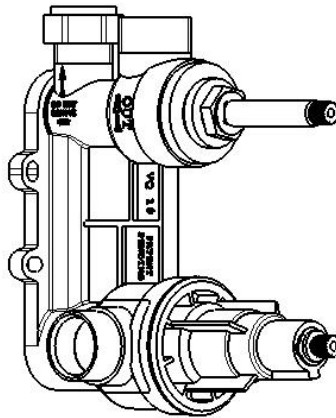

**Please leave this installation & user guide with the end user**



**NB: DO NOT USE COMPRESSION FITTINGS TO CONNECT TO THE VALVE  
PLEASE SEE THE PLUMBING CONNECTIONS SECTION BEFORE FITTING**

## CONTENTS

1.	Important information	1
2.	Cleaning & Aftercare	2
3.	Box contents	2-3
4.	Dimensions	3
5.	Plumbing Connections	4
6.	Installation	5-6
7.	Temperature adjustment	6-7
8.	Fault diagnosis	8
9.	Contact details	8

### WORLDWIDE PATENTS

Great Britain 2399159  
United States 6994266  
European 1463982  
China 1628275

# 1. IMPORTANT INFORMATION

- Thank you for purchasing this high quality Twin Control Concealed Thermostatic Shower Valve. To ensure you get the very best use from this product, please read this installation guide thoroughly.
- This shower valves has separate controls for temperature & water flow control, and has been designed for concealed wall installations. The product is suitable for use on all plumbing systems including gravity, pumped, fully modulating combination boilers and unvented systems.
- Please make sure that any auxiliary products (e.g. shower kits) are suitable for connection to this product. **NB: Do not use compression fittings to connect to the shower valve. Please see the Plumbing Connections section before fitting.**
- Debris in the pipe work can get into the cartridges. This is easily avoided by thoroughly flushing the pipe work **BEFORE** connecting the shower valve to the water supplies.
- This shower valve is suitable for use with all water supply systems up to a maximum dynamic water pressures of 5 bar (**balanced water pressures are desirable for best performance**). Pressures above this limit may require pressure reducing valves to be fit.
- This product must be installed in such a way that water damage is not caused during use. **We recommend that this product is fitted by a fully qualified installer. The installation must comply with all current water byelaws.**
- **NB. If you experience any difficulty with the installation or operation of your new shower valve, please refer to 'Fault Diagnosis' at the back of this guide.**

## 2. CLEANING & AFTER CARE

This product is made using high quality chrome plating, and this should be maintained using a clean damp cloth. No abrasive agents or materials should be used and **any misuse will invalidate your guarantee.**

This precision made thermostatic shower valve will continue to give years of use provided it has been installed & operated in accordance with these fitting instructions. Failure to do this will invalidate any guarantees.

The main body of this shower valve is 100% recyclable. Please make sure that at the end of the products operative life, it is disposed of in accordance with current local authority recycling guidelines.

## 3. BOX CONTENTS

Please note: Handles & plate may vary depending on the model supplied.

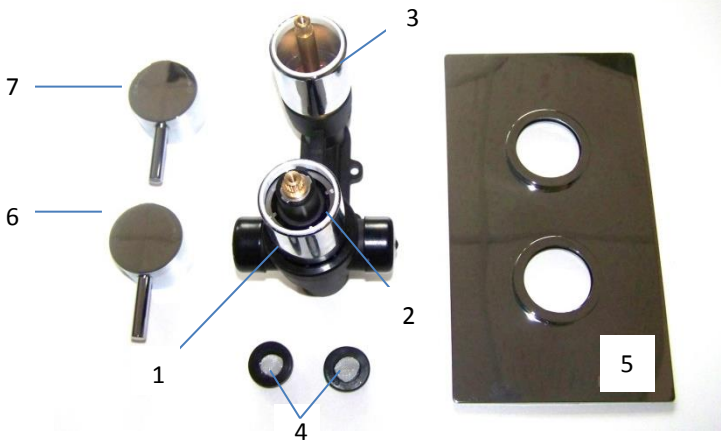

1. Main thermostatic shower valve body.
2. Chrome temperature control sleeve.
3. Chrome flow control sleeve.
4. Filter washers x 2 (for use with flat faced connectors).
5. Chrome concealing plate.
6. Chrome thermostatic control handle.
7. Chrome flow control handle.

Other things you will require which are not supplied include (this is not an exhaustive list):

Suitable wall fixings, isolating valves & non-return (check) valves, screwdrivers, an adjustable wrench, a bucket (for flushing out pipework), a thermometer, silicone, a spirit level and 3 No.  $\frac{3}{4}$ " BSP flat faced connectors.

#### 4. DIMENSIONS

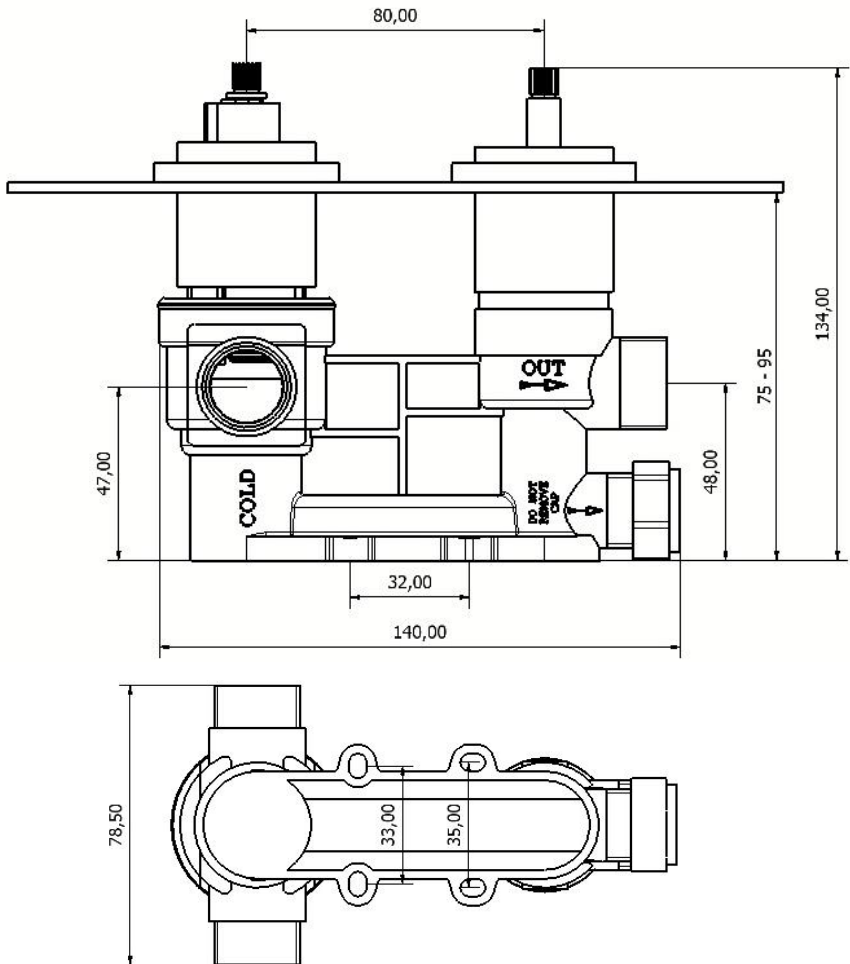

## 5. PLUMBING CONNECTIONS

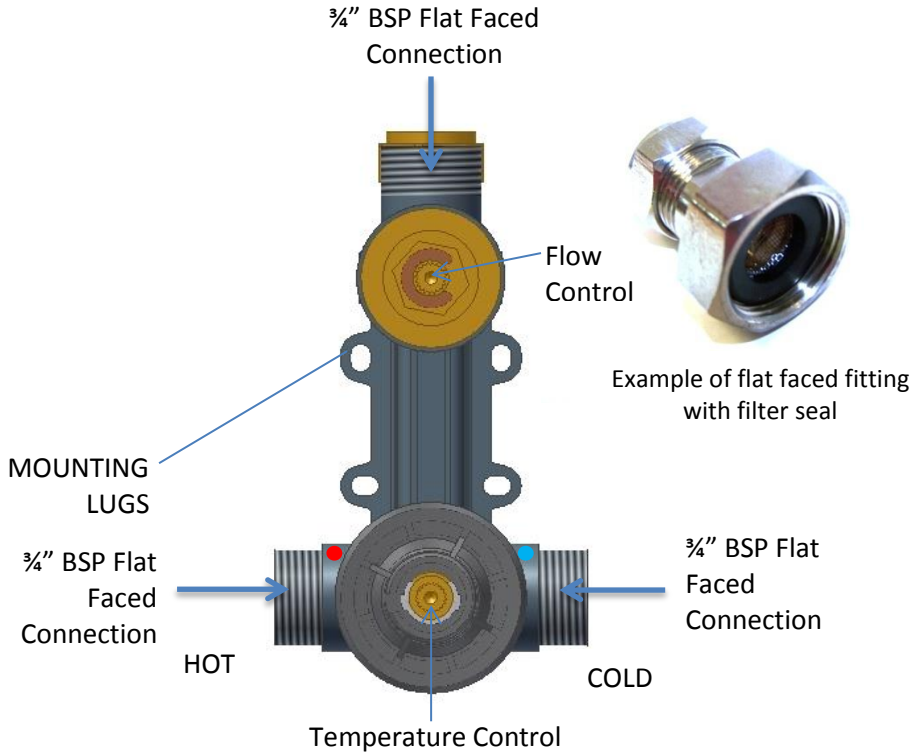

**DO NOT UNDER ANY CIRCUMSTANCES USE COMPRESSION FITTINGS TO CONNECT TO THE INLETS & OUTLET OF THIS VALVE. THE INLETS & OUTLET ARE FLAT FACED CONNECTIONS AND ARE NOT DESIGNED TO TAKE COMPRESSION FITTINGS**

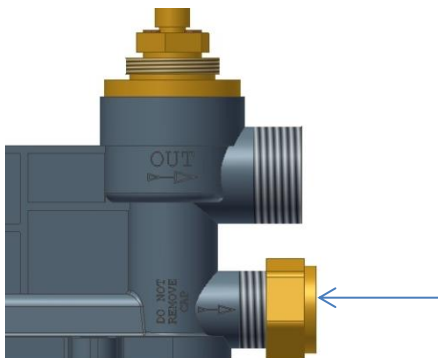

**DO NOT REMOVE**  
This cap is glued in place and should never be removed

## 6. INSTALLATION INSTRUCTIONS

1. Remove the chrome sleeves from the shower valve body, and leave to one side in a safe place.
2. Isolation valves must be fit on the HOT & COLD water supply lines for servicing purposes. Please fit these in an easily accessible place so that the water can be isolated for servicing.
3. Please fit non return valves (check valves) to the HOT & COLD inlet pipework also. These are not supplied.
4. A recess is required to fit the valve into. The cover plate should be able to cover the recess. **The recess should have a flat area at the bottom to mount the valve onto.** The recess depth will depend on the handle and plate set supplied and how far the handles are to extrude from the wall. Please see the Dimensions Section.
5. Using cap-head type screws, screw through the holes in the mounting lugs and secure the valve to the flat surface. Do not over tighten the screws.
6. Please make sure the valve body is mounted to the correct depth from the finished wall surface. When the cover plate is off there should be enough room to access the valve for servicing.
7. **Before the pipework is connected to the valve, make sure the pipework is thoroughly flushed through to remove any debris from the system. Failure to do so could invalidate the guarantee.**
8. Now that the valve is in place, please connect the valve to the pipework. The pipework should be connected to the valve using  $\frac{3}{4}$ " flat faced connections (see Plumbing Connections Section). **DO NOT ATTEMPT TO FIT COMPRESSION FITTINGS ON TO THE INLETS OF THE VALVE. THE INLETS ARE NOT DESIGNED TO TAKE COMPRESSION FITTINGS.** The hot and cold sides are clearly marked.
9. You can now connect the outlet to the pipework using a  $\frac{3}{4}$ " flat faced connector. **DO NOT ATTEMPT TO FIT A COMPRESSION FITTING ON TO THE OUTLET OF THE VALVE. THE OUTLET IS NOT DESIGNED TO TAKE COMPRESSION FITTINGS.**

10. Turn on the water supply and check for leaks.
11. Check the max water temperature from the terminal fitting with a thermometer. The recommended maximum terminal outlet temperature is 41°C. If the water temperature is not suitable please see the Temperature Adjustment Section.
12. Re fit the chrome sleeves to the shower body.
13. Apply a small bead of silicone behind the chrome concealing plate (this will give a water tight seal so water cannot ingress into the wall cavity). Slide the plate into position over the chrome sleeves, and fit up against the finished wall surface.
14. Fit the chrome control handles. The thermostatic control handle is clearly marked with H & C.
15. Your shower valve is now ready for use.

## 7. TEMPERATURE ADJUSTMENT

1. Remove the handle on the thermostat control. The removal method will differ depending on the handle type. The spline or Brass Stop Ring will now be exposed.
2. If there is a Brass Stop Ring present please remove it. Then turn the shower flow control fully on.
3. If the shower is too cold then turn the spline anti-clockwise. If the handle is too hot then turn the spline clockwise. Let the water temperature stabilise after every adjustment. We recommend a max temperature of 41°C. **The mixed water temperature at the terminal fitting must never exceed 46°C.**
4. When the temperature is correct, turn the flow control off. Do not move the spline again until after the handle is secured in place. The max temperature is now set and any movement of the spline will alter the temperature.



- Depending on your handle type the temperature will be limited by a handle with an in built stop lug or by a separate Brass Stop Ring. Please see the diagrams below.

The handle can now be put back in place. **When the Handle/Brass Stop Ring is being placed over the spline, please ensure that the Stop Lug is against the cartridge Stop Lug preventing the handle from being turned any further anti clockwise. This prevents the shower valve from reaching a temperature that is higher than the set point.**

- The handle can now be fixed in place. The shower should have a safe maximum showering temperature.

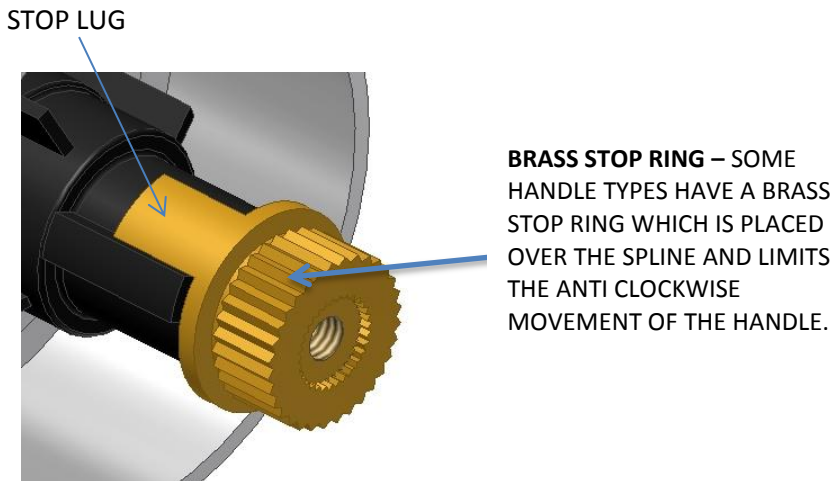
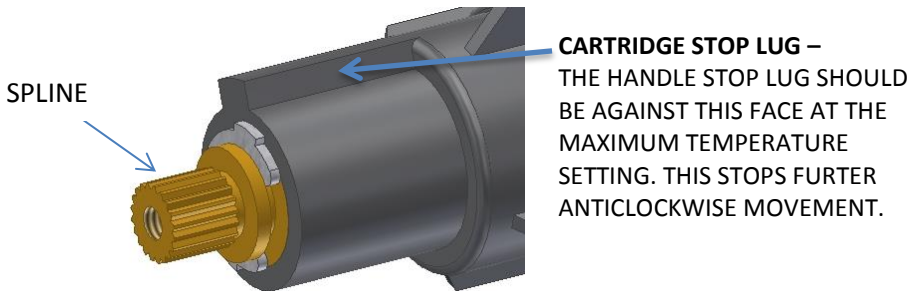

## 8. FAULT DIAGNOSIS

FAULT	POSSIBLE CAUSE
After installation, shower only runs HOT or COLD.	1. Hot and cold water supplies are plumbed to the wrong sides of the valve. The valve body needs to be plumbed so that the hot supply goes to the hot side of the valve.
Shower will not run hot enough when first installed.	1. Check Hot Water supply temperature. 2. Maximum temperature needs adjusting. See Temperature Adjustment section above. 3. Operating Conditions are incorrect. 4. Blockage in hot side of the system.
Hot water in cold & vice versa	1. Make sure serviceable in line check valves have been fitted. Check & clean them if they are already installed.
Low or no flow from the Valve	1. Possible blockage in the system. 2. Operating Conditions are incorrect. 3. Valve being obstructed by debris. 4. Valve shut off has activated due to Operating Conditions.
Leak from valve in the off position	1. Debris has gotten into the CD valve.
Fluctuating Flow Rate	1. Possible blockage in the system. 2. Operating conditions are incorrect. 3. Dynamic inlet pressures are not balanced. 4. Shuttle assembly is faulty.

## 9. CONTACT DETAILS

Please do not contact Customer Care until the Fault Diagnosis Chart has been consulted. Please ensure the valve has been installed within the recommended operating conditions. If you still require assistance please contact customer care using the details below:



Ultra Finishing Ltd,  
Hamnett House,  
Gibbet Street,  
Halifax, Yorkshire,  
HX2 0AX.

Customer Care Tel: 01422 417110

